

THIS FILE IS MADE AVAILABLE THROUGH THE DECLASSIFICATION EFFORTS AND RESEARCH OF:

THE BLACK VAULT

THE BLACK VAULT IS THE LARGEST ONLINE FREEDOM OF INFORMATION ACT / GOVERNMENT RECORD CLEARING HOUSE IN THE WORLD. THE RESEARCH EFFORTS HERE ARE RESPONSIBLE FOR THE DECLASSIFICATION OF THOUSANDS OF DOCUMENTS THROUGHOUT THE U.S. GOVERNMENT, AND ALL CAN BE DOWNLOADED BY VISITING:

[HTTP://WWW.BLACKVAULT.COM](http://www.blackvault.com)

YOU ARE ENCOURAGED TO FORWARD THIS DOCUMENT TO YOUR FRIENDS, BUT PLEASE KEEP THIS IDENTIFYING IMAGE AT THE TOP OF THE .PDF SO OTHERS CAN DOWNLOAD MORE!

National Aeronautics and
Space Administration

Lyndon B. Johnson Space Center

2101 NASA Road 1
Houston, Texas 77058-3696



Reply to Attn of:

AP4-FOIA-98-185

June 10, 1998

Mr. John Greenwald, Jr.

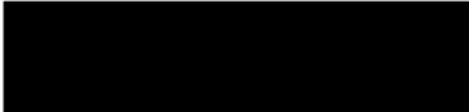

Dear Mr. Greenwald:

This is in response to your Freedom of Information Act (FOIA) request, dated May 21, 1998, and received May 26, 1998, for a copy of the Apollo 13 CSM.

The requested information is enclosed.

Per NASA Regulations [14 CFR Sec. 1206.700 (I)(2)], the fee for the enclosed information is waived as the cost is less than \$5.

Sincerely,

A handwritten signature in cursive script that reads "Stella Luna".

**Stella Luna
FOIA Coordinator
Community Affairs Branch
Office of Public Affairs**

Enclosures

"CASE FILE COPY" 775

MSC-02680

(MICROFICHE)

T 70-00438 2.1



NATIONAL AERONAUTICS AND SPACE ADMINISTRATION

(N 71-13073)

APOLLO 13 MISSION REPORT

TECHNICAL LIBRARY
BUILDING 45

OCT 6 1970

Manned Spacecraft Center
Houston, Texas 77058

AVAILABLE TO NASA AND
NASA CONTRACTORS ONLY

DISTRIBUTION AND REFERENCING

This paper is not suitable for general distribution or referencing. It may be referenced only in other working correspondence and documents by participating organizations.



MANNED SPACECRAFT CENTER

HOUSTON, TEXAS

SEPTEMBER 1970

APOLLO SPACECRAFT FLIGHT HISTORY

<u>Mission</u>	<u>Spacecraft</u>	<u>Description</u>	<u>Launch date</u>	<u>Launch site</u>
PA-1	BP-6	First pad abort	Nov. 7, 1963	White Sands Missile Range, N. Mex.
A-001	BP-12	Transonic abort	May 13, 1964	White Sands Missile Range, N. Mex.
AS-101	BP-13	Nominal launch and exit environment	May 26, 1964	Cape Kennedy, Fla.
AS-102	BP-15	Nominal launch and exit environment	Sept. 18, 1964	Cape Kennedy, Fla.
A-002	BP-23	Maximum dynamic pressure abort	Dec. 8, 1964	White Sands Missile Range, N. Mex.
AS-103	BP-16	Micrometeoroid experiment	Feb. 16, 1965	Cape Kennedy, Fla.
A-003	BP-22	Low-altitude abort (planned high- altitude abort)	May 19, 1965	White Sands Missile Range, N. Mex.
AS-104	BP-26	Micrometeoroid experiment and service module RCS launch environment	May 25, 1965	Cape Kennedy, Fla.
PA-2	BP-23A	Second pad abort	June 29, 1965	White Sands Missile Range, N. Mex.
AS-105	BP-9A	Micrometeoroid experiment and service module RCS launch environment	July 30, 1965	Cape Kennedy, Fla.
A-004	SC-002	Power-on tumbling boundary abort	Jan. 20, 1966	White Sands Missile Range, N. Mex.
AS-201	SC-009	Supercircular entry with high heat rate	Feb. 26, 1966	Cape Kennedy, Fla.
AS-202	SC-011	Supercircular entry with high heat load	Aug. 25, 1966	Cape Kennedy, Fla.

(Continued inside back cover)

CHANGE SHEET
FOR
NASA-MSC INTERNAL REPORT
APOLLO 13 MISSION REPORT

*c. 1
Callahan
7-27-71*

Change 1

May 1970

James A. McDivitt

James A. McDivitt
Colonel, USAF
Manager, Apollo Spacecraft Program

Page 1 of 13 pages
(with enclosures)

After the attached enclosures (pages 7-3, 7-4, 7-7, 7-8, 11-3 through 11-6, E-3, E-4, and back cover), which are replacement pages, have been inserted, insert this CHANGE SHEET between the cover and title page and write on the cover "Change 1 inserted."

In addition to the attached changes, please complete the attached Mission Report Questionnaire and return as indicated.

NOTE: A black bar in the margin of affected pages indicates the information that was changed or added.

Signature of person incorporating changes

Date

APOLLO 13 MISSION REPORT

PREPARED BY

Mission Evaluation Team

APPROVED BY

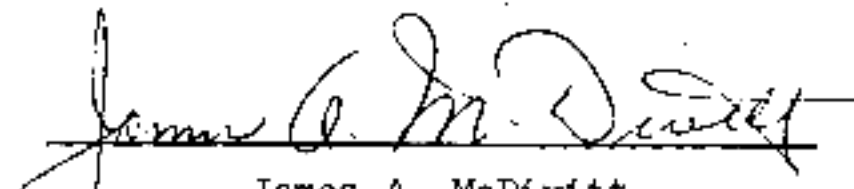

James A. McDivitt
Colonel, USAF
Manager, Apollo Spacecraft Program

NATIONAL AERONAUTICS AND SPACE ADMINISTRATION

MANNED SPACECRAFT CENTER

HOUSTON, TEXAS

September 1970



Apollo 13 lift-off.

TABLE OF CONTENTS

Section		Page
1.0	<u>SUMMARY</u>	1-1
2.0	<u>INTRODUCTION</u>	2-1
3.0	<u>MISSION DESCRIPTION</u>	3-1
4.0	<u>TRAJECTORY</u>	4-1
5.0	<u>COMMAND AND SERVICE MODULE PERFORMANCE</u>	5-1
	5.1 STRUCTURAL AND MECHANICAL SYSTEMS	5-1
	5.2 ELECTRICAL POWER	5-2
	5.3 CRYOGENIC STORAGE	5-3
	5.4 COMMUNICATIONS EQUIPMENT	5-4
	5.5 INSTRUMENTATION	5-4
	5.6 GUIDANCE, NAVIGATION, AND CONTROL	5-5
	5.7 REACTION CONTROL	5-11
	5.8 ENVIRONMENTAL CONTROL	5-12
6.0	<u>LUNAR MODULE PERFORMANCE</u>	6-1
	6.1 STRUCTURAL	6-1
	6.2 ELECTRICAL POWER	6-1
	6.3 COMMUNICATIONS EQUIPMENT	6-2
	6.4 GUIDANCE, NAVIGATION, AND CONTROL	6-2
	6.5 REACTION CONTROL	6-8
	6.6 DESCENT PROPULSION	6-8
	6.7 ENVIRONMENTAL CONTROL	6-9
7.0	<u>MISSION CONSUMABLES</u>	7-1
	7.1 COMMAND AND SERVICE MODULES	7-1
	7.2 LUNAR MODULE	7-4
8.0	<u>PILOTS' REPORT</u>	8-1
	8.1 TRAINING	8-1
	8.2 PRELAUNCH PREPARATION	8-1
	8.3 LAUNCH	8-2
	8.4 EARTH ORBIT	8-2

Section	Page
8.5	TRANSLUNAR INJECTION 8-2
8.6	TRANSPOSITION AND DOCKING 8-7
8.7	TRANSLUNAR FLIGHT 8-7
8.8	TRANSEARTH INJECTION 8-11
8.9	TRANSEARTH COAST 8-11
8.10	ENTRY AND LANDING 8-17
9.0	<u>BIOMEDICAL EVALUATION</u> 9-1
9.1	BIOINSTRUMENTATION AND PHYSIOLOGICAL DATA . . . 9-1
9.2	INFLIGHT HISTORY 9-2
9.3	PHYSICAL EXAMINATIONS 9-6
10.0	<u>MISSION SUPPORT PERFORMANCE</u> 10-1
10.1	FLIGHT CONTROL 10-1
10.2	NETWORK 10-2
10.3	RECOVERY OPERATIONS 10-2
11.0	<u>EXPERIMENTS</u> 11-1
11.1	ATMOSPHERIC ELECTRICAL PHENOMENA 11-1
11.2	EARTH PHOTOGRAPHY APPLIED TO GEOSYNCHRONOUS SATELLITES 11-8
11.3	SEISMIC DETECTION OF THIRD STAGE LUNAR IMPACT . 11-9
12.0	<u>ASSESSMENT OF MISSION OBJECTIVES</u> 12-1
13.0	<u>LAUNCH VEHICLE SUMMARY</u> 13-1
14.0	<u>ANOMALY SUMMARY</u> 14-1
14.1	COMMAND AND SERVICE MODULES 14-1
14.2	LUNAR MODULE 14-24
14.3	GOVERNMENT FURNISHED EQUIPMENT 14-36
15.0	<u>CONCLUSIONS</u> 15-1
APPENDIX A	<u>- VEHICLE DESCRIPTIONS</u> A-1
A.1	COMMAND AND SERVICE MODULES A-1
A.2	LUNAR MODULE A-1
A.3	EXPERIMENT EQUIPMENT A-2
A.4	LAUNCH VEHICLE A-5
A.5	MASS PROPERTIES A-5

Section	Page
APPENDIX B - <u>SPACECRAFT HISTORIES</u>	B-1
APPENDIX C - <u>POSTFLIGHT TESTING</u>	C-1
APPENDIX D - <u>DATA AVAILABILITY</u>	D-1
APPENDIX E - <u>MISSION REPORT SUPPLEMENTS</u>	E-1
REFERENCES	R-1

1.0 SUMMARY

The Apollo 13 mission, planned as a lunar landing in the Fra Mauro area, was aborted because of an abrupt loss of service module cryogenic oxygen associated with a fire in one of the two tanks at approximately 56 hours. The lunar module provided the necessary support to sustain a minimum operational condition for a safe return to earth. A circumlunar profile was executed as the most efficient means of earth return, with the lunar module providing power and life support until transfer to the command module just prior to entry. Although the mission was unsuccessful as planned, a lunar flyby and several scientific experiments were completed.

The space vehicle, with a crew of James A. Lovell, Commander; Fred W. Haise, Jr., Lunar Module Pilot; and John L. Swigert, Jr., Command Module Pilot; was launched from Kennedy Space Center, Florida, at 2:13:00 p.m. e.s.t. (19:13:00 G.m.t.) April 11, 1970. Two days before launch, the Command Module Pilot, as a member of the Apollo 13 backup crew, was substituted for his prime crew counterpart, who was exposed and found susceptible to rubella (German measles). Prior to launch, a network of meters was installed in the vicinity of the launch site to measure electrical phenomena associated with Saturn V ascent in support of findings from the Apollo 12 lightning investigation; satisfactory data were obtained. During S-II stage boost, an automatic shutdown of the center engine occurred because of a divergent dynamic structural condition associated with that engine. Soon after the spacecraft was ejected, the S-IVB was maneuvered so as to impact on the lunar surface and provide seismological data. Following this maneuver, a series of earth photographs were taken for later use in determining wind profiles in the upper atmosphere. The first midcourse correction inserted the spacecraft into a non-free-return trajectory.

At approximately 56 hours, the pressure in cryogenic oxygen tank 2 began to rise at an abnormally high rate and, within about 100 seconds, the tank abruptly lost pressure. The pressure in tank 1 also dropped but at a rate sufficient to maintain fuel cell 2 in operation for approximately 2 more hours. The loss of oxygen and primary power in the service module required an immediate abort of the mission. The crew powered up the lunar module, and the first maneuver following the incident was made with the descent propulsion system to place the spacecraft once again on a free-return trajectory. A second maneuver performed with the descent engine 2 hours after passing pericynthion reduced the transearth transit time and moved the earth landing point from the Indian Ocean to the South Pacific. Two small transearth midcourse corrections were required prior to entry.

The lunar module was jettisoned 1 hour before entry, which was performed nominally using the primary guidance and navigation system. Landing occurred at 142:54:41 within sight of the recovery ship. The landing point was reported as 21 degrees 38 minutes 24 seconds south latitude and 165 degrees 21 minutes 42 seconds west longitude. The crew were retrieved and aboard the recovery ship within 45 minutes after landing.

2.0 INTRODUCTION

Apollo 13 was the thirteenth in a series of missions using Apollo specification flight hardware and was to be the third lunar landing. The primary mission objective was a precise lunar landing to conduct scientific exploration of deep-rooted surface material.

Because an inflight anomaly in the cryogenic oxygen supply required an abort of the mission prior to insertion into lunar orbit, discussions of systems performance only relate to the abort profile and the system configurations required as a result of the emergency. A complete discussion of the anomaly is presented in reference 1, and the abort profile is described in section 3. Because of the added criticality of onboard consumables, a discussion of usage profiles in both vehicles is contained in section 7.

A complete analysis of all flight data is not possible within the time allotted for preparation of this report. Therefore, report supplements will be published for certain Apollo 13 systems analyses, as shown in appendix E. This appendix also lists the current status of all Apollo mission supplements, either published or in preparation. Other supplements will be published as the need is identified.

In this report, all actual times prior to earth landing are elapsed time from range zero, established as the integral second before lift-off. Range zero for this mission was 19:13:00 G.m.t., April 11, 1970. All references to mileage distance are in nautical miles.

3.0 MISSION DESCRIPTION

The Apollo 13 mission was planned as a precision lunar landing in the Fra Mauro highlands. The most significant changes to the planned mission profile from Apollo 12 were the maneuver to impact the depleted S-IVB stage on the lunar surface and the performance of descent orbit insertion using the service propulsion system. The S-IVB impact was intended to provide seismological data sensed by the instrument left on the moon during Apollo 12. Performance of the descent orbit insertion using the service propulsion system provides a greater propellant margin in the lunar module descent propulsion system, and this reserve would have been available during the critical precision landing phase.

Because of a sudden loss of pressure at approximately 56 hours from one of the two service module cryogenic oxygen tanks in bay 4, primary electrical power was lost and the mission was aborted. Therefore, the remainder of this section will consider only the abort profile, since the trajectory prior to the tank incident was nearly identical to that of Apollo 12, including the first midcourse maneuver to a non-free-return profile, as shown in figure 3-1. The major trajectory difference from Apollo 12 resulted from an early shutdown of the center engine in the S-II stage of the Saturn V, the subsequent staging and insertion times were somewhat later than planned. A listing of significant mission events is contained in table 3-I.

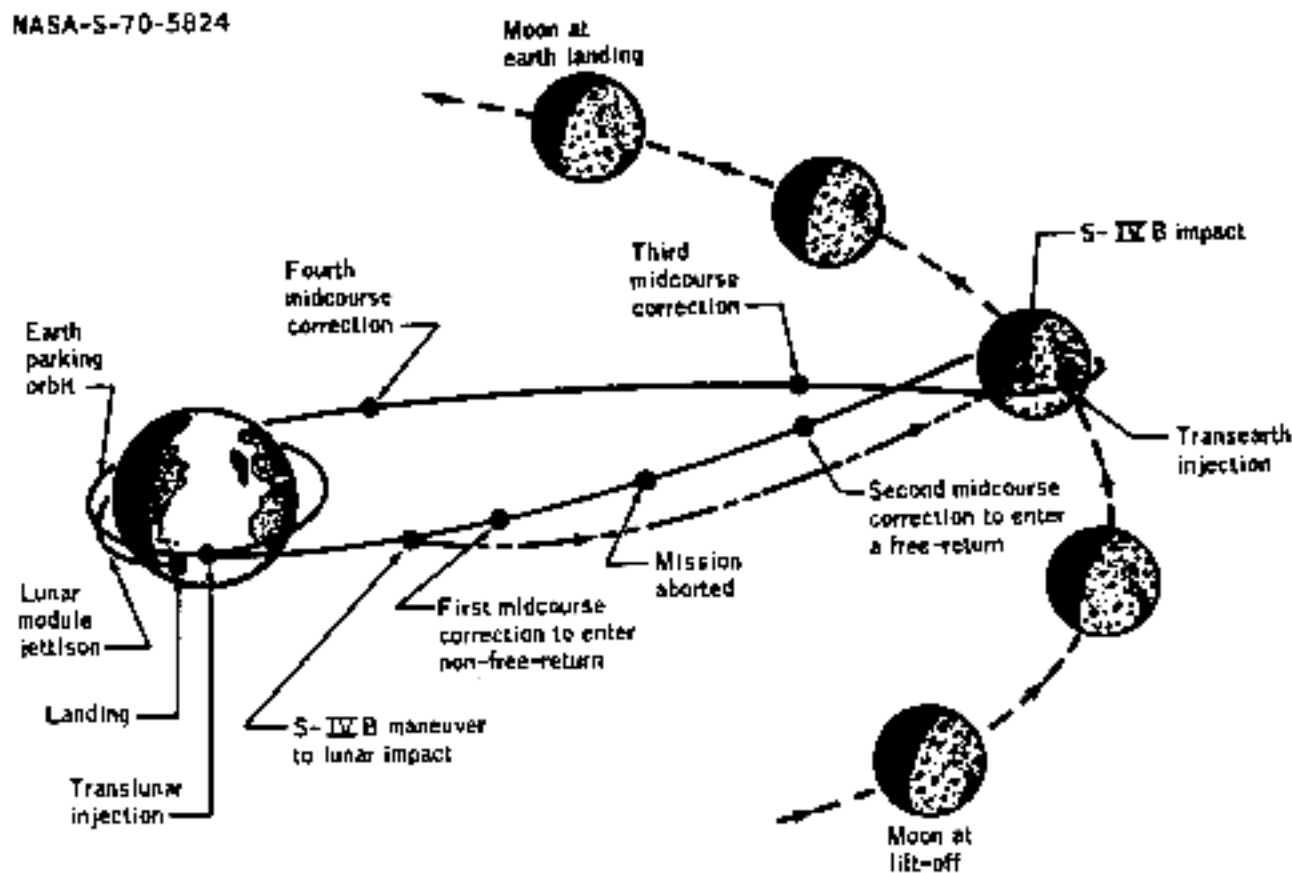

Figure 3-1.- Apollo 13 mission profile.

TABLE 3-1.- SEQUENCE OF EVENTS

Event	Time, hr:min:sec
Range zero - 19:13:00:00 G.m.t., April 11, 1970	
Lift-off - 19:13:00.65 G.m.t., April 11, 1970	
S-IC outboard engine cutoff	00:02:44
S-II engine ignition (command time)	00:02:45
Launch escape tower jettison	00:03:21
S-II engine cutoff	00:09:53
S-IVB engine ignition (command time)	00:09:54
S-IVB engine cutoff	00:12:30
Translunar injection maneuver	02:35:46
S-IVB/command and service module separation	03:06:39
Docking	03:19:09
Spacecraft ejection	04:01:01
S-IVB separation maneuver	04:18:01
First midcourse correction (service propulsion)	30:40:50
Cryogenic oxygen tank incident	55:54:53
Second midcourse correction (descent propulsion)	61:29:43
S-IVB lunar impact	77:56:40
Transearth injection (descent propulsion)	79:27:39
Third midcourse correction (descent propulsion)	105:18:28
Fourth midcourse correction (IM reaction control)	137:39:52
Command module/service module separation	138:01:48
Undocking	141:30:00
Entry interface	142:40:46
Landing	142:54:41

After powering up the lunar module, co-aligning the two platforms, and shutting down all command and service module systems following the tank anomaly, a maneuver was immediately performed to return the spacecraft to a free-return profile. The maneuver was performed as the second midcourse correction, using the descent propulsion system in the docked configuration, a mode tested successfully during Apollo 9. The resultant landing at earth would have been at 152 hours in the Indian Ocean, with lunar module systems intended to support the crew for the remaining 90 hours. Because consumables were extremely marginal in this emergency mode and because only minimal recovery support existed at this earth landing location, a transearth injection maneuver using the descent propulsion system was planned for execution 2 hours after passing pericynthion. Between these two maneuvers, an alignment check was made of the lunar module inertial platform to verify the maneuver would be executed with sufficient accuracy to permit a safe earth entry.

The transearth injection maneuver was performed on time, and the transearth coast time was shortened such that landing was to occur at about 143 hours in the South Pacific, where primary recovery support was located. Guidance errors during this maneuver necessitated a small midcourse correction at about 105 hours to return the projected entry flight path angle to within specified limits. Following this firing, the spacecraft was maneuvered into a passive thermal control mode, and all lunar module systems were powered down except those absolutely required to support the crew. A final midcourse correction was performed 5 hours before entry to raise the entry flight-path angle slightly, and this maneuver was performed using the lunar module reaction control system under abort guidance control.

The service module was separated 4-3/4 hours before entry, affording the crew an opportunity to observe and photograph the damaged bay 4 area. The command module was separated from the service module by using the lunar module reaction control system. The lunar module was retained for as long as possible to provide maximum electrical power in the command module for entry.

The command module was powered up with the three entry batteries, which had been brought up to nearly full charge using lunar module power. The command module platform was aligned to the lunar module platform, and the spacecraft were undocked 70 minutes before entry. After undocking, the escaping tunnel pressure provided the necessary separation velocity between the two spacecraft. From this point, the mission was completed nominally, as in previous flights, with the spacecraft landing approximately 1 mile from the target point. The lunar module, including the radioisotope thermoelectric fuel capsule used to power experiment equipment, entered the atmosphere and impacted in the open sea between Samoa

and New Zealand at 25.5 degrees south latitude and 176 degrees west longitude, with surveillance aircraft in the area. The three crewmen were onboard the recovery ship, USS Iwo Jima, within 45 minutes of landing, the fastest recovery time for all Apollo manned flights. A narrative discussion of the flight and associated crew activities is presented in section 8.0 as a complementary description to this section.

4.0 TRAJECTORY

The planned trajectory profile was similar to that for Apollo 12 except for descent orbit insertion being performed with the service propulsion system and the targeting of the spent S-IVB stage for a lunar impact. The trajectory had been very close to the nominal flight plan up to the time of abort, which was the first in the Apollo program. Throughout the manned space program, techniques have been developed and tested for the real-time determination of immediate abort requirements, but Apollo 13 presented the first situation in which their use was necessary. Figure 3-1 shows the mission profile, including the relative locations of all major maneuvers.

The analysis of the trajectory from lift-off to spacecraft/S-IVB separation was based on launch vehicle onboard data, as reported in reference 2, and from network tracking data. After separation, the actual trajectory information was determined from the best estimated trajectory generated from tracking and telemetry data. The earth and moon models used for the trajectory analysis are geometrically similar to those used for Apollo 12. Table 3-I is a listing of major flight events, and table 4-I defines the trajectory and maneuver parameters listed in table 4-II.

The planned launch and earth parking orbit phases for this mission were very similar to those for Apollo 12. However, during the second stage (S-II) boost into the planned 100-mile circular parking orbit, the center engine cut off about 132 seconds early and caused the remaining four engines to burn approximately 34 seconds longer than predicted (as discussed in section 13.0 and reference 2). Space vehicle velocity after S-II boost was 223 ft/sec lower than planned, and as a result, the S-IVB orbital insertion maneuver was approximately 9 seconds longer than predicted, with cutoff velocity within about 1.2 ft/sec of the planned value. The total time to orbital insertion was about 44 seconds longer than predicted, with actual parking orbit parameters of 100.2 by 98.0 miles.

As on Apollo 12, the S-IVB was targeted for a high-pericyynthion free-return translunar profile, with the first major spacecraft maneuver intended to lower the pericyynthion to the planned orbital altitude of 60 miles. Upon execution of this maneuver, the spacecraft was intentionally placed on a non-free-return trajectory. The achieved pericyynthion altitude at translunar injection was 415.8 miles. The accuracy of the translunar injection maneuver was such that the option for the first planned midcourse correction was not exercised. The velocity change required at the second planned midcourse option point, intended as the time for entering the non-free-return profile, was 23.2 ft/sec. The trajectory parameters for the translunar injection and all spacecraft maneuvers are presented in table 4-II.

TABLE 4-I.- DEFINITION OF TRAJECTORY AND ORBITAL PARAMETERS

<u>Trajectory Parameters</u>	<u>Definition</u>
Geodetic latitude	Spacecraft position measured north or south from the earth's equator to the local vertical vector, deg
Selenographic latitude	Spacecraft position measured north or south from the true lunar equatorial plane to the local vertical vector, deg
Longitude	Spacecraft position measured east or west from the body's prime meridian to the local vertical vector, deg
Altitude	Perpendicular distance from the reference body to the point of orbit intersect, feet or miles; altitude above the lunar surface is referenced to the altitude of the landing site with respect to mean lunar radius
Space-fixed velocity	Magnitude of the inertial velocity vector referenced to the body-centered, inertial reference coordinate system, ft/sec
Space-fixed flight-path angle	Flight-path angle measured positive upward from the body-centered, local horizontal plane to the inertial velocity vector, deg
Space-fixed heading angle	Angle of the projection of the inertial velocity vector onto the local body-centered, horizontal plane, measured positive eastward from north, deg
Apogee	Maximum altitude above the oblate earth model, miles
Perigee	Minimum altitude above the oblate earth model, miles
Apocynthion	Maximum altitude above the moon model, referenced to landing site altitude, miles
Pericynthion	Minimum altitude above the moon model, referenced to landing site altitude, miles
Period	Time required for spacecraft to complete 360 degrees of orbit rotation, min
Inclination	Acute angle formed at the intersection of the orbit plane and the reference body's equatorial plane, deg
Longitude of the ascending node	Longitude where the orbit plane crosses the reference body's equatorial plane from below, deg

TABLE 4-II.- TRAJECTORY PARAMETERS

Translunar phase								
Event	Reference body	Time, hr:min:sec	Latitude, deg	Longitude, deg	Altitude above launch pad, miles	Space-fixed velocity, ft/sec	Space-fixed flight-path angle, deg	Space-fixed heading angle, deg E of N
S-IVB second ignition	Earth	2:35:26.4	22.48S	142.45E	105.39	25 573.1	.032	65.708
S-IVB second cutoff	Earth	2:41:37.7	9.39S	156.45E	175.71	35 552.6	7.182	59.443
Translunar injection	Earth	2:41:47.2	8.92S	167.23E	182.45	35 538.4	7.635	59.308
Command and service module/S-IVB separation	Earth	3:06:38.9	27.03N	129.67W	3 778.54	25 027.8	45.034	72.297
Docking	Earth	3:19:08.8	30.21N	118.10W	5 994.90	21 381.4	51.507	79.351
Spacecraft/S-IVB separation	Earth	4:01:00.8	31.95N	105.30W	12 455.83	16 619.0	62.092	91.491
First midcourse correction Ignition	Earth	30:40:49.6	22.93N	101.85W	121 381.93	4 652.5	77.464	112.843
First midcourse correction Cutoff	Earth	30:40:53.1	22.80N	101.86W	121 385.43	4 655.6	77.743	112.751
Second midcourse correction Ignition	Earth	61:29:43.5	20.85N	159.70E	188 371.38	2 065.8	79.364	115.464
Second midcourse correction Cutoff	Earth	61:30:17.7	20.74N	159.56E	188 393.19	2 093.2	79.934	116.54
Transearth phase								
Transearth injection Ignition	Moon	79:27:39.0	3.73N	65.46E	5 465.26	4 547.7	72.645	-116.308
Transearth injection Cutoff	Moon	79:32:02.8	3.62N	64.77E	5 658.68	5 020.2	54.784	-117.886
Third midcourse correction Ignition	Earth	105:18:28.0	19.63N	136.84W	152 224.32	2 457.5	-79.671	114.134
Third midcourse correction Cutoff	Earth	105:18:42.0	19.50N	136.90W	152 215.57	2 456.5	-79.765	114.242
Fourth midcourse correction Ignition	Earth	137:39:51.5	11.35N	113.39E	37 808.55	10 109.1	-72.369	112.663
Fourth midcourse correction Cutoff	Earth	137:40:13.0	11.34N	113.32E	37 776.05	10 114.6	-72.373	112.660
Service module separation	Earth	138:01:48.0	10.88N	108.77E	35 694.93	10 405.9	-71.947	118.824
Undocking	Earth	141:30:00.2	1.23S	77.55E	11 257.48	17 465.9	-60.548	120.621
Entry interface	Earth	142:40:45.7	28.23S	173.44E	65.85	30 210.6	-6.269	77.210

The discarded S-IVB stage was targeted for a lunar impact of 3 degrees south latitude and 30 degrees west longitude. The S-IVB maneuver to achieve lunar impact was initiated at 6 hours, with a firing duration of 217 seconds using the auxiliary propulsion system. At approximately 19 hours 17 minutes, tracking data indicated the S-IVB had acquired an unexplained velocity increase of about 5 ft/sec along a projected earth radius which altered the projected lunar impact point closer to the target. The stage impacted the lunar surface at 77:56:40 and at a location of 2.4 degrees south latitude and 27.9 degrees west longitude. The targeted impact point was 125 miles from the Apollo 12 seismometer, and the actual point was 74 miles away, well within the desired 189 mile radius. The S-IVB impact results are discussed in section 11.0.

The accuracy of the first midcourse correction (table 4-II), which placed the spacecraft on the non-free-return trajectory, was such that a maneuver was not required at the third planned option point. However, because of the oxygen tank incident, a 38-ft/sec midcourse maneuver was performed at 61:29:44 using the descent engine to return the spacecraft to a free-return trajectory. This maneuver alone would have caused the command module to nominally land in the Indian Ocean south of Mauritius Island at approximately 152 hours.

At 2 hours beyond pericyynthion, a second descent propulsion maneuver was performed to shorten the return time and move the earth landing point to the South Pacific. The 263.8-second maneuver produced a velocity change of 860.5 ft/sec and resulted in an initial predicted earth landing point in the Pacific Ocean at 142:53:00. The transearth trip time was thus reduced by about 9 hours.

The first transearth midcourse correction (table 4-III), was performed at 105:18:28 using the descent propulsion system. The firing was conducted at 10 percent throttle and produced a velocity change of about 7.8 ft/sec to successfully raise the entry flight-path angle to minus 6.52 degrees.

Spacecraft navigation for the aborted mission proceeded satisfactorily. Post-pericynthion navigation procedures were designed to support transearth injection, and special data processing procedures were required for dual vehicle tracking prior to entry. Less range data than usual were received from tracking stations during the abort phase because the power amplifier in the spacecraft was turned off for most of the time to conserve electrical power. The small amounts of range data received and the resulting large data arcs, however, were sufficient to maintain navigation accuracies approximately equivalent to those of Apollo 12.

TABLE 4-III.- MANEUVER SUMMARY

(a) Translunar

Maneuver	System	Ignition time, hr:min:sec	Firing time, sec	Velocity change, ft/sec	Resultant pericynthion conditions				
					Altitude above landing site, miles	Velocity, ft/sec	Latitude, deg	Longitude, deg	Pericynthion arrival time, hr:min:sec
Translunar injection	G-IVB	2:35:46.4	350.8	10 039	86.8	8184.4	1.47N	178.52E	77:56:22
First midcourse correction	Service propulsion	30:40:19.6	7.5	23.2	63.2	8277.9	3.34N	178.93E	77:28:39
Second midcourse correction	Descent propulsion	61:29:43.5	34.2	37.8	136.7	8058.4	3.02N	179.29W	77:20:57

(b) Transearth

Maneuver	System	Ignition time, hr:min:sec	Firing time, sec	Velocity change, ft/sec	Resultant entry interface condition				
					Flight-path angle, deg	Velocity, ft/sec	Latitude, deg	Longitude, deg	Entry arrival time, hr:min:sec
Transearth injection	Descent propulsion	79:27:39	263.8	860.5	No entry (vacuum perigee = 80.6 miles)				
Third midcourse correction	Descent propulsion	105:16:28	14.0	7.8	-0.24	36 210.6	28.22S	173.49E	142:40:47
Fourth midcourse correction	Lunar module reaction control	127:39:51.5	21.5	3.0	-6.26	36 210.9	28.23S	173.46E	142:40:46

The unusual spacecraft configuration required that new procedures for entry be developed and verified. The resulting timeline called for a final midcourse correction 5 hours before entry, separation of the service module 4 hours 39 minutes before entry, and undocking of the lunar module at 1 hour 11 minutes before entry. Service module separation was performed using the lunar module reaction control system. Separation velocity following lunar module undocking was provided using pressure in the docking tunnel.

The final midcourse correction maneuver used the lunar module reaction control system. Landing occurred at 142:54:41 in the Pacific Ocean at 21 degrees 38.4 minutes south latitude and 165 degrees 21.7 minutes west longitude, which was about 1 mile from the target point.

5.0 COMMAND AND SERVICE MODULE PERFORMANCE

The performance of the command and service module systems is discussed in this section. The sequential, pyrotechnic, service propulsion, thermal protection, earth landing, and emergency detection systems and all displays, controls, and crew provisions operated essentially as intended and are not discussed. The pyrotechnic system, which performed all desired functions, did exhibit two minor anomalies, which are discussed only in sections 14.1.6 and 14.1.10 of the Anomaly Summary, and two discrepancies in the operation of crew equipment were noted, these being discussed in sections 14.3.1 and 14.3.2 of the Anomaly Summary. Except for these four cases, all other anomalies are generally mentioned in this section but are discussed in greater detail in the Anomaly Summary.

5.1 STRUCTURAL AND MECHANICAL SYSTEMS

At lift-off, measured winds, both at the surface and in the region of maximum dynamic pressure, and accelerometer data indicate that structural loads were well below the established limits during all phases of flight. The predicted and calculated spacecraft loads at lift-off, in the region of maximum dynamic pressure, at the end of first stage boost, and during staging were similar to or less than previous Apollo Saturn V launches. Command module accelerometer data prior to S-IC center-engine cutoff indicate longitudinal oscillations similar to those measured on previous flights. Although longitudinal oscillations in the S-II engine structure and propellant system caused early shutdown of the center engine, the vibrations at the spacecraft during S-II boost had an amplitude less than 0.05g at a frequency of 16 hertz. The maximum oscillation measured during either of the two S-IVB thrust periods was 0.06g, also at a frequency of 16 hertz. Oscillations during all four launch vehicle boost phases were within acceptable spacecraft structural design limits.

All mechanical systems functioned properly. One mechanical anomaly, however, was a gas leak from one of two breech assemblies in the apex cover jettison system, and this problem is discussed in section 14.1.6. In addition, docking tunnel insulation, which normally remains with the lunar module after separation, was noted from photographs to have cracked and expanded radially. Since the cracking is believed to occur during pyrotechnic firing and has been seen in past flights, it is not a problem.

Structural temperatures remained within acceptable limits throughout the mission. However, because of the long cold-soak period following powering down, the command module structure exhibited significantly lower temperatures than has been observed in previous flights.

5.2 ELECTRICAL POWER

5.2.1 Batteries

Command module battery performance was acceptable throughout the mission. Entry battery C had been isolated throughout the flight, and at 58 hours 40 minutes, batteries A and B were also isolated from the spacecraft buses. Batteries A and B were charged a total of three times each during the flight, including once each using power from the lunar module. Following the cryogenic oxygen incident, battery A was twice placed on main bus A to support spacecraft load requirements. Preentry procedures were conducted with the lunar module supplying power to the command module main bus B through the command and service module/lunar module umbilical and with entry battery C supplying power to main bus A. This configuration was maintained from 6 hours 30 minutes prior to entry until 2 hours 30 minutes prior to entry, at which time the lunar module batteries were disconnected and all electrical power loads were assumed by the command module entry batteries.

5.2.2 Fuel Cells

Prior to lift-off, the crew experienced erratic readings from all three fuel cell flow indicators when cycling the switch, but system operation was normal.

During the flight, the three fuel cells operated as expected until the sudden loss of pressure in cryogenic oxygen tank 2, as discussed in section 14.1.1. Fuel cell 3 condenser exit temperature varied periodically. A behavior present on all previous flights, and characteristic of the system under certain operating conditions. Soon after the loss of oxygen pressure in tank 2, fuel cells 1 and 3 lost power and were shut down. Fuel cell 2 sustained the total command and service module load until the depletion of oxygen pressure in tank 1.

Unusual variations in the oxygen flow rates to all three fuel cells were observed in the 3-minute period preceding the tank pressure loss. These variations were caused by the simultaneous pressure excursions taking place in cryogenic oxygen tank 2. The fuel cell 1 regulated nitrogen pressure indication went to the lower limit of the measurement when the pressure in cryogenic oxygen tank 2 dropped. Analysis of related fuel cell parameters confirmed this discrepancy to be a loss of instrumentation readout and not an actual loss of the regulated nitrogen pressure. Performance of fuel cells 1 and 3 degraded within 3 minutes after the oxygen tank 2 pressure dropped. The degradation is considered to have been caused by the fuel cell oxygen shutoff valves closing abruptly because of the shock generated when the bay 4 panel separated. A more detailed discussion is contained in reference 1.

During the mission, the fuel cells supplied approximately 120 kW-h of energy at an average current of approximately 24 amperes per fuel cell and at an average bus voltage of 29.4 volts.

5.3 CRYOGENIC STORAGE

Cryogenic storage system operation was satisfactory until 46:40:09, when the quantity indication was lost for oxygen tank 2 (section 14.1.1). At about 56 hours, the pressure in oxygen tank 2 suddenly dropped to zero and the pressure in oxygen tank 1 began to decay until all primary oxygen was lost. As a result, power was lost from fuel cells 1 and 3, and after oxygen was essentially depleted from tank 1, fuel cell 2 was taken off-line. After the flight, a comprehensive review of the history of cryogenic oxygen tank 2 was made to determine whether an unfavorable condition could have existed prior to launch. This review included test records, materials review dispositions, and failure reports. No positive indication of any unfavorable conditions prior to shipment to the launch site could be found in the testing or inspections conducted. However, to accomplish a modification on the vac-ion pumps, the complete oxygen shelf, including the oxygen tanks, was removed from the service module structure during which the oxygen shelf was accidentally dropped with no apparent damage.

After initial cryogenic oxygen filling during the countdown demonstration test at Kennedy Space Center, tank 2 could not be detanked using the normal procedures. The problem resulted from loose or misaligned plumbing components in the dog-leg portion of the tank fill path. After numerous attempts using gaseous oxygen purges and higher expulsion pressures, the fluid was boiled off through the use of the tank heaters and fans, assisted by pressure cycling. During the detanking sequence, the heaters were on for about 8 hours, but it was believed that no damage would be sustained by the tank or its components because of the protection afforded by internal thermal switches. However, the use of the heaters in detanking required that the switches open under a load of 6 amperes at 65 V dc, twice the normal flight operating conditions, for each heater. Tests show that opening the switches under these conditions will fuse the contacts closed and eventually damage fan motor wire insulation. It is this damage which is believed to have caused the inflight failure in tank 2 and loss of pressure.

Consumable quantities in the cryogenic storage system are discussed in section 7.1.

5.4 COMMUNICATIONS EQUIPMENT

The communications system satisfactorily supported the mission. Both S-band and VHF communications were used until translunar injection, after which the VHF was turned off and the S-band equipment was used until spacecraft power-down at approximately 58 hours. S-band and VHF voice, color television pictures, and real-time and playback telemetry were satisfactory. Uplink and downlink signal strengths corresponded to preflight predictions. Communications system management, including antenna switching, was good.

Prior to the television broadcast at approximately 55 hours, difficulty was experienced with high-gain antenna acquisition for approximately 12 minutes. After a change in spacecraft attitude, satisfactory acquisition was accomplished. Further details concerning this problem are discussed in section 14.1.4.

At approximately 56 hours, the high-gain antenna experienced an apparent switch from narrow to wide beamwidth, with a resultant temporary loss of telemetry data. This occurrence coincided with the oxygen tank pressure loss. Post-separation photographs of the service module show damage to the high-gain antenna, which is attributed to the loss of a service module outer panel. This damage, as discussed in reference 1, caused the beam switch and the resultant loss of data.

From 101:53:00 to 102:02:00 and from 123:05:00 to 123:12:00, the communications system was powered up to the extent necessary to transmit high-bit-rate telemetry data using the omnidirectional antennas. The S-band system was turned on for verification prior to undocking and performed nominally. The VHF/AM and VHF recovery systems were turned on at parachute deployment and operated nominally throughout recovery.

5.5 INSTRUMENTATION

The instrumentation system performed normally except for the following discrepancies, both of which have occurred on previous flights. The suit pressure measurement indicated 0.5 psi below cabin pressure until the command module was powered down. However, when the command module was powered up at 123 hours, the measurement indicated correct values, as discussed in section 14.1.9. The potable water quantity measurement operated erratically for a brief period early in the mission. This anomaly is described in section 14.1.8. The pressure, temperature, and quantity measurements for oxygen tank 2, along with the fuel cell 1 nitrogen pressure transducer failure, are discussed in section 14.1.1, since the anomalous performance of these systems is related to the tank incident.

The service propulsion auxiliary propellant gaging system failed prior to launch and a measurement waiver was granted. The failure, which resulted in shorting of the instrumentation power supply, was caused from fuel leakage into the point sensor module within the tank. Similar failures have occurred on previous flights, and since this system is independent of the primary gaging system, which was operating properly, performance of the mission was not affected.

5.6 GUIDANCE, NAVIGATION, AND CONTROL

Performance of the guidance, navigation, and control system was normal except for two instances. Random motion observed in the sextant shaft during the zero optics mode was operationally prevented by turning off power to the optical system when not in use. This problem occurred during Apollo 12 and is thought to be caused by a buildup of contact resistance in the slip rings of the half-speed resolver in the sextant (section 14.1.3). The crew reported the 0.05g light did not illuminate as required within 3 seconds after the digital computer had indicated 0.05g. A manual procedure was therefore required to start the entry monitor system, which performed nominally throughout the remainder of entry (section 14.1.5). As a result of the aborted mission, all power was removed from the inertial platform, including heaters, for approximately 80 hours. After powering up and coarse aligning the platform to that of the lunar module, the command module was guided to a successful landing within approximately 1 mile of the target location. Because of power restrictions, the circuit breaker for the data storage equipment recorder was left open during entry, and no entry data are available for an entry performance analysis.

All attitude control functions were satisfactory. Initial separation from the S-IVB was performed by thrusting for 4.28 seconds to impart a velocity change of 0.86 ft/sec. After a manual pitch maneuver, the command and service modules were docked with the lunar module. Rate disturbances noted at docking were 0.16 deg/sec peak in pitch and yaw, and 0.60 deg/sec peak in roll.

The passive thermal control modes attempted at 7:43:02 and 32:21:49 were not successful and had to be reinitiated. The attempt at 7:43:02 resulted in a divergent coning angle because the roll rate was established using one rather than two roll engines, as required by the checklist. In addition, an incorrect roll rate was loaded into the digital autopilot. The attempt at 32:21:49 resulted in a divergent coning angle because an unplanned minimum impulse engine firing occurred 13 seconds after initiating the roll rate. The engine firing command (two negative roll engines) was generated when the roll manual attitude switch was changed from the rate-command position to the acceleration-command position. The engine

firing could have been avoided procedurally by disabling all engines before doing any control system switching. The passive thermal control mode attempted at 32:21:49 is compared with a typical case in figure 5.6-1, which shows the adverse effects of two extraneous firings. All subsequent passive thermal control modes using the command and service module were established normally.

NASA-S-70-5825

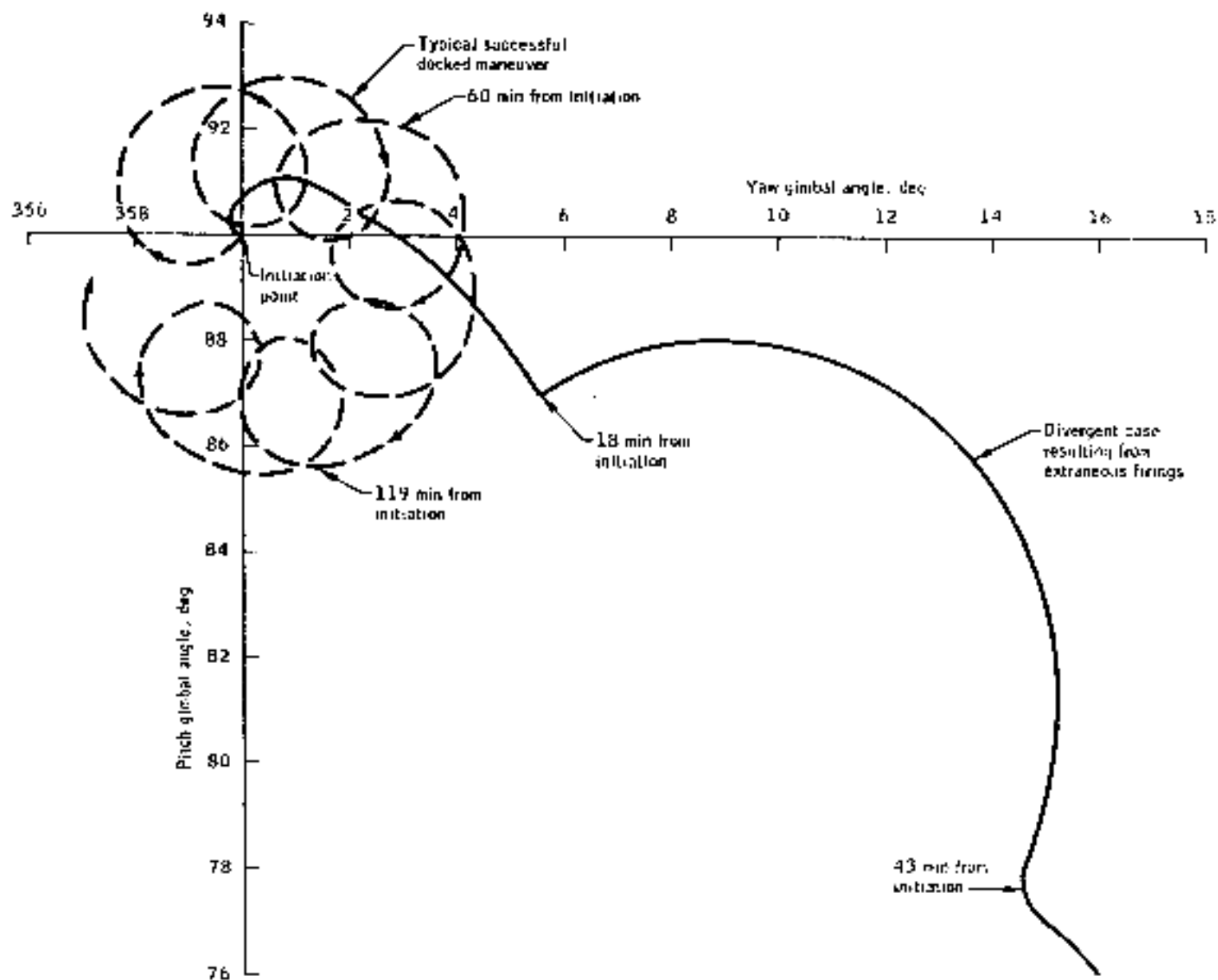

Figure 5.6-1.- Comparison of early translunar maneuver to establish a passive thermal control mode.

At the time of the oxygen tank incident, three events took place that affected control system performance: the quad C isolation valves closed (as discussed in section 14.1.1), a voltage transient caused a computer restart, and the digital autopilot re-initialized the attitude to which it was referenced. The response of the digital autopilot to these events was as programmed, and rate and attitude errors were reduced to a nulled condition within 75 seconds. Reference 1 contains a more complete discussion of spacecraft dynamics during and after the oxygen tank anomaly.

The only translation maneuver performed with the service propulsion system was the first midcourse correction. Spacecraft dynamics during this maneuver were nominal, and significant translation parameters are shown in the following table.

Parameter	First midcourse correction
Time	
Ignition, hr:min:sec	30:40:49.65
Cutoff, hr:min:sec	30:40:53.14
Duration, min:sec	3.49
Velocity gained, ft/sec* (desired/actual)	
X	-13.1/-13.2
Y	-14.7/-14.5
Z	-12.2/-12.3
Velocity residual, ft/sec (spacecraft coordinates)**	
X	+0.1
Y	+0.2
Z	+0.3
Entry monitor system	+0.7
Engine gimbal position, deg	
Initial	
Pitch	0.95
Yaw	-0.19
Maximum excursion	
Pitch	+0.44
Yaw	-0.51
Steady-state	
Pitch	1.13
Yaw	-0.44
Cutoff	
Pitch	1.17
Yaw	-0.44
Maximum rate excursion, deg/sec	
Pitch	+0.08
Yaw	+0.16
Roll	-0.08
Maximum attitude error, deg	
Pitch	-0.04
Yaw	-0.24
Roll	+0.12

*Velocity gained in earth-centered inertial coordinates.

**Velocity residuals in spacecraft coordinates after trimming has been completed.

The crew reported a pitch-up disturbance torque was exerted on the command module soon after undocking until the beginning of entry. Most of this time, only low-bit-rate telemetry was available and therefore a detailed analysis is impossible. A 20-minute segment of high-bit-rate data was received just prior to entry, and an unaccountable pitch-up torque of 0.001 deg/sec^2 was observed. The possible contributing causes for this torque could have been gravity gradients, atmospheric trimming, venting through the umbilical, venting through the tunnel hatch, and a gradual propellant leak. However, none of these is considered to have been a single cause, and either a combination of these causes was present or some undetermined venting took place.

Table 5.6-I is a summary of gyro drift measurements deduced from inflight alignments. The null-bias drift coefficients for all three gyros were updated at 32 hours, based upon drift rates calculated from four platform alignments. The alignment prior to entry was performed by first conducting a coarse alignment to the lunar module platform and then using the automatic optics positioning capability to locate stars for a precise alignment. This technique was necessary because of the difficulty in recognizing constellations through the scanning telescope as a result of reflections from the lunar module and obscuration by vented particles.

TABLE 5.6-I.- PLATFORM ALIGNMENT SUMMARY

Time hr:min	Option code	Star used	Star angle difference, deg	Gyro torquing angles, deg			Gyro drift, mSRU			Comments
				X	Y	Z	X	Y	Z	
06:45		26 Spica, 33 Antares	0.00	+0.167	-0.003	+0.262	--	--	--	
09:28	(a)	35 Rasalhagus, 44 Euf	0.01	+0.175	+0.172	-0.012	--	--	--	
20:40	(b)	29 Deneb, 27 Alkaid	0.00	+0.123	-0.113	+0.092	--	--	--	
23:47	(b)	31 Arcturus, 36 Vega	0.01	+0.283	+0.161	+0.303	+1.4	+0.8	+2.1	Check star 36
28:09	(b)	40 Menkent, 32 Alphecca	0.01	-0.086	+0.075	+0.146	+1.1	+1.0	+1.9	Check star 35
29:07	(b)	23 Denebola, 32 Alphecca	0.00	+0.285	+0.011	+0.131	--	--	--	Check star 31
140:43	(c)	From lunar module primary guidance								
140:52	(a)	36 Vega, 40 Altair	0.00	-1.253	+0.385	+3.263	--	--	--	

^a Preferred alignment

^b Reference matrix (REFSMDAT)

^c Coarse alignment

Table 5.6-II summarizes the inertial component preflight histories. Velocity differences between the S-IVB instrument unit and the command module platform during earth ascent indicate a 75-ft/sec difference in the Y-axis. A Y-axis difference is typical of a command module platform gyrocompassing misalignment at lift-off. However, the Y-axis error magnitude is not typical and is the largest observed during ascent to date. The cause of the discrepancy was the magnitude of the null bias drift

TABLE 5.6-II.- INERTIAL COMPONENT PREFLIGHT HISTORY

Error	Sample mean	Standard deviation	Number of samples	Countdown value	Flight load	Flight average before update	Flight average after update
Accelerometers							
X-Scale factor error, ppm	-199	24	7	+199	-186		
Bias, cm/sec ²	-0.18	0.07	7	-0.26	-0.17	-0.21	-0.11
Y-Scale factor error, ppm	-194	34	7	+194	-190		
Bias, cm/sec ²	+0.30	0.04	7	+0.30	+0.11	+0.13	+0.17
Z-Scale factor error, ppm	+188	38	7	+19	-100		
Bias, cm/sec ²	+0.07	0.06	7	+0.07	+0.04	+0.04	+0.11
Gyroscopes							
X-Hull bias drift, mERU	-0.67	1.28	7	+0.5	^a +0.7	+1.4	+0.73
Acceleration drift, spin reference axis, mERU/g	-1.21	0.73	7	+1.0	+0.0		
Acceleration drift, input axis, mERU/g	+22.91	6.36	7	+12	+8.3		
Y-Hull bias drift, mERU	-1.84	1.86	7	-1.4	^c -0.7	+1.66	+0.04
Acceleration drift, spin reference axis, mERU/g	-0.09	2.05	7	+0.4	+0.0		
Acceleration drift, input axis, mERU/g	+0.11	4.26	7	+1.7	+1.0		
Z-Hull bias drift, mERU	+3.96	1.94	7	-4.0	^d -1.0	+1.19	+1.43
Acceleration drift, spin reference axis, mERU/g	+0.37	2.56	7	-3.3	-1.0		
Acceleration drift, input axis, mERU/g	+19.27	7.14	7	+21.0	+73.0		

^aUpdated to -0.167 at 141:30:00

^bUpdated to +0.6 at 32:04:29

^cUpdated to -1.2 at 32:04:29

^dUpdated to -2.9 at 32:04:29

coefficient for the X-axis, which was still within specified limits; this coefficient being the most sensitive contributor to the gyrocompassing misalignment. Table 5.6-III is a set of error sources which reproduce the velocity errors observed during ascent.

After the oxygen tank incident, the platform was used as a reference to which the lunar module platform was aligned. All power to the guidance and navigation system, including the inertial measurement unit heaters, was removed at about 58 hours. Heater power was applied about 80 hours later, when the inertial measurement unit was put into standby and the computer turned on. Based upon ground test data and two short periods of telemetry, the minimum temperature is estimated to have reached 55° or 60° F before power-up. The only significant coefficient shift observed after the long cold soak was in the Z-axis accelerometer bias. The shift was compensated for by an update at 141 hours from minus 0.04 cm/sec² to the new value of minus 1.66 cm/sec². Although no gyro measurements were obtained just prior to entry, the precision of the landing indicated no large misalignments.

TABLE 5.6-III.- INERTIAL COMPONENT ERRORS DURING LAUNCH

Error term	Uncompensated error	One-sigma specification
Offset velocity, ft/sec		
X	-0.75	--
Y	1.19	--
Z	-0.25	--
Bias, cm/sec ²		
X	-0.04	0.2
Y	0.03	0.2
Z	0.099	0.2
Scale factor error, ppm		
X	-96	116
Y	37	116
Z	-47	116
Null bias drift, mERU		
X	2.7	2
Y	2.0	2
Z	-0.3	2
Acceleration drift, input axis mERU/g,		
Z	9.0	8
Acceleration drift, spin reference axis, mERU/g		
Y	9.0	5

Several entry monitor system bias tests were made during the flight. The associated accelerometer exhibited a stability well within specification limits. Results of each test are given in the following table.

Time	Time interval, sec	Velocity change, ft/sec	Accelerometer bias, ft/sec ²
Before translunar injection	100	+0.8	+0.008
After translunar injection	100	+1.0	+0.010
10 hours 5 minutes	100	+1.8	+0.018
29 hours 40 minutes	100	+1.5	+0.015

5.7 REACTION CONTROL

5.7.1 Service Module

All service module reaction control parameters were normal from lift-off to the time of the oxygen tank anomaly. A total of 55 pounds of propellant was used for the initial separation from the S-IVB, the turnaround maneuver, docking and ejection. Prior to the tank anomaly, propellant usage was 137 pounds, 33 pounds less than predicted for that point in the mission.

Following the anomaly, all reaction control quads except C began showing evidence of frequent engine firings. Data show that all propellant isolation valves on quad C, both helium isolation valves on quad D, and one helium isolation valve on quad B were shocked to the closed position at the time of the oxygen tank pressure loss. On quad D, the regulated pressures dropped momentarily as the engines fired with the helium isolation valves closed. The crew reopened the quad D valves, and the engines functioned normally thereafter. Because the quad C propellant isolation valves are powered from bus B, which lost power, the valves could not be reopened and the quad remained inactive for the remainder of the flight.

During the peak engine activity period after the oxygen tank incident, engine package temperatures reached as high as 203° F, which is normal for the commanded duty cycles. All reaction control data were normal for the configuration and duty cycles that existed, including the quad C data which showed the system in a nonuse configuration because the isolation valves were closed. System data were normal when checked prior to entry at about 123 hours, at which time the total propellant consumed was 286 pounds (86 pounds from quad A, 65 from B, 33 from C, and 102 from D).

5.7.2 Command Module

The command module reaction control system helium pressures and temperatures and the helium manifold pressures were normal from lift-off to system activation just prior to entry. The pressures before activation reflected the general cooling of the system resulting from the powered down configuration of the command module. The helium source temperatures dropped from 70° to about 35° F during the mission. Prior to system activation the lowest engine injector temperature was 15° F. A preheat cycle brought injector temperatures to acceptable levels and hot firing checks were satisfactory.

Just prior to undocking, two injector temperatures were 5° F below minimum. However, engine operation was expected to be normal, despite the low temperatures, and undocking was performed without heating the engines.

System decontamination at Hawaii was normal, except that the system 1 fuel isolation valve was found to be in the open position. All other propellant isolation valves were in the normal (closed) position. Power from ground servicing equipment was used to close the valve, which operated normally. Postflight investigation of this condition revealed that the electrical lead from the system 1 fuel-valve closing coil was miswired, making it impossible to apply power to this coil. This anomaly is discussed in section 14.1.7.

All available flight data and the condition of the system prior to deactivation at Hawaii indicate that the system performed normally from activation through the propellant dump and purge operation.

5.8 ENVIRONMENTAL CONTROL

During the periods when it was activated, the command module environmental control system performed normally. From the time of powering down at approximately 58 hours until reactivation approximately 1-1/2 hours before entry, environmental control for the interconnected cabins was maintained using lunar module equipment. Two anomalies associated with the environmental control instrumentation occurred and are discussed in sections 14.1.8 and 14.1.9. An additional discrepancy, noted after landing and discussed in section 10.3, was the position of the inlet postlanding ventilation valve at the time of recovery. This discrepancy is discussed in section 14.1.2.

The oxygen distribution system operated nominally until deactivation following the cryogenic tank incident. The suit compressor was turned off at 56:19:58, and with the repressurization package off line, the surge

tank was isolated 17 minutes later at an indicated pressure of 858 psia. The 20-psi system was reactivated briefly four times from the surge tank to pressurize the command module potable water system. Further discussion of oxygen usage is presented in section 7.1. System operation for entry was satisfactory, with the suit compressor limited to a period of operation of only 22 minutes to conserve electrical power.

During the period when the command module was powered down, the cabin temperature slowly decreased to approximately 43° F and considerable amounts of moisture condensed on the spacecraft windows and the command module structure. Thermal control, after powering up at 140 hours, was satisfactory, although the cabin temperature remained very cold during entry. The command module potable water served as the main drinking supply for the crew during the mission, and approximately 14 pounds were withdrawn after powering down, using the 8-ounce plastic bags. The crew reported at approximately 120 hours they were unable to withdraw water from the potable tank and assumed it was empty. Approximately 6 hours after landing, the recovery crew was also unable to obtain a water sample from either the potable or waste water tanks. The recovery personnel stated the structure near the tank and lines was very cold to touch, and an analysis of temperatures during the flight in this vicinity show that freezing in the lines most likely occurred. This freezing condition could have existed at the time a sample was to be taken. When the spacecraft was returned to the manufacturer's plant, 24.3 pounds were drained from the potable tank. The water system was subsequently checked and was found to operate properly. Both the hot and cold potable water contained gas bubbles. To eliminate these gas bubbles, which had also been experienced on previous missions, a gas separator cartridge was provided but not used.

The auxiliary dump nozzle was used for the first time on an Apollo mission. Dumping through this nozzle was discontinued and urine was subsequently stored onboard because a considerable number of particles were evident on the hatch window and these interfered with navigation sightings.

Upon recovery, the outlet valve of the postlanding ventilation was open and the inlet valve was closed, whereas both valves should have been open. This condition is reported in section 10.3.2, and the anomaly is discussed in section 14.1.2.

6.0 LUNAR MODULE PERFORMANCE

The performance of the lunar module systems is discussed in this section. All systems that are not discussed either performed as intended or were not used. Discrepancies and anomalies are generally mentioned but are discussed in greater detail in the Anomaly Summary, sections 14.2 and 14.3.

6.1 STRUCTURAL

The structural evaluation is based on guidance and control data, cabin pressure measurements, command module acceleration data, photographs, and crew comments.

Based on measured command module accelerations and on simulations using actual launch wind data, lunar module loads were within structural limits during launch and translunar injection. Loads during docking and service propulsion and descent propulsion maneuvers were also within structural limits.

Data telemetered during the oxygen tank incident indicate the presence of body bending oscillations in the docked spacecraft. The associated amplitudes, however, were of a very low level, and bending loads in the critical docking-tunnel area were well below design limits.

6.2 ELECTRICAL POWER

The electrical power system performed all required functions. At lunar module undocking, the descent batteries had delivered 1434.7 ampere-hours from a nominal total capacity of 1600 ampere-hours, and the ascent batteries had delivered 200 ampere-hours from a nominal total of 592 ampere-hours. The lunar module initial powered-down configuration required an average electrical energy consumption of 900 watts at 30 amperes. After the second descent propulsion firing, the lunar module was further powered down to about a 360-watt (12-ampere) level; as discussed in section 7.2. A false battery 2 malfunction and master alarm occurred at 99:54:00 and continued intermittently during the periods that the battery was on (discussed in section 14.2.3). A review of the data indicates that a current surge of greater than 100 amperes occurred at 97:13:56 concurrent with a crew report of a thumping noise and snowflakes seen through the lunar module window. This occurrence is discussed in section 14.2.2.

6.3 COMMUNICATIONS EQUIPMENT

S-band communications were nominal from system actuation at approximately 58 hours through lunar module undocking. Except for brief periods when high-bit-rate data and high-quality downlink voice were required, low power transmissions, backup voice, and omnidirectional antennas were used to conserve electrical power. The S-band power amplifier was turned off by opening the circuit breaker to provide the higher modulation index for telemetry. The primary communications configuration was low power, low-bit-rate telemetry, omnidirectional antennas, and backup voice on baseband. In this configuration, transmission of high-bit-rate data from the spacecraft was attempted using a 210-foot receiving antenna, and except for regular intervals of data dropout because of vehicle attitude changes, these data were of good quality.

The updata link was used when required and performed nominally. No VHF equipment was exercised, and the S-band steerable antenna was never turned on. The antenna heaters, which normally remain activated, were turned off to conserve power, and the antenna temperature decreased to approximately minus 66° F. In the passive thermal control mode, this temperature varied between plus and minus 25° F.

6.4 GUIDANCE, NAVIGATION AND CONTROL

System performance, with one exception, was nominal during all phases. At completion of the maneuver to the attitude for the last midcourse correction, the attitude error needles were not zeroed because of an out-of-sequence turn-on procedure for the digital autopilot and the inertial measurement unit.

6.4.1 Attitude Control

The performance of the abort guidance system and all attitude control aspects of the digital autopilot were nominal. Following the service module oxygen tank anomaly, power was applied to the primary guidance system for use in establishing passive thermal control modes and to maintain attitude control until the transearth injection maneuver.

The passive thermal control mode after transearth injection was initiated using the digital autopilot in the manual minimum impulse mode. The crew had considerable difficulty in establishing acceptable initial conditions for the passive thermal control mode. This difficulty was largely caused by the necessity to use the translation hand controller

to command rotation about the vehicle pitch and roll axes and the attitude controller for yaw commands. The pilot's task was further complicated by having the flight director attitude indicators powered down. Without these displays, it was necessary to monitor attitudes by observing gimbal angles on the display and keyboard assembly. Because the spacecraft yaw axis was not coincident to that of the platform yaw axis, either a pitch or roll command would cause a change in both of the corresponding gimbal-angle displays. After the vehicle attitude was changed to more closely align with the platform and to reduce the yaw gimbal-angle disparity, passive thermal control was established satisfactorily. Both guidance systems were then powered down until 105 hours. At that time, the abort guidance system was powered up for control during the first transearth midcourse correction. The passive thermal control mode was reestablished and the abort system was powered down.

After completing the maneuver to the attitude required for the final midcourse correction, the crew reported that the attitude error needles were not nulled on the flight director attitude indicator. The sequence used to power up the platform and to enable the autopilot prevented certain computer memory cells from being properly initialized. Consequently, an attitude error bias was introduced between the stored values of attitude error and those displayed on the attitude error needles. When the digital autopilot is turned on, a computer routine checks the status of an "error counter enable" bit to see if initialization is required. If this bit is off, as it normally would be, initialization takes place and the error counter, certain memory cells, and the inertial coupling display unit digital-to-analog converters are all zeroed. If the computer check finds the error counter enabled, the assumption is made that initialization has already taken place and the calculated attitude error is set into the error counter for subsequent display.

The error counters for the coupling display units are used by the digital autopilot for attitude error displays, but are also used to drive the platform during a coarse alignment. A platform coarse alignment was performed at about 135 hours, and the error-counter-enable status bit was set. The digital autopilot was activated 2 hours later, but with the error counters already enabled, no initialization took place and a bias was introduced into the attitude error loop. The attitude errors displayed to the crew at the completion of the attitude maneuver prior to the seventh midcourse correction reflected a bias in the pitch, roll, and yaw axes of plus 1.3, plus 21.2, and minus 12.0 degrees, respectively.

Spacecraft dynamics were very small during the service module jettison and lunar module undocking sequence. Velocity changes imparted to the respective vehicles during each maneuver were as follows:

	Platform-sensed velocity changes, ft/sec					
	Command module axes			Lunar module axes		
	X	Y	Z	X	Y	Z
Service module separation						
Plus X translation				0.67	-0.08	0.01
Minus X translation				-1.90	0.01	-0.04
Lunar module undocking	-1.54	0.42	1.00	-0.65	-0.02	0.00

6.4.2 Translation Maneuvers

Table 6.4-I summarizes the pertinent control system parameters during each translation maneuver. Spacecraft dynamic response during all maneuvers was normal.

The throttle profile for the first midcourse correction performed by the lunar module was 5 seconds at 12.7 percent followed by 27 seconds at 40 percent. The firing was preceded by a 10-second, four-jet ullage maneuver. A number of plus-X firings occurred during the maneuver because pitch and roll thrusters were not inhibited by a Verb 65 entry, as required by the checklist.

The transearth injection maneuver was performed with the primary guidance system controlling the descent propulsion system. The throttle profile was 5 seconds at 12.6 percent, 21 seconds at 40 percent, and the remainder at full throttle. During both periods of throttle increase, the roll-gimbal drive actuator traveled approximately 1.35 degrees negatively from its value at ignition. These excursions were somewhat larger than expected, but simulations have since shown them to be normal and result from engine compliance and mistrim. Spacecraft dynamics were nominal throughout the firing. The first transearth midcourse correction was the last maneuver to use the descent propulsion system. The maneuver was performed by manually controlling pitch and roll using the hand controllers and by automatically controlling yaw with the abort guidance system attitude-hold mode. The 14-second firing was accomplished at 10-percent throttle with no adverse dynamics.

6.4.3 Alignment

The lunar module platform was coarse aligned to the command module platform a few hours after the oxygen tank incident in preparation for

TABLE 6.4-I.- LUNAR MODULE MANEUVER SUMMARY

Condition	Maneuver			
	Second midcourse correction	Transearth injection	Third midcourse correction	Fourth midcourse correction
	PGNS/DPS	PGNS/DPS	AGS/DPS	AGS/DPS
Time				
Ignition, hr:min:sec	61:29:43.49	79:27:38.95	175:18:28	137:39:51.5
Cutoff, hr:min:sec	61:39:17.72	79:32:02.77	175:18:42	137:40:13
Duration, sec	54.23	263.82	14	21.5
Velocity change before trim (actual/desired)				
X*	+3.0/+2.9	-425.9/-425.4	7.0/7.8**	-1.2/-1.5
Y	-14.2/-14.3	+644.6/+645.6		-1.9/-2.2
Z	-15.5/-16.2	+378.8/+379.0		-1.2/-1.5
Velocity residual after trim, ft/sec				
X	+0.2	+1.0	0**	0
Y	0.0	+0.3		0.1
Z	+0.3	0.0		0
Gimbal drive actuator, in.			Not applicable	Not applicable
Initial				
Pitch	-0.02	+0.13		
Roll	-0.34	-0.28		
Maximum excursion				
Pitch	+0.31	+0.16		
Roll	-0.27	-0.44		
Steady-state				
Pitch	+0.04	+0.21		
Roll	-0.51	-0.55		
Cutoff				
Pitch	+0.10	+0.23		
Roll	+0.31	-0.55		
Maximum rate excursion, deg/sec				
Pitch	+0.6	+0.2	+0.2	+0.2
Roll	-0.8	+0.8	-0.6	+0.2
Yaw	+0.2	+0.4	+0.2	+0.2
Maximum attitude excursion, deg				
Pitch	-3.62	-1.6	-0.6	-0.4
Roll	+1.69	+6.7	+0.9	-0.6
Yaw	-1.60	-1.2	+0.4	+0.4

*Earth-centered inertial coordinates.

**Change in velocity shown in body X-axis for descent propulsion firings under control of abort guidance system.

the midcourse correction to enter a free-return trajectory. In preparing for the transearth injection maneuver, a check of the platform alignment accuracy was completed by letting the computer point the alignment optical telescope at the sun as though marks were to be taken. Results of the sun check angles indicated a platform misalignments about any axis of approximately half the allowable 1-degree limit; therefore, a platform realignment was not required before the maneuver.

The primary guidance system was powered up at 133-1/2 hours, after which a coarse alignment to the abort guidance system was performed. The spacecraft axes had previously been aligned to an inertial reference using the abort guidance system by sighting on the earth with the crew optical alignment sight. Alignment accuracy was refined by performing a realignment using the sun and moon as sighting targets for the alignment optical telescope. The star-angle difference of minus 1.12 degrees resulted almost entirely from approximations in stored lunar and solar ephemeris data and computer routines used to calculate sun and moon position vectors.

6.4.4 Inertial Measurement Unit

The inertial measurement unit performed properly throughout the mission. A preflight history of the inertial components and the inflight accelerometer bias measurements are given in the following table.

Error	Sample mean	Standard deviation	Number of samples	Countdown value	Flight load	Flight average
Accelerometers						
X - Scale factor error, ppm	-681	5	4	-689	-700	
Bias, cm/sec ²	+1.47	0.06	4	+1.4	+1.49	+1.50
Y - Scale factor error, ppm	-1165	18	4	-1173	-1190	
Bias, cm/sec ²	-1.42	0.065	4	-1.42	-1.42	-1.35
Z - Scale factor error, ppm	-244	61	4	-292	-310	
Bias, cm/sec ²	+1.56	0.017	4	+1.57	+1.56	+1.52
Gyroscopes						
X - Null bias drift, mERU	+1.18	1.33	4	+0.2	+0.4	
Acceleration drift, spin reference axis, mERU/g	-0.93	1.19	4	-2.6	-1.0	
Acceleration drift, input axis, mERU/g	-5.38	2.37	4	-5.5	-4.0	
Y - Null bias drift, mERU	+0.13	0.30	4	0.0	+0.1	
Acceleration drift, spin reference axis, mERU/g	+5.65	2.75	4	+6.4	+7.0	
Acceleration drift, input axis, mERU/g	+6.35	1.70	4	+7.6	+5.0	
Z - Null bias drift, mERU	-1.10	1.01	4	-1.8	-0.1	
Acceleration drift, spin reference axis, mERU/g	0.28	0.82	4	-0.5	0.0	
Acceleration drift, input axis, mERU/g	-2.53	1.01	4	-3.3	-2.0	

6.4.5 Abort Guidance System Performance

Abort guidance system performance was nominal. No instrument calibrations or compensation updates were performed. Uncompensated accelerometer biases and gyro drifts remained within normal operating limits even though heater power was removed from the abort sensor assembly for most of the flight to conserve electrical power. At times, the sensor package temperature was as low as 37° F.

Accelerometer bias shifts associated with the 30-day and 3-day requirements were well within specification. Table 6.4-II contains pre-flight calibration histories for the initial components of the abort guidance system.

TABLE 6.4-II.- ABORT GUIDANCE SYSTEM PREINSTALLATION CALIBRATION DATA

Accelerometer bias	Sample mean, μg	Standard deviation, μg	Number of samples	Final calibration value, μg	Flight load, μg
X	36.9	16.3	18	57.0	60.0
Y	-32.6	10.0	18	-32.0	-31.0
Z	-1.6	32.2	18	-6.0	-7.0
Accelerometer scale factor		Standard deviation, ppm	Number of samples	Final calibration value, ppm	Flight load, ppm
X		15.0	18	206	206
Y		16.0	18	-1222	-1249
Z		14.0	18	-619	-322
Gyro scale factor	Sample mean, ppm	Standard deviation, ppm	Number of samples	Final calibration value, ppm	Flight load, ppm
X	895	6.7	18	899	898
Y	863	12.9	18	870	870
Z	1492	9.5	18	1501	1502
Gyro fixed drift	Sample mean, deg/hr	Standard deviation, deg/hr	Number of samples	Final calibration value, deg/hr	Flight load, deg/hr
X	0.02	0.08	18	0.11	0.06
Y	-0.30	0.06	18	-0.29	-0.30
Z	-0.52	0.06	18	-0.45	-0.47
Gyro spin axis wobble	Sample mean, deg/hr	Standard deviation, deg/hr	Number of samples	Final calibration value, deg/hr	Flight load, deg/hr
X	0.86	0.10	18	0.90	0.89

6.5 REACTION CONTROL

The reaction control system was activated at about 58 hours. Total propellant consumption was 467 pounds.

About 6 minutes after activation, flight data showed a sizeable decrease (approximately 22 psi) in the system-A propellant manifold pressures. This decrease continued for about 4 or 5 seconds and was accompanied by an increase of 7 and 8 psi in the ascent propulsion system fuel and oxidizer manifold pressures, respectively. These manifold pressure changes indicate a high flow rate from the reaction control system. This was verified by a decrease in the indicated quantity by about 15 pounds. At this same time, the indicated position for the system-A ascent-feed interconnect valves was open.

During passive thermal control modes, the cluster heaters were not used and cluster temperatures ranged from 55° to 97° F.

6.6 DESCENT PROPULSION

With the exception of supercritical helium system performance, descent propulsion system operation, including engine starts and throttle response, was normal.

The descent propulsion system performed normally during the 34.3-second midcourse correction to enter a free-return trajectory. This maneuver was begun at the minimum throttle position (12 percent of full thrust), and after 5 seconds, the throttle position was manually increased to approximately 37 percent, which was maintained for the remainder of the firing. The transearth injection maneuver lasted 264 seconds. Approximately 15 seconds prior to engine shutdown, the pressurization isolation solenoid was closed to avoid a possible problem with propellant-tank fracture mechanics, and the maneuver was completed in the blowdown mode in which residual helium is the sole pressure source. The third system firing, a midcourse correction maneuver, was 13.7 seconds in duration and was performed in the blowdown mode at the minimum throttle position. Upon completion of this third and final descent propulsion operation, more than half the initial propellant load remained.

The supercritical helium pressurization system displayed abnormal performance, beginning with preflight operations. Prelaunch measurements taken during the countdown demonstration test indicated a nominal ground pressure rise rate of 7.8 psi/hr. However, other special tests were performed at various conditions which gave significantly higher rise rates.

The average rise rate from lift-off to the first descent propulsion maneuver was 7.0 psi/hr. Between the first and second firings, the rise rate increased to 10.5 psi/hr, and after the second firing, the rise rate was 33.5 psi/hr. This anomaly is further discussed in section 14.2.1.

At about 109 hours when the helium bottle pressure had reached approximately 1937 psi, the burst diaphragm ruptured and relieved the supercritical system through a special non-propulsive vent. The predicted rupture range for this vehicle was 1900 ± 20 psia. During venting, unexpected motion was imparted to the spacecraft which disrupted the motion established for the passive thermal control mode. The vent tube for the supercritical helium tank is ported on two sides by diametrically opposed oval-shaped holes. It was originally believed that the escaping gas would exit these holes at 90 degrees to the tube axis such that no net thrust is produced. However, the pressure distribution in the tube is such that the two gas plumes have an included angle less than 180 degrees and probably closer to 90 degrees. Therefore, the component of the gas flow along the axis of the vent tube produces a net thrust in the opposite direction which tends to induce a slight roll rate to the vehicle. Since venting of the helium tank would be cause for aborting the mission, the unwanted rolling moment, which is quite small, would have no ultimate effect on a nominal profile. Therefore, the vent tube configuration for future spacecraft will not be changed to one having zero net thrust.

6.7 ENVIRONMENTAL CONTROL

Environmental control system performance was satisfactory during the abort phase of the mission and provided a habitable environment for the crew for approximately 83 hours, nearly twice the time of a nominal flight. Only one anomaly, reverse oxygen leakage through one of the ascent stage shutoff valves, occurred but did not compromise system performance. All crew provisions performed as intended except for cracking of a window shade, discussed in 14.2.5.

An indicated total of approximately 290 pounds of water was used from the lunar module tanks between activation of the sublimator and undocking, and an indicated total of about 50 pounds of water remained. Most of the water used for drinking and food preparation was obtained from the command module potable water tank before 12^h hours, and drinking water was subsequently used from the lunar module tanks. Average water usage rates varied between 2.6 and 6.3 lb/hr.

Total oxygen usage from the three lunar module oxygen tanks was 20.3 pounds over an 82-hour period, for an average usage rate of 0.25 lb/hr. Oxygen remaining in the tanks at undocking was 33.5 pounds. During translunar coast, lunar module cabin leakage was about 0.014 lb/hr, assuming an average cabin pressure of 4.5 psia. Command module cabin leakage was estimated to have been about 0.027 lb/hr. These values indicate an average metabolic consumption rate throughout the flight of approximately 0.21 lb/hr.

The installed primary lithium hydroxide cartridge was used for approximately 27 hours (82 man-hours) following activation of the lunar module at about 58 hours. The secondary cartridge was selected at about 85 1/2 hours. During operation of the lunar module carbon dioxide removal system, the level was permitted to increase to an indicated 14.9 mm Hg. The primary cartridge is nominally rated for a usage capacity of 41 man-hours at 520 Btu/man-hour. The secondary cartridge, nominally rated for about 17.9 man-hours, was used for 8 1/2 hours (25 1/2 man-hours). This cartridge is identical to that used in the portable life support system. A second primary cartridge was installed and used for approximately 6 minutes, but for the remainder of the mission, command module lithium hydroxide cartridges were operated in a special arrangement. One side of each of two command module cartridges was covered and sealed with a plastic bag normally used to store a liquid-cooling garment. As shown in figure 6.7-1, one corner of the bag was sealed to the inlet of the suit circuit hose. The cabin atmosphere then returned to the lunar module suit circuit through these supplemental cartridges by way of the two outlet hoses. The mass flow through this arrangement was partially restricted with tape to properly load the suit-circuit compressors. After approximately 20 hours of operation with two command module cartridges, an additional unit was stacked on each original cartridge to improve the carbon dioxide removal capability. With this supplemental configuration, when only command module cartridges were being used, the indicated carbon dioxide level was maintained between 0.1 and 1.8 mm Hg. The supplemental removal configuration using the command module lithium hydroxide cartridges was assembled and tested on the ground during the flight prior to its actual use in the spacecraft.

Low cabin temperature, resulting from a greatly reduced thermal loading from powered down electrical equipment, was uncomfortable to the crew during the return flight. For most of this time, power levels were maintained between 350 and 400 watts. Environmental equipment operation, however, was normal for this thermal loading, with temperatures of the water/glycol coolant at the sublimator inlet of approximately 46° F. Cabin temperatures were typically between 54° and 60° F, and suit inlet temperatures were maintained between 40° and 41° F during this portion of the flight.

The only anomaly observed in the environmental control system was a reverse leakage from the oxygen manifold through the shutoff valve into the ascent oxygen tank 2. Following the use of oxygen from the tank on two occasions, tank pressure was permitted to increase to the regulated manifold pressure, where it remained for the duration of the flight. The maximum leakage rate through the valve was approximately 0.22 lb/hr. Both the specification leakage rate and the preflight test leakage rate were 0.001 lb/hr. The leaking valve would have presented a problem if this ascent oxygen tank had developed an external leak. Further information regarding this anomaly is contained in section 14.2.4.

NASA-S-70-5826

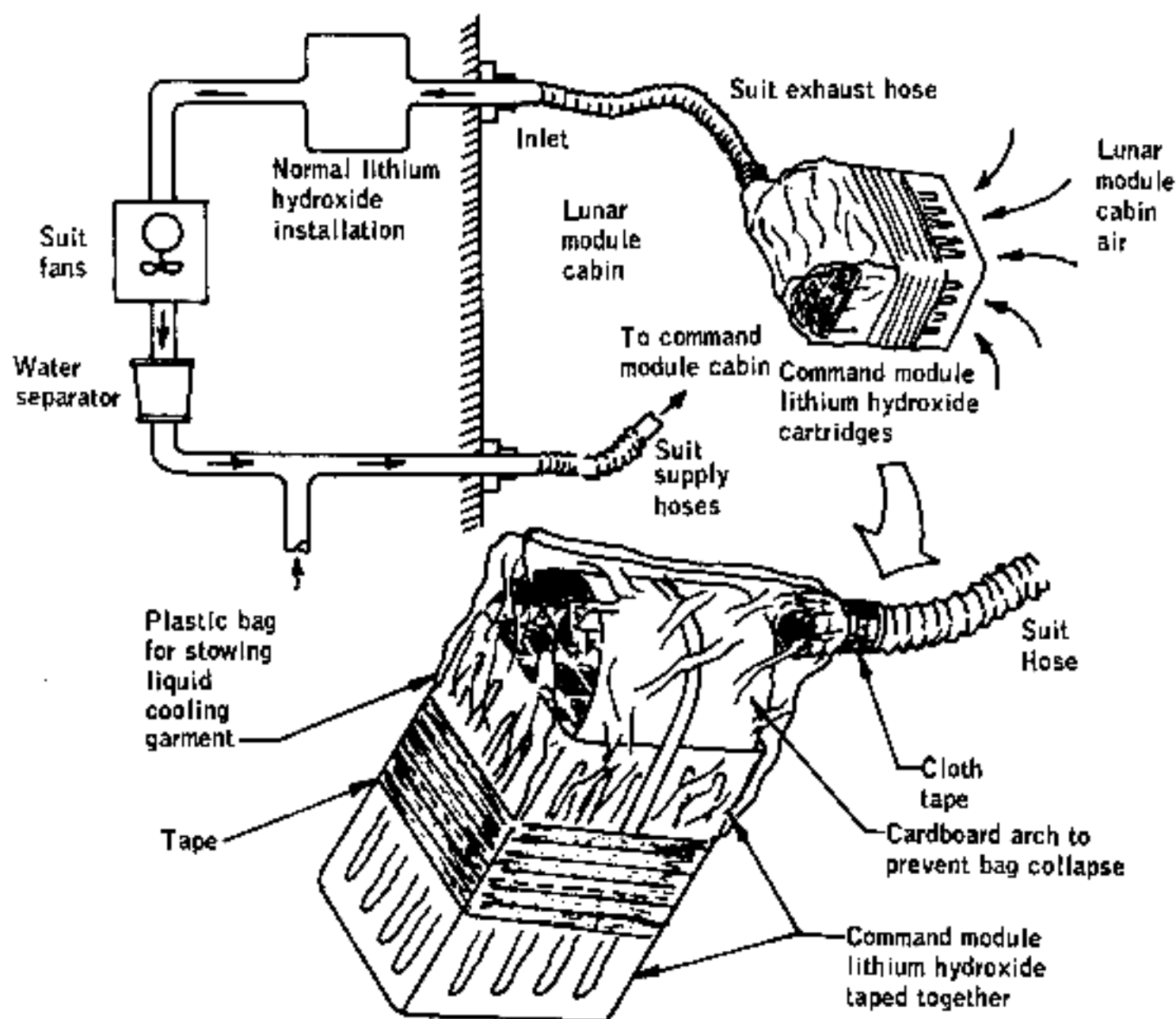

(a) Configuration schematic.

Figure 6.7-1.- Supplemental carbon dioxide removal system.

NASA-S-70-5827

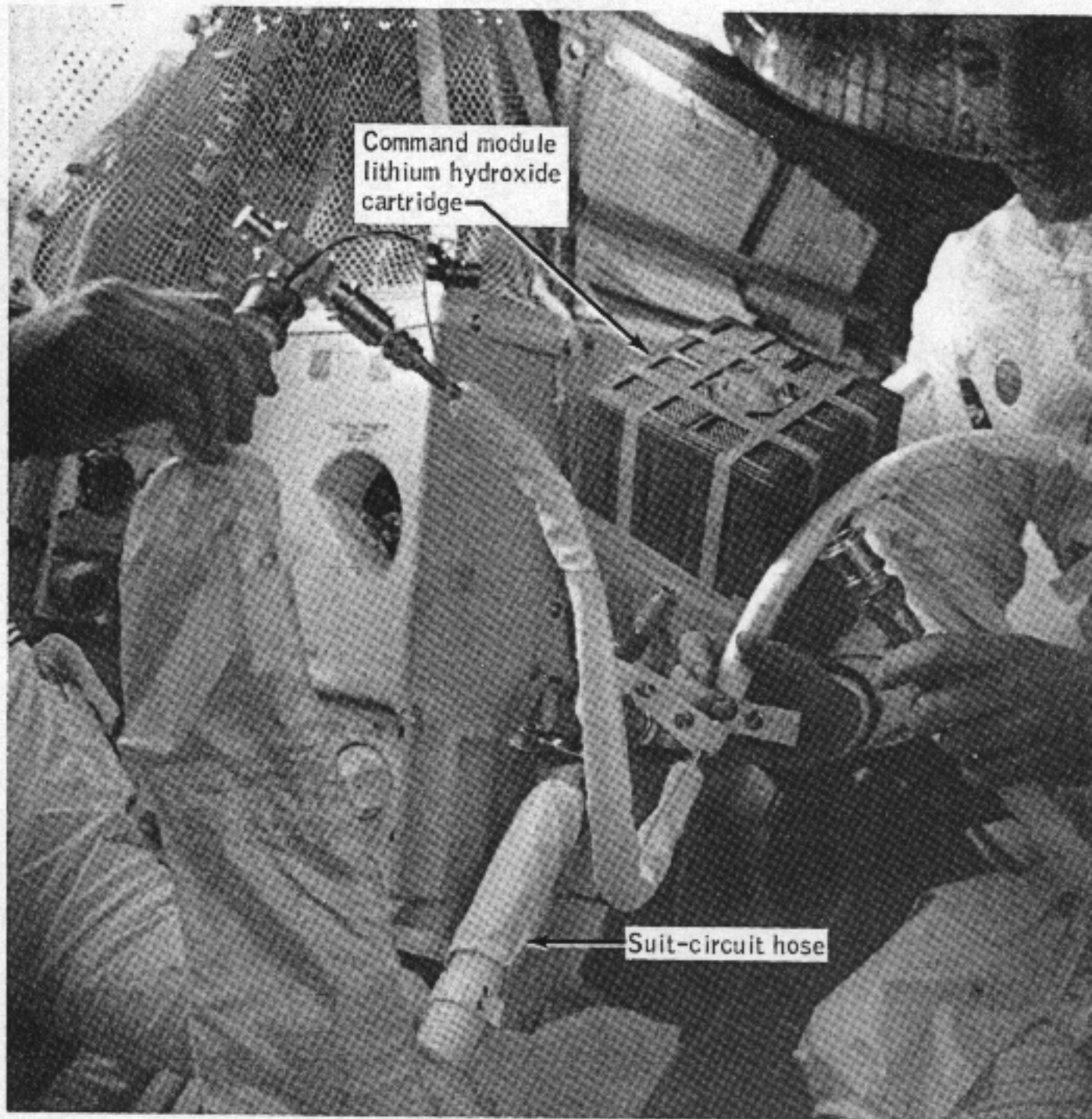

(b) Inflight photograph.

Figure 6.7-1.- Supplemental carbon dioxide removal system.

In using the lunar module water gun to dampen a towel, a piece of towel material most likely became caught in the gun nozzle when the actuating trigger was released, resulting in water leakage from the nozzle. The lunar module water gun was returned to earth and during postflight testing was found to be operating properly. Postflight testing also showed that reactivation of the valve can flush any towel material from the gun. The command module water gun was satisfactorily used for the remainder of the mission.

7.0 MISSION CONSUMABLES

Consumables from the command and service modules were used normally during the 56 hours prior to the incident, at a modified usage schedule for 2 hours after the incident, and after command module activation just prior to entry. The lunar module usages occurred in the period following power-up until the two spacecraft were undocked.

7.1 COMMAND AND SERVICE MODULES

Consumable usages for the command and service modules prior to the incident were nominal. Following the incident and the attendant shut-down of command module power, the only consumables used prior to entry were drinking water and surge-tank oxygen, required to pressurize the potable water tank. Specific consumable usages for appropriate systems are presented in the following paragraphs.

7.1.1 Service Propulsion Propellants

The service propulsion system was used only for the first midcourse correction. The propellant loadings listed in the following table were calculated from gaging system readings and measured densities prior to lift-off.

	Fuel, lb	Oxidizer, lb	Total
Loaded			
In tanks	15 606	24 960	
In lines	<u>79</u>	<u>124</u>	
Total	15 685	25 084	40 769
Consumed	<u>92.3</u>	<u>147</u>	<u>239.3</u>
Remaining at time of incident	15 592.7	24 937	40 529.7

7.1.2 Reaction Control Propellants

Service module.- At the time the system was powered down, reaction control system propellant usage was 108 pounds higher than predicted. The higher usage is attributed to the increased thruster activity required to null the effects of propulsive venting from both oxygen tanks during the incident. The usages listed in the following table were calculated from telemetered helium tank pressure data using the relationship between pressure, volume, and temperature.

	Fuel, lb	Oxidizer, lb	Total
Loaded			
Quad A	110.4	225.6	336.0
Quad B	109.5	225.5	335.0
Quad C	110.1	225.4	335.5
Quad D	<u>110.1</u>	<u>226.2</u>	<u>336.3</u>
	440.1	902.7	1342.8
Consumed			286*
Remaining at time of system shutdown			1056.8

*Preflight planned usage was 178 pounds.

Command module.- Command module reaction control system propellant usages cannot be accurately assessed, since telemetry data were not available during entry. Until the time of communications blackout, approximately 12 pounds of propellant had been used. For a normal entry, this value would be considered high; however, the system was activated longer than normal and was used during separation from the lunar module.

	Loaded quantities, lb	
	System 1	System 2
Fuel	44.2	44.6
Oxidizer	<u>77.8</u>	<u>78.5</u>
Totals	122.0	123.1

7.1.3 Cryogenic Fluids

Cryogenic oxygen and hydrogen usages were nominal until the time of the incident. The pressure decay in oxygen tank 2 was essentially instantaneous, while oxygen tank 1 was not depleted until approximately 2 hours following the incident. Usages listed in the following table are based on an analysis of the electrical power produced by the fuel cells.

	Hydrogen, lb	Oxygen, lb
Available at lift-off		
Tank 1	29.0	326.8
Tank 2	<u>29.2</u>	<u>327.2</u>
Totals	58.2	654.0
Consumed		
Tank 1	7.1	71.8
Tank 2	<u>6.9</u>	<u>85.2</u>
Totals	14.0	157.0
Remaining at the time of the incident		
Tank 1	21.9	255.0
Tank 2	<u>22.3</u>	<u>242.0</u>
Totals	44.2	497.0

7.1.4 Oxygen

Following the incident and loss of pressure in tank 1, the total oxygen supply consisted of 3.77 pounds in the surge tank and 1 pound in each of the three repressurization bottles. About 0.6 pound of the oxygen from the surge tank was used during potable water tank pressurizations and to activate the oxygen system prior to entry. An additional 0.3 pound was used for breathing during entry.

7.1.5 Water

At the time of the incident, about 38 pounds of water was available in the potable water tank. During the abort phase, the crew used juice bags to transfer approximately 14 pounds of water from the command module to the lunar module for drinking and food preparation.

7.1.6 Batteries

The command module was completely powered down at 58 hours 40 minutes, at which time 99 ampere-hours remained in the three entry batteries. By charging the batteries with lunar module power, available battery capacity was increased to 118 ampere-hours. Figure 7.1-1 depicts the battery energy available and used during entry. At landing, 29 ampere-hours of energy remained.

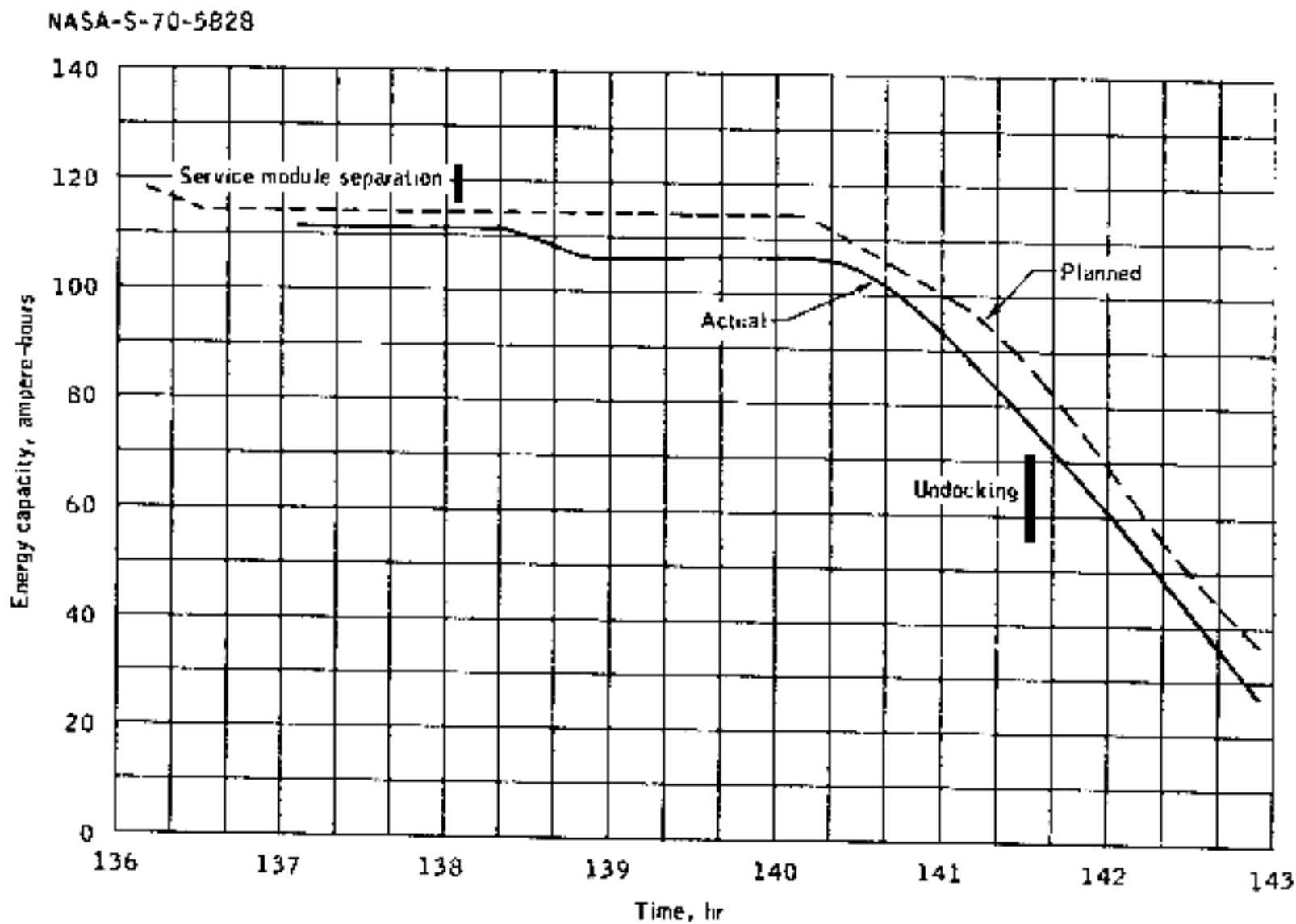

Figure 7.1-1.- Entry battery energy.

7.2 LUNAR MODULE

Following lunar module power-up, oxygen, water, and battery power were consumed at the lowest practical rate to increase the duration of

spacecraft support from a nominal 44 hours to a required 83 hours plus margins. In addition, the descent propulsion and reaction control systems were used to effect all required translation and attitude maneuvers following the incident.

7.2.1 Descent Propulsion Propellants

The loaded quantities of descent propulsion system propellants shown in the following table were calculated from quantity readings in the spacecraft and measured densities prior to lift-off.

	Fuel, lb	Oxidizer, lb	Total
Loaded	7083.6	11 350.9	18 434.5
Consumed	3225.5	5 117.4	8 342.9
Remaining at undocking	3858.1	6 233.5	10 091.6

7.2.2 Reaction Control Propellants

The reaction control system propellant consumption, shown in the following table, was calculated from telemetered helium tank data using the relationship between pressure, volume, and temperature.

	Fuel, lb	Oxidizer, lb	Total
Loaded			
System A	107.7	208.8	316.5
System B	107.7	208.8	<u>316.5</u>
Total			633.0
Consumed			
System A			220
System B			<u>247</u>
Total			467
Remaining at undocking			
System A			96.5
System B			<u>69.5</u>
Total			166

7.2.3 Oxygen

Actual oxygen usage closely followed predicted rates from the time of lunar module power-up until undocking, at which time approximately 32 pounds of oxygen remained. The values in the following table are based on telemetered data.

	Loaded; lb	Consumed, lb	Remaining after undocking, lb
Descent stage	49.3	21.9	27.4
Ascent stage			
Tank 1	2.3		2.3
Tank 2	<u>2.4</u>	<u> </u>	^a <u>2.7</u>
Total	54.0	21.9	32.4

^aThe shutoff valve in ascent stage tank 2 had reverse leakage (discussed in section 14.2.4).

7.2.4 Water

During the abort phase, lunar module water, which is used primarily to cool the cabin and onboard equipment, was the most restrictive consumable. As a result, extreme measures were taken to shut down all nonessential equipment in order to provide the maximum margin possible. At launch, the total loaded water available for inflight use was 338 pounds. At the time of undocking, approximately 50 pounds of water remained and, at the reduced power condition, would have provided an additional 18 hours of cooling. The actual water usage from the time of initial power-up to undocking is shown in figure 7.2-1.

7.2.5 Batteries

At the time of power up, 2179 ampere-hours of electrical energy was available from the four descent- and two ascent-stage batteries. As indicated in figure 7.2-2, initial consumption was at a current of 30 amperes until the second descent propulsion system firing, after which the vehicle was powered down to a 12-ampere load. At approximately 112 hours, power was provided to charge the command module entry batteries at a rate of about 7 amperes for approximately 15 hours. The command module was also powered from the lunar module at an 11-ampere rate for a brief period to

operate the reaction control heaters and telemetry equipment. The estimated total energy transferred to the command module was approximately 129 ampere hours. A total of 410 ampere hours remained in the lunar module batteries at the time of undocking.

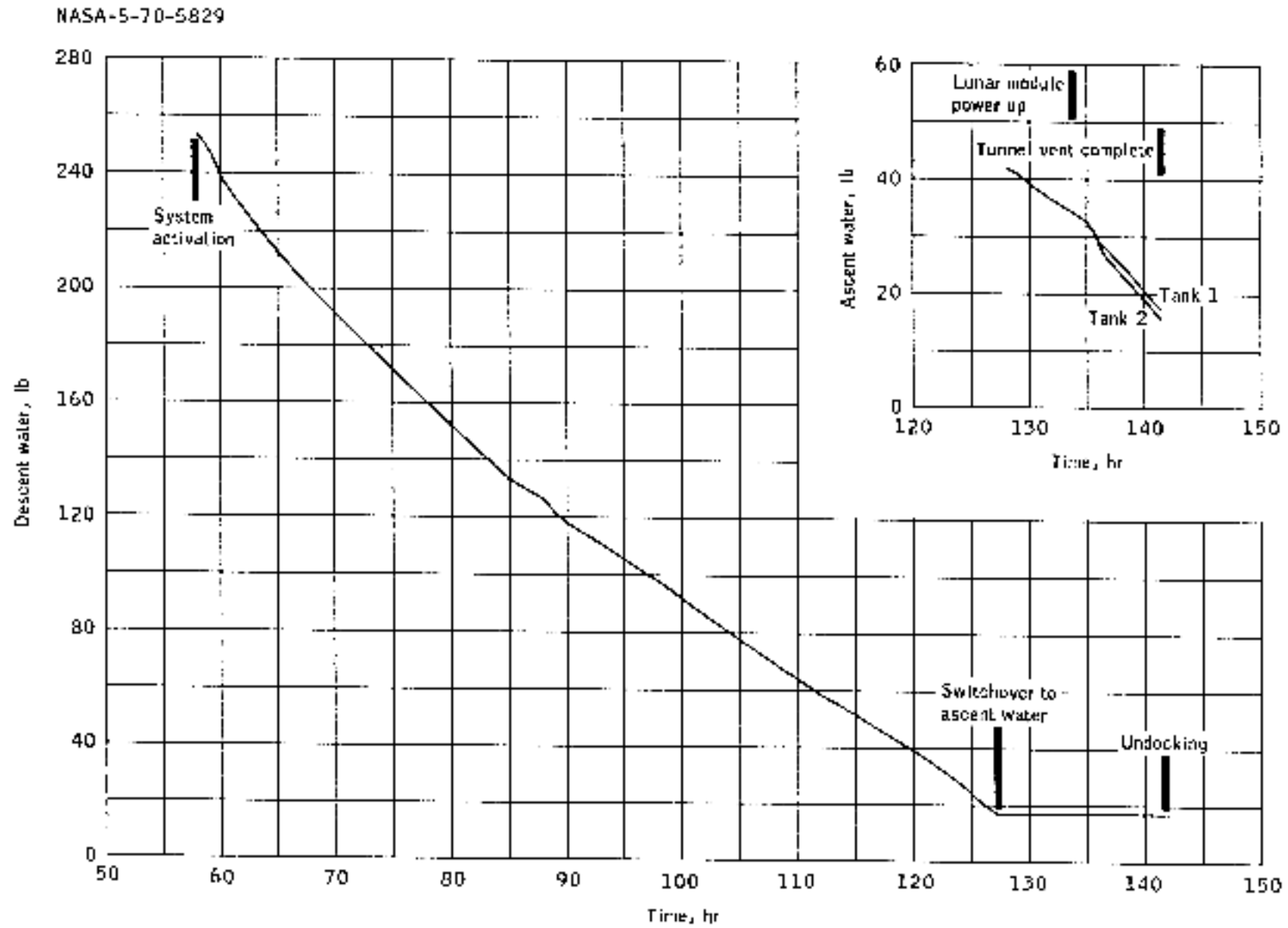

Figure 7.2-1.- Lunar module water usage.

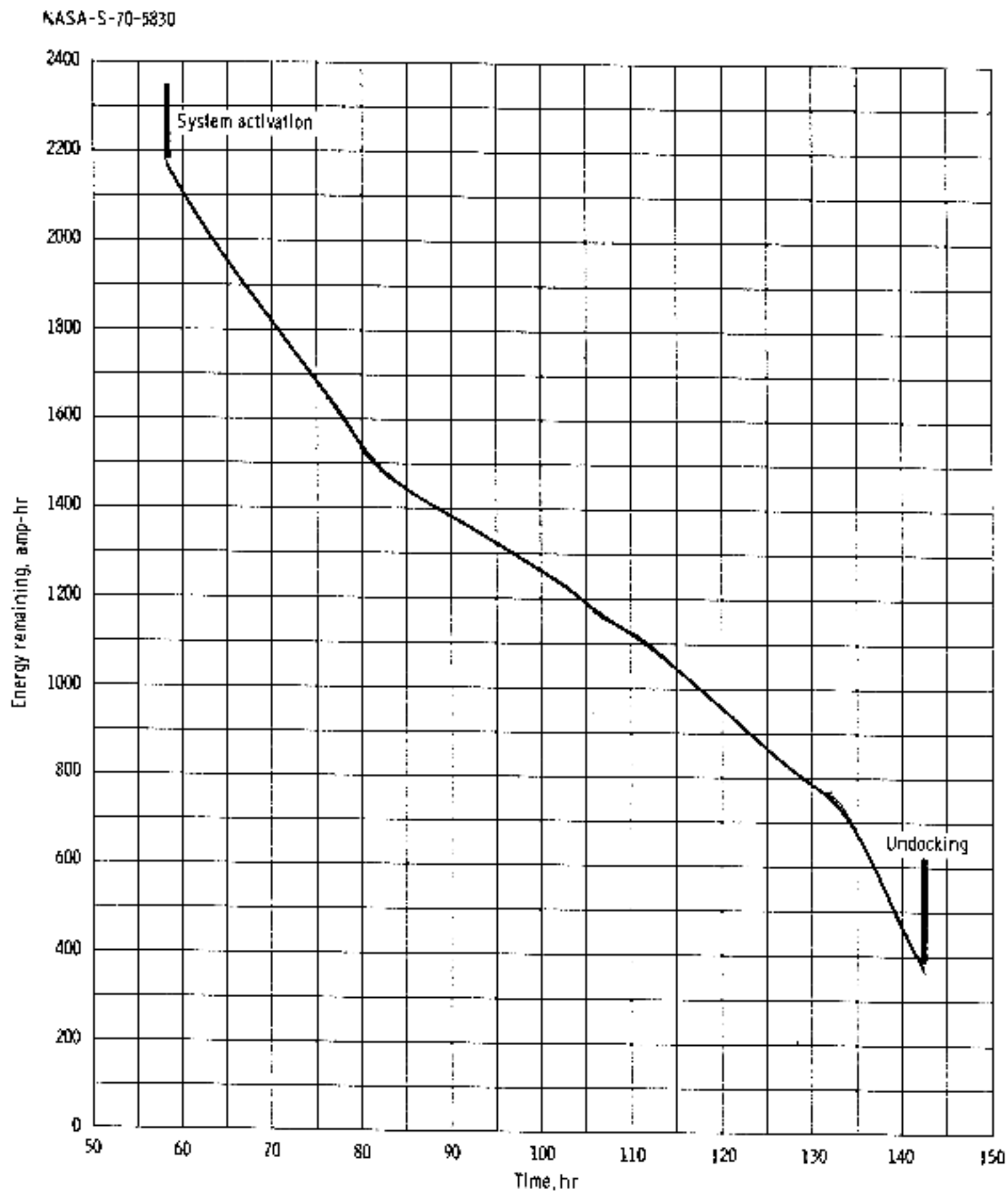

Figure 7.2-2.- Lunar module total battery capacity during flight.

8.0 PILOTS' REPORT

8.1 TRAINING

Crew training for Apollo 13 commenced on August 1, 1969. The crew was based in Houston until December 1, 1969, when operations were transferred to the launch site for final training. The training time was adequate to meet the planned launch date of April 11, 1970, and all training objectives were met. The only difficulty in coordinating the training activities was the scheduling of the lunar landing training vehicle for the Commander. The late availability of this vehicle, the large amount of time required for this type of training, and the need to travel between Houston and Cape Kennedy complicated the training schedule significantly. Because a primary objective was a field geology experiment as part of the second extravehicular excursion, considerable emphasis was placed on geology training. A week-long geology field trip to train the crew as "observers" was completed early in the training cycle. Later field trips emphasized practical geological procedures and timelines. Extensive use of field radios, extravehicular equipment, and assistance from mission control during these field trips made the training more effective.

Several days prior to launch, the backup Lunar Module Pilot became sick with measles. Examinations of the prime crew indicated that the Command Module Pilot was not immune to the disease; therefore, the backup Command Module Pilot was substituted. The last 2 days prior to flight were devoted to integrated training among the three crew members, including the new Command Module Pilot. Flight results indicate that the last minute change of Command Module Pilots was practical and presented no training deficiencies, including readiness for the abort condition that occurred.

8.2 PRELAUNCH PREPARATION

The prelaunch timeline was satisfactory, and adequate time was allotted for suiting and associated activities to meet the ingress time. The final count was smooth and communications with the Test Conductor and the Mission Control Center were adequate. After the fuel cell selector knob was rotated and had been in the new position for a short time, the fuel cell flow indicators would alternately rise several scale marks and then return to normal momentarily before cycling again. Since this effect was observed for all three fuel cells, the possibility of a sensor anomaly was dismissed. With the crew fully strapped down, some difficulty was encountered in removing the helmet protective covers just prior to egress of the closeout personnel.

8.3 LAUNCH

Ignition and lift-off occurred on schedule. A listing of major flight plan events as they occurred is contained in figure 8-1. First-stage performance was nominal and coincided very closely with simulations. Communications during the high noise level phase of flight were excellent. Staging of the S-IC occurred nearly on time and was accompanied by three distinct longitudinal oscillations. S-II ignition and thrusting was smooth until about 00:05:32, when a sudden buildup in vibration was felt, followed by illumination of the number 5 engine out light. The Mission Control Center confirmed that engine 5 had shut down approximately 2 minutes early. S-II performance after that time was smooth with no noticeable abnormalities. S-II staging and S-IVB ignition occurred late, at 9 minutes 57 seconds. S-IVB performance was nominal but seemed to be accompanied by more vibration than was noted during Apollo 8. [The Apollo 13 Commander had been the Command Module Pilot for Apollo 8]. All three crewmen noted the small change in acceleration caused by the mixture ratio shifts during S-II and S-IVB flight. S-IVB engine cutoff occurred at 00:12:30, with the spacecraft guidance system registering the following insertion parameters: velocity 25 565 ft/sec, apogee 102.6 miles, and perigee 100.1 miles.

8.4 EARTH ORBIT

The insertion checklist was completed and disclosed no systems abnormalities. The optics dust covers did not jettison when the shaft was driven 90 degrees (checklist was in error). However, the star alignment program was selected in the computer and the dust covers jettisoned when the optics were being driven to the first star; a shift of approximately 150 degrees. The objective of television in earth orbit was to show the Gulf Coast line, but this objective could not be achieved because of cloud cover. Television preparation was very easily handled within the nominal timeline.

8.5 TRANSLUNAR INJECTION

Nominal first-opportunity translunar injection procedures were used and are satisfactory. Based on S-IVB orbit attitude hold, the ground controllers updated the spacecraft attitude indicators from 18 to 20 degrees. This update was satisfactory and resulted in an essentially zero theta angle in the orbital rate display during the S-IVB translunar injection. S-IVB vibration was greater during translunar injection than that experienced during Apollo 8. These vibrations had high-frequency,

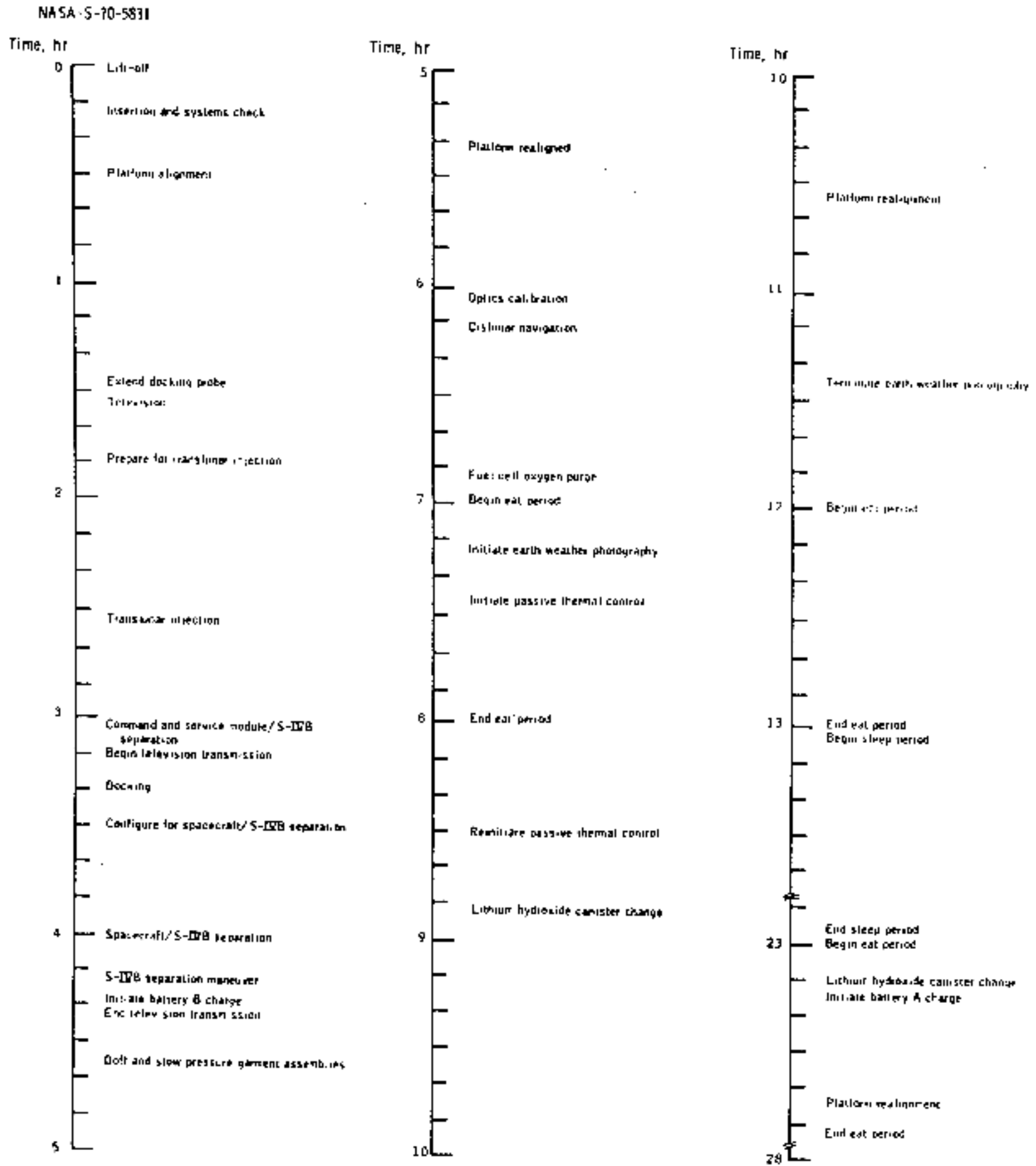

(a) 0 to 28 hours.

Figure 8-1.- Flight plan activities.

NASA-5-70-5832

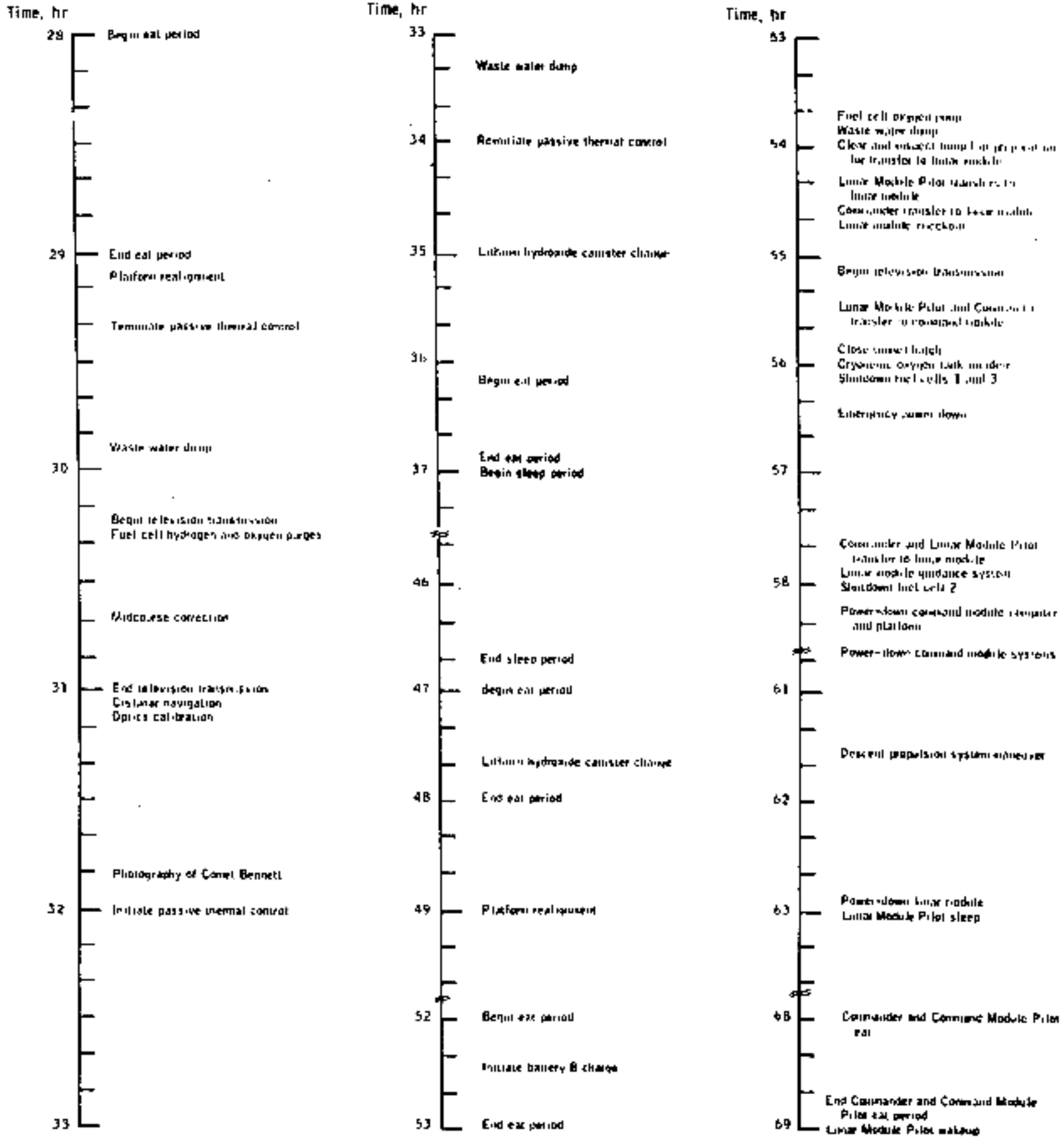

(b) 28 to 69 hours.

Figure 8-1.- Continued

NASA S 70-5833

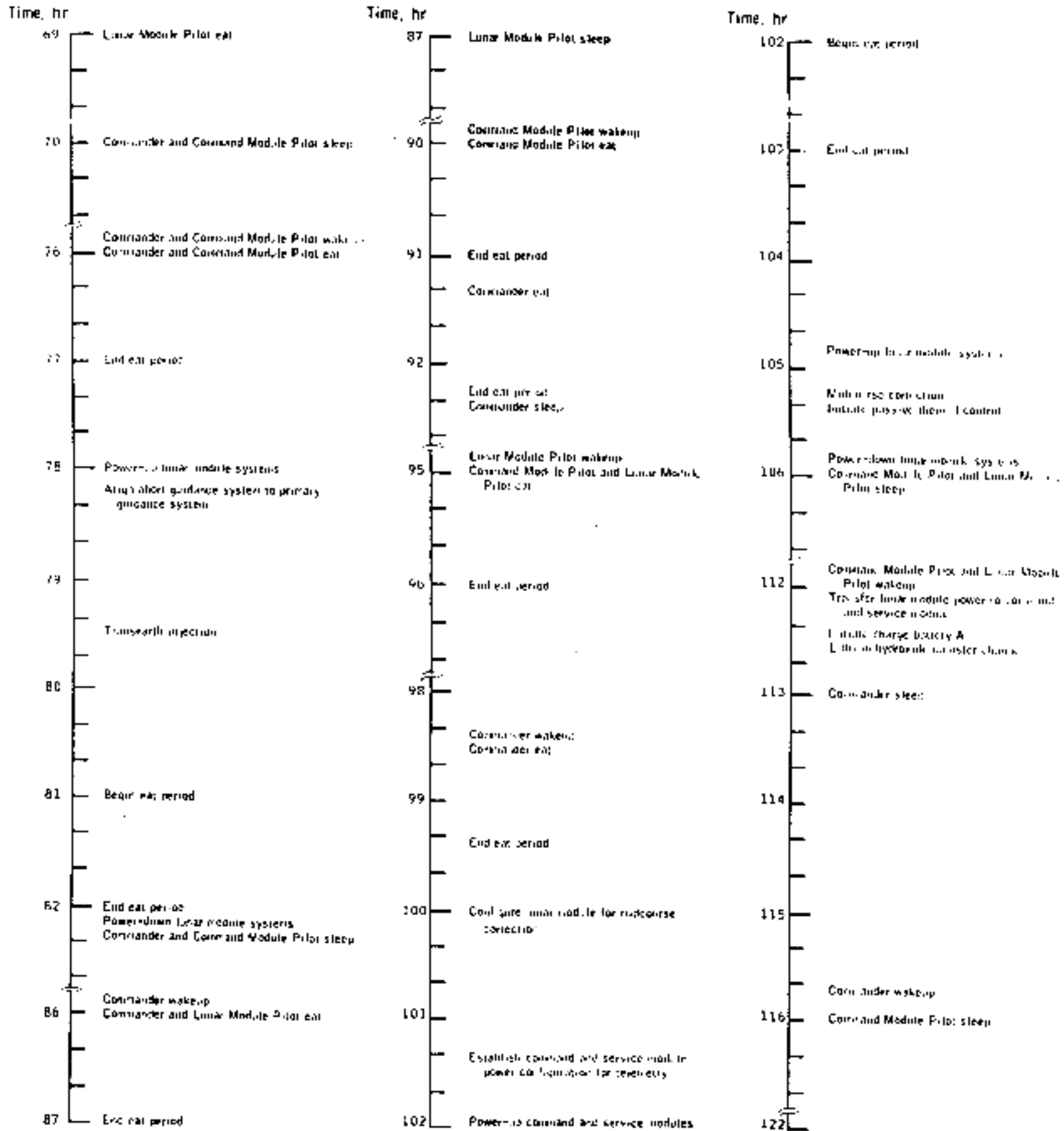

(c) 69 to 122 hours.

Figure 8-1.- Continued.

NASA-S-70-5834

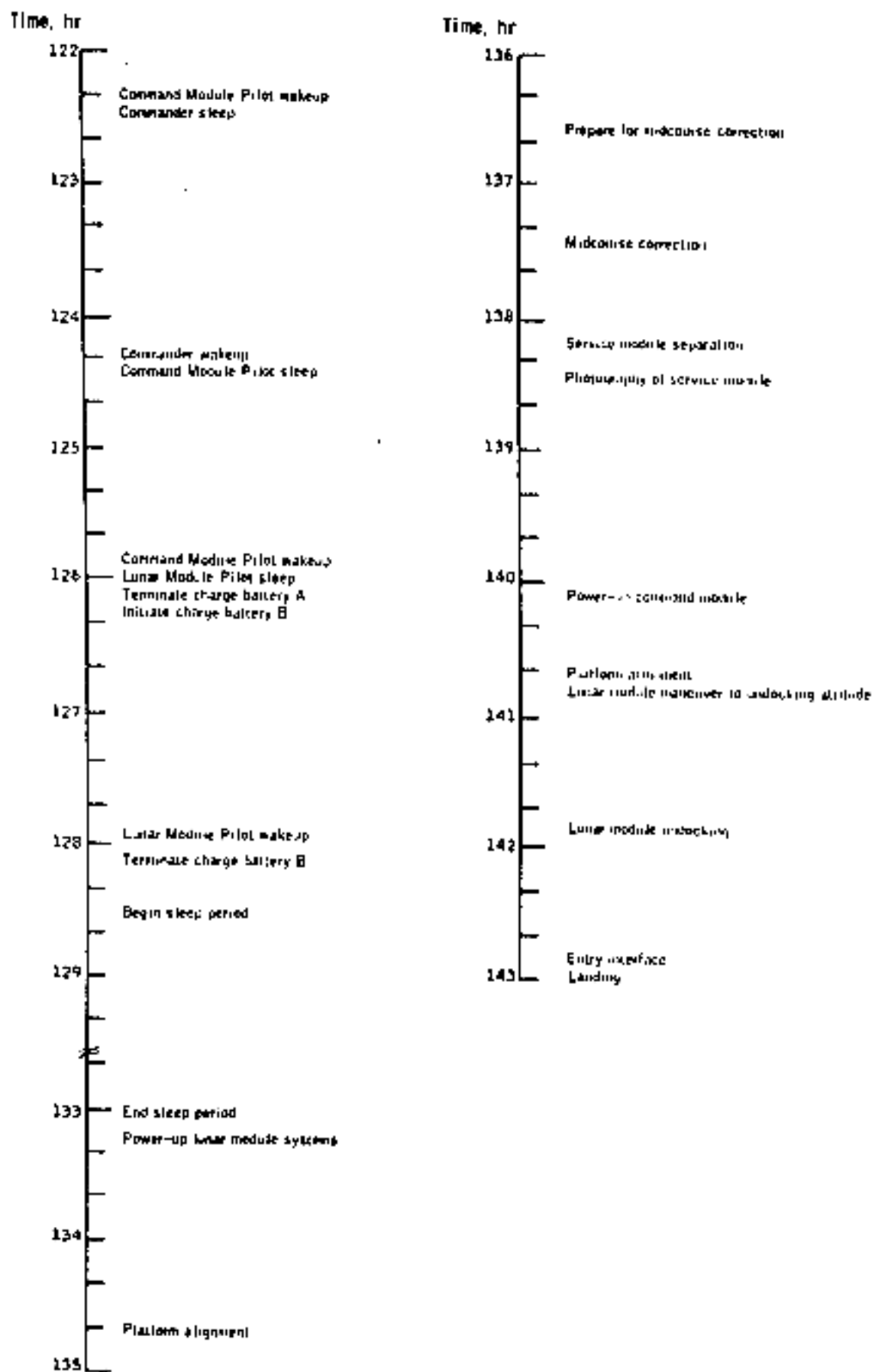

(d) 122 to 143 hours.

Figure 8-1.- Concluded.

low-magnitude characteristics but presented no problems for monitoring of the injection maneuver. At cutoff, the computer-displayed inertial velocity was 35 560 ft/sec, and the entry monitor system accelerometer confirmed the maneuver to be within 3 ft/sec of the desired value.

8.6 TRANSPOSITION AND DOCKING

Following separation and translation, a manual pitch maneuver of 1.5 deg/sec was executed. Computer control was reselected, and a translation was initiated to give a small closing velocity. A digital autopilot maneuver was executed to align the respective roll attitudes. Maximum spacecraft separation was approximately 80 feet. At the final attitude, the image in the crewman optical alignment sight was almost completely washed out by the sun reflection from the lunar module until the vehicles were separated by 6 feet or less. Contact was made at approximately 0.2 ft/sec with a slight roll misalignment. Subsequent tunnel inspection revealed a roll index angle of minus 2.0 degrees. The handles on latches 1 and 4 were not locked and were recocked and released manually. Spacecraft ejection was normal. Total reaction control fuel used for transposition, docking, and extraction was reported as 55 pounds.

8.7 TRANSLUNAR FLIGHT

8.7.1 Coast Phase Activities

Following translunar injection, earth weather photography was conducted for approximately 6 hours.

The first period of translunar navigation (Program 23) at 6 hours was done to establish the apparent horizon attitude for optical marks in the computer. Some manual maneuvering was required to achieve a parallel reticle pattern at the point of horizon-star superposition. The second period of navigation measurements was less difficult, and both periods were accomplished within the timeline and reaction control fuel budget.

The passive thermal control mode was initiated with the digital autopilot. A roll rate of 0.3 deg/sec was used with the positive longitudinal spacecraft axis pointed toward ecliptic north pole. An incorrect entry procedure was used on one attempt and reinitialization of passive thermal control was required. After proper initialization, all thrusters were disabled and the spacecraft maintained an attitude for thermal protection for long periods without approaching gimbal lock. Platform

alignments (Program 52) with passive thermal control mode rates of 0.3 deg/sec were satisfactory in the optics resolve mode at medium speed.

At about 47 hours the oxygen tank 2 quantity sensor failed full scale high, a condition which was confirmed by the ground.

8.7.2 First Midcourse Correction

The first midcourse correction maneuver, performed at the second option point, was completely nominal. The service propulsion engine was started and stopped on time, and residuals were negligible. In conjunction with this service propulsion maneuver, some differences were noted with respect to the command module simulator. When gimbal motors were turned on, an 8- to 10-ampere increase was noted, with a slightly faster jump than had been seen in the simulator. The major distinction was the fact that fuel cell flowrate indications are barely seen to move, whereas there is a very noticeable change in the simulator. At engine ignition, the ball valve indicators moved slowly to open, but in the simulator, they instantaneously move to open. After turning off the battery bus ties, the battery voltage slowly rose from 32 volts to the open circuit voltage of about 37 volts, whereas in the simulator there is an instantaneous recovery.

The television presentation during the midcourse correction maneuver, as well as during transposition and docking, interfered with normal operational functions to a degree not seen in training. The lunar module pilot was forced to spend full time adjusting, pointing, and narrating the television broadcast. A suggested alternative for telecasting during dynamic events is to have the ground do all commentary. Crew-designated television can be conveniently performed during a lull period when full attention can be given to presentation requirements.

8.7.3 Cryogenic Oxygen Tank Incident

At approximately 55 hours 54 minutes, a loud noise was heard when the Command Module Pilot was in the left seat, the Commander in the lower equipment bay, and the Lunar Module Pilot in the tunnel. The noise was comparable to that noted in exercising the lunar module repressurization valve. The Command Module Pilot and Lunar Module Pilot also reported a minor vibration or tremor in the spacecraft.

Approximately 2 seconds later, the Command Module Pilot reported a master alarm and a main-bus-B undervoltage light. Voltage readouts from main bus B, fuel cell 3 current, and reactant flows were normal, and it was concluded a transient had occurred. The Command Module Pilot then initiated efforts to install the tunnel hatch.

The Lunar Module Pilot proceeded to the right seat and found the ac-bus-2 and ac-bus-2-overload warning lights on, with main bus B voltage, fuel-cell-3 current, and fuel-cell-3 reactant flow indications off-scale low. Inverter 2 was then removed from main bus B.

On switching ac electrical loads to ac bus 1, the main bus A undervoltage light illuminated, with a corresponding reading of 25.5 volts. A check of the fuel cells revealed fuel cell 1 reactant flow to be zero. At all times, fuel cells 1 and 2 were tied to main bus A and fuel cell 3 to main bus B, with the proper grey flags displayed.

Efforts to install the tunnel hatch were terminated when the Commander observed venting of material from the service module area. He then reported the oxygen tank 2 pressure was zero and oxygen tank 1 pressure was decreasing. This information pinpointed the problem source to within the command and service modules.

At ground request, fuel cells 1 and 3 regulator pressures were read from the systems test meter, confirming the loss of these fuel cells. AC bus 2 was tied to inverter 1, and the emergency power-down procedure was initiated to reduce the current flow to 10 amperes. At ground request, fuel cell 1 and, shortly thereafter, fuel cell 3 were shutdown in an attempt to stop the decrease in oxygen tank 1 pressure.

Lunar module powerup was handled quite efficiently by identifying selected segments of an existing procedure, the "Lunar Module Systems Activation Checklist." However, the crew had to delete the very high frequency portion of the communications activation. This procedure also assumed suited operations, so the crew had to turn on suit flow valves and unstow hoses to establish air flow. This extended power-up blended well with the preparation for the subsequent midcourse maneuver to enter a free return trajectory. A similar real-time update to the 2-hour activation section of the "Lunar Module Contingency Checklist" was also quite adequate. Lunar module activation was completed at the time fuel cell 2 reactant flow went to zero because of oxygen depletion. The command and service modules were then powered down completely according to a ground-generated procedure. To form a starting baseline for subsequent procedures, each switch and circuit breaker in the command module was positioned according to ground instructions.

Potable water was obtained by periodically pressurizing the potable tank with surge-tank oxygen and withdrawing potable water until the pressures equalized. This method provided potable water for crew use until 24 hours prior to entry, at which time water could not be withdrawn from the potable tank and it appeared to be exhausted [section 5.8].

The hatch, probe, and drogue were secured in the couches by lap belt and shoulder harness restraints to prevent movement during subsequent maneuvers.

8.7.4 Midcourse Correction to a Free Return

A descent propulsion system maneuver to reestablish a free-return trajectory was planned for 61-1/2 hours using primary guidance. The docked configuration was maneuvered manually to null out guidance system error needles using the thrust/translation controller assembly for roll and pitch control and the attitude controller assembly for yaw control. It was not difficult to control the docked configuration in this manner. There was, however, some concern as to the effect the use of the thrust/translation controller assembly would have on the trajectory. After the error needles were nulled, attitude was maintained using primary guidance with attitude control in "Auto."

Primary guidance system performance was nominal during the midcourse maneuver to a free return. There were no vehicle attitude excursions, and the firing time was as predicted. The abort guidance system was not powered up for this maneuver.

After the free-return midcourse correction, the spacecraft was maneuvered manually to the passive thermal control mode attitudes. The passive thermal control mode techniques consisted of maneuvering in the pulse mode 90 degrees in yaw once each hour using the pulse mode. To conserve power, the attitude indicators were turned off after the initial passive thermal control mode was started, and attitude monitoring was accomplished by observing gimbal angle readouts from the display keyboard.

To conserve reaction control fuel when holding an attitude, a wide deadband was established using primary guidance. Because the platform was not aligned with a passive thermal control mode reference matrix, yawing the vehicle each hour resulted in inner and middle gimbal angle deviations. The crew could not determine any standard procedure to keep the middle angle constant during the maneuver. As the spacecraft maneuvered from one quadrant to the next, the same thrust/translation controller assembly input would result in a different effect in controlling the middle gimbal angle.

8.7.5 Platform Alignment

To assure the alignment accuracy of the lunar module platform for the transearth injection maneuver, a check was made at 74 hours utilizing the sun for reference. The method involved a platform alignment program

(P52, option 3), loading the sun vectors, and utilizing an automatic attitude maneuver. The null point was approximately one-half a sun diameter to the right of the sun's edge. A two-diameter offset was allowable, so the platform was considered acceptable.

Initial outside observations through the lunar module windows indicated that normal platform alignments using a star reference would be extremely difficult because of the large amount of debris in the vicinity of the spacecraft. This debris apparently originated during the tank incident. A subsequent observation when the spacecraft was in the moon's shadow indicated that an alignment at that time would have been feasible because of the improved visual contrast. Crew training for sun/earth and sun/moon alignments in the simulators should be emphasized to handle contingencies such as occurred during Apollo 13.

8.8 TRANSEARTH INJECTION

Maneuvering to the proper attitude for transearth injection was done manually with the thrust/translation controller assembly and attitude controller assembly while tracking primary guidance error needles. The error needles were nulled, and the spacecraft was then placed in the primary guidance automatic control mode to maintain attitude.

Guidance system performance was again nominal and there were no significant attitude excursions. The throttle profile was started in the idle position, then moved to 40 percent for 21 seconds, and finally to full throttle for the remainder of the firing. The maneuver residuals were 0.2, 0.0, and 0.3 ft/sec in the X, Y, and Z axes, respectively. The abort guidance system was powered up and was used to monitor both attitude and velocity change and agreed with primary system readouts throughout the maneuver.

8.9 TRANSEARTH COAST

8.9.1 Coast Phase Activities

To establish a passive thermal control mode during initial transearth coast, the spacecraft was manually maneuvered to the initial attitude by nulling out the attitude error needles. In this position, spacecraft rates were monitored by the ground. When rates were sufficiently damped, 21 yaw-right pulse inputs were made to establish a vehicle rolling motion. The resulting maneuver placed the apparent moon and earth motion horizontal with respect to the lunar module windows.

After the passive thermal control mode was established, the lunar module was powered down according to the contingency checklist for an emergency power-down. Minor modifications were made to this procedure to account for passive thermal control mode operation. The spacecraft functions remaining were low-bit-rate telemetry, S-band tracking and voice, caution and warning sensing, cabin repressurization capability, and the operation of the glycol pumps and suit fans.

A series of master alarms and battery caution lights was noted and isolated to descent-stage battery 2. In view of the equal distribution of the 12 amperes being supplied by all batteries in the powered down mode, reverse current was ruled out, and because of the low current load, overtemperature was also ruled out. Therefore, the problem was attributed to a sensor (discussed in section 14.2.3). To prevent recurring alarms, the master alarm circuit breaker was opened.

After the first descent propulsion maneuver, the ground provided a work/rest schedule which kept either the Commander or the Lunar Module Pilot on watch at all times. This schedule was followed at first with the command module being utilized as a sleeping area. However, after lunar module power-down, the command module cabin temperature decreased to the point that it was unacceptable for use as a rest station. Thereafter, all three crew members remained in the lunar module and any sleep was in the form of short naps. The lunar module also cooled down to an extent where sleep was not possible for approximately the last 16 hours.

The potable water available was used solely for drinking and rehydrating juices. No water was expended in rehydratable foods, since there was an ample supply of both prepared wetpacks and nonrehydratable foods (breads, brownies, food cubes, etc.).

It became apparent that there were insufficient lithium hydroxide cartridges in the lunar module to support the abort mission, even with allowable carbon dioxide levels extended to a partial pressure of 15 mm Hg. With ground instructions, a system was constructed which attached a command module lithium hydroxide cartridge to each of two lunar module suit hoses. The Commander's remaining hose was placed in the tunnel area to provide fresh oxygen to the command module, while the Lunar Module Pilot's remaining hose was positioned in the lunar module environmental control area. At a later time, a second cartridge was added in series to the cartridges initially installed, as shown in figure 6.7-1. In each case, the drop in carbon dioxide levels reported by the ground showed satisfactory operation of this improvised carbon dioxide removal system.

Earlier, at approximately 73 hours, the command module windows had become nearly opaque with water droplets. This moisture contamination continued to increase, and at approximately 110 hours a thin wafer film appeared on the interior command module structure itself, as well as on

the lunar module windows. Despite this condensation because of the reduced cabin temperature, at no time did the humidity reach levels which were uncomfortable to the crew. The moisture on the lunar module windows disappeared shortly after power-up at approximately 135 hours. The condensation generally disappeared after parachute deployment, although the structure remained cold even after landing.

After the command module auxiliary urine dump, used through the side hatch, was exercised, the crew was requested by the ground to inhibit all further overboard dumps so as not to interfere with navigation sightings. This single dump was noted to seriously degrade visibility through the command module hatch window. Since this restriction was never retracted, all subsequent urine collections were stowed onboard. The containers utilized for urine collections were the six lunar module urine transfer bags, three command module backup waste bags, the condensate container, two water collection bags for the portable life support system, and three urine collection devices. The command module waste stowage compartment appeared to be full with only seven focal bags stowed in this area. Adding to the waste stowage problem was the stiffness of the outer focal bags.

At approximately 105 hours, the crew performed a manual descent propulsion maneuver to improve the entry angle. Since the primary guidance and navigation system was powered down, alignment was accomplished manually. The spacecraft was maneuvered to place the cusps of the earth's terminator on the Y-axis reticle of the crewmen optical alignment sight. The illuminated portion of the earth was then placed at the top of the reticle. This procedure positioned the lunar module X-axis perpendicular to the earth's terminator and permitted a retrograde maneuver to be performed perpendicular to the flight path to steepen the entry angle. The proper pitch attitude was maintained by positioning the sun in the top center portion of the telescope. With the spacecraft in the proper attitude, a body-axis alignment using the abort guidance system was followed immediately by entry into an attitude hold mode. This sequence resulted in attitude indications of zero for all axes and permitted use of the attitude error needles to maintain attitude. Attitude control during the maneuver was performed by manually nulling the pitch and roll error needles. This maneuver necessarily required crew-cooperation, since the Lunar Module Pilot controlled pitch and the Commander controlled roll. Yaw attitude was maintained automatically by the abort guidance system. The Command Module Pilot called out the engine start and stop times, and the entire 14-second firing was performed at 10 percent thrust. The engine was shut down 1 second short of the calculated firing time to preclude an overburn which might require use of minus-X thrusters and cause plume impingement on the command module. The control and alignment techniques to accomplish such a contingency midcourse maneuver are believed to be satisfactory.

The passive thermal control mode was reestablished by rolling 90 degrees with reference to the abort-guidance-driven attitude displays. This maneuver placed the terminator parallel to the X-axis of the crewmen optical alignment sight. Rates were nulled in pitch and roll with the thrust/translation controller assembly. Yaw was again automatically controlled by the abort guidance system. Nulling rates to zero was impossible because of the inaccurate readout of the rate needles. When rates appeared to be nulled, yaw control was placed in the reaction control pulse mode. Twelve yaw-right pulses were then used to start the passive thermal control mode maneuver. Because rates could not be completely nulled, some roll-pitch coupling was observed.

At approximately 109 hours, the burst disk in the supercritical helium tank ruptured, as expected. The venting caused an unexpected reversal in the lunar module yaw rate [command module roll] during passive thermal control at about twice the initial value and also introduced some pitch motion. No attempt was made, however, to reestablish manually a stable passive thermal control mode.

8.9.2 Entry Preparation

The unprecedented powered-down state of the command module required generation of several new procedures in preparation for entry. The command module was briefly powered up to assess the operation of critical systems using both onboard and telemetered instrumentation. Any required power in the command module had been supplied during transearth coast from the lunar module through the umbilical connectors. It was through this means that the entry batteries were fully charged, with battery A requiring 15 hours and battery B approximately 3 hours. While these procedures represented a radical departure from normal operation, all were understandable and easily accomplished to achieve the desired system readiness.

Equipment transfer and stowage in both the command module and lunar module was completed about 7 hours prior to entry, with the exception of the cameras that were to be used for service module photography. At 6-1/2 hours before entry, command module activity included powering up the instrumentation and placing entry battery C on main bus A, with main bus B still powered from the lunar module. The command module reaction control thrusters were preheated for 20 minutes, and all instrumented engines were observed to be above the minimum operating temperature 10 minutes after heater operation was terminated.

8.9.3 Final Midcourse Correction

Lunar module powerup for the final midcourse correction maneuver was performed according to the prescribed contingency checklist, with only minor deviations furnished by the ground. Shortly afterward, the lunar module windows cleared of moisture and the cabin temperature again became comfortable. Approximately 6 hours before entry, the passive thermal control mode was terminated and the spacecraft was maneuvered to place the earth in the crewmen optical alignment sight with the terminator parallel to the Y axis in preparation for the midcourse maneuver. At that time, a sun/moon alignment was made. Acquisition of these bodies was made by pitching up in a plane roughly parallel to the ecliptic plane. The sun filter made viewing through the telescope reticle very difficult. The spacecraft was controlled by the Lunar Module Pilot from commands given by the Commander, who responded when the reticle lines bisected the moon and solar disks. Three sets of marks were taken on each body. The initial maneuver to the firing attitude for the final midcourse correction was done manually using the earth as a reference in the same manner as the previous maneuver. This procedure presented no problems, even though the earth disk was considerably larger at this time.

With primary guidance available, guidance system steering was manually followed to trim the spacecraft attitudes for the maneuver. Although the displayed attitudes looked favorable in comparison to ground-supplied and out-the-window readings, the primary guidance steering needles read full scale left in roll and yaw (section 6.4). At about 137 hours 40 minutes, the lunar module reaction control system was used to provide a 2.9-ft/sec velocity correction. The maneuver was completed using manual pitch and roll control and abort guidance yaw control in a manner similar to that for the previous midcourse correction.

8.9.4 Service Module Separation and Photography

Following the lunar module maneuver to the service module separation attitude, the command module platform heaters were activated, the command module reaction control system was pressurized, and each individual thruster was fired. An abort guidance attitude reference was provided with all zeros displayed on the attitude error needles. The lunar module was placed in an attitude hold mode using the abort guidance system; X-axis translation was monitored on the displays. After the reaction control system check was completed, the Commander conducted a plus-X translation maneuver of 0.5 ft/sec, followed immediately by service module jettison. The pyro activation was heard and a minus 0.5-ft/sec translation maneuver was immediately commenced to remove the previously added velocity and preclude service module recontact. The jettison dynamics caused the undocked vehicles to pitch down about 10 degrees. Control was then switched to primary guidance minimum impulse, and a pitchup maneuver was started to

sight the service module in the docking window. The lightened spacecraft combination was easily maneuvered using attitude control in both the manual minimum-impulse and automatic attitude-hold modes.

The service module first appeared in the docking window at a distance of about 80 feet. The entire bay 4 outer panel was missing, and torn Mylar insulation was seen protruding from the bay. Because of the brilliant reflections from the Mylar, it was difficult to see or photograph any details inside the bay. Initial photography of the service module was conducted through the docking window using the command module 70-mm camera and an 80-mm lens. This camera, the 16-mm sequence camera with a 75-mm lens, and the command module electric still camera with a 250-mm lens were then operated while viewing through the right-hand window. Camera settings were made according to ground instructions. No magazine designation was made by the ground for the sequence camera, so the surface color film was used.

Upon completion of photography, the two docked vehicles were maneuvered back to the service module separation attitude in preparation for the command module alignment. Star observation through the command module optics in this attitude was poor because of light reflecting from the lunar module, and the Commander varied the pitch attitude by approximately 20 degrees in an attempt to improve star visibility. These attitude excursions, however, were not effective, and the spacecraft was returned to the original separation attitude for the command module alignment.

8.9.5 Command Module Activation

At 2-1/2 hours prior to entry, the command module was fully powered up and lunar module power transfer was terminated. After command module computer activation, the unfavorable spacecraft attitude delayed communications signal lockup and the ensuing ground uplink commands. The stable platform was coarse aligned to ground-supplied reference angles, and an optical fine alignment made using two stars. Particles venting from the command module umbilical area impeded command module optics operation. With the lunar module attached to the command module and the command module optics pointed away from the sun, individual stars were barely visible through the optics. Also sun reflections from the lunar module sublimator and the nearest reaction control quad prevented positive identification of constellations.

8.9.6 Lunar Module Undocking

The maneuver to the undocking attitude was made by the lunar module. Time consuming operations were followed to avoid gimbal lock of both spacecraft platforms. Because of the difference in alignments between the two

spacecraft, considerable difficulty was encountered in maneuvering to the lunar module undocking attitude without driving the command module platform into gimbal lock. The maneuver required a complicated procedure using the lunar module platform and close cooperation between the Commander and Command Module Pilot. The resulting maneuver also used up considerable lunar module reaction control fuel. The final undocking attitude was very close to command module gimbal lock attitude. A different command module alignment procedure should have been used to prevent the probability of gimbal lock.

Hatch closeout in both spacecraft was normal, and a successful command module hatch integrity check was made, with a differential pressure of 3.4 psi. The command module environmental control and autopilot systems were activated, and the lunar module was undocked 1 hour before entry. Lunar module jettison was slightly louder than service module jettison and the lunar module was stable as it translated away using only tunnel pressure. While controllable by a single reaction control engine pulse, there was a continuous pitch-up torque on the command module which persisted until entry.

8.10 ENTRY AND LANDING

The entry attitude and platform alignment were confirmed by a successful sextant star check and moon occultation within 1 second of the predicted time. The pre-entry check and initialization of the entry monitor system were normal. However, entry monitor system operation was initiated manually when the 0.05g light remained off 3 seconds after the actual 0.05g time (as discussed in section 14.1.5.). In addition, the entry monitor system trace was unexpectedly narrow and required excessive concentration to read. The guided entry was normal in all respects and was characterized by smooth control inputs. The first acceleration peak reached approximately 5g.

Landing decelerations were mild in comparison to Apollo 8, and the spacecraft remained in the stable I flotation attitude after parachute release. Recovery proceeded rapidly and efficiently. Standard Navy life vests were passed to the crew by recovery personnel. For ease of donning and egress, these are preferable to the standard underarm flotation equipment. They would also quite effectively keep an unconscious crewman's head out of the water.

9.0 BIOMEDICAL EVALUATION

This section is a summary of Apollo 13 medical findings, based on preliminary analyses of biomedical data. From the medical point of view, the first 2 days of the Apollo 13 mission were completely routine. The biomedical data were excellent, and physiological parameters remained within expected ranges. Daily crew status reports indicated that the crewmen were obtaining adequate sleep, no medications were taken, and the radiation dosage was exactly as predicted.

9.1 BIOINSTRUMENTATION AND PHYSIOLOGICAL DATA

The biomedical data were excellent in quality during the period from launch to the occurrence of the inflight incident. Physiological data for the remainder of the mission were very scant. The command module was completely powered down, and this eliminated simultaneous biomedical monitoring capability. In the lunar module, only one electrocardiogram signal for one crewman at a time can be monitored. However, even these medical data were sacrificed to improve air-to-ground communications.

Prior to the abort condition, physiological parameters were well within expected ranges. Just prior to the incident, heart and respiratory rates of the crewmen were as follows.

Crewman	Heart rate, beats/min	Respiratory rate, breaths/min
Commander	68	18
Command Module Pilot	65	15
Lunar Module Pilot	72	12

At 55:54:54, a telemetry dropout was observed. Immediately after the incident, crew heart rates ranged from 105 to 136 beats/min. These heart rates are well within normal limits and are indicative of stress and an increased workload.

During the entry phase, biomedical data on the Command Module Pilot and Lunar Module Pilot were available. The Command Module Pilot's heart rate ranged from 60 to 70 beats/min. The Lunar Module Pilot's heart rate ranged from 100 to 125 beats/min, which in contrast to his basal rate was

an indication of an inflight illness detected after flight. The Commander had removed his bioharness shortly after the emergency incident; hence, no biomedical data were available from him during the entry.

9.2 INFLIGHT HISTORY

9.2.1 Adaptation to Weightlessness

The Commander and the Command Module Pilot both reported a feeling of fullness in the head lasting for several hours on the first day of the mission. The Lunar Module Pilot reported a similar feeling and also that he felt like he was "hanging upside down." The Commander reported that all crewmen had red eyes the first day of the mission.

Upon awakening on the second day of the mission, the Lunar Module Pilot complained of a severe headache. He took two aspirin, ate breakfast, and became immediately engaged in unrestrained physical activity. He then became nauseated, vomited once, and lay down for several hours. He then experienced no further nausea. The Lunar Module Pilot continued to take two aspirin every 6 hours to prevent recurrence of the headache. After the inflight incident, he took aspirin on only one occasion.

9.2.2 Cabin Environment

The major medical concern, recognized immediately after the abort decision, was the possibility of carbon dioxide buildup in the lunar module atmosphere. Since the physiological effects of increased carbon dioxide concentration are well known and readily recognizable with proper biomedical monitoring, the allowable limit of carbon dioxide buildup was increased from the nominal 7.6 to 15mm Hg. The carbon dioxide level was above 7.6mm Hg for only a 4-hour period, and no adverse physiological effects or degradation in crew performance resulted from this elevated concentration. Modified use of the lithium hydroxide cartridges (section 6.7) maintained the carbon dioxide partial pressure well below 1mm Hg for the remainder of the flight.

9.2.3 Sleep

The crew reported sleeping well the first 2 days of the mission. They all slept about 5-1/2 hours during the first sleep period. During the second period, the Commander, Command Module Pilot, and Lunar Module Pilot slept 5, 6, and 9 hours, respectively. The third sleep period was scheduled for 61 hours, but the oxygen tank incident at 56 hours precluded sleep by any of the crew until approximately 80 hours.

After the incident, the command module was used as sleeping quarters until the cabin temperature became too cold. The crew then attempted to sleep in the lunar module or the docking tunnel, but the temperature in these areas also dropped too low for prolonged, sound sleep. In addition, coolant pump noise from the lunar module and frequent communications with the ground further hindered sleep. The total sleep obtained by each crewman during the remainder of the mission after the incident is estimated to have been 11, 12, and 19 hours for the Commander, Command Module Pilot, and Lunar Module Pilot, respectively.

9.2.4 Water

Preflight testing of both command module and lunar module water supplies revealed no significant contaminants. The nickel content from samples taken at the command module hot water port was 0.05 mg/l. Elevated nickel concentration has been a consistent finding in previous missions and has been ruled acceptable in view of no detrimental effects on crew physiology. There was a substantial buildup in total bacterial count from the time of final filling of the command module potable water system until final preflight sampling 24 hours prior to launch. This count was deemed acceptable under the assumption the first inflight chlorination would reduce the bacterial population to specification levels. Preflight procedures will be reviewed to investigate methods of preventing growth of organisms in the command module water system during the countdown phase. The inflight chlorination schedule was followed prior to the incident, after which the potable water was not chlorinated again.

The crew rationed water and used it sparingly after the oxygen tank incident. Not more than 24 ounces of water were consumed by each crewman after the incident. The crew reported that the juice bags contained about 20 percent gas, but that this amount was not enough to cause any distress.

9.2.5 Food

The flight menus were similar to those of prior Apollo missions and were designed to provide approximately 2100 kilocalories per man per day. The menus were selected on the basis of crew preferences determined by preflight evaluation of representative flight foods. There were no modifications to the menu as a result of the late crew change. New food items for this mission included meatballs with sauce, cranberry-orange relish, chicken and rice soup, pecans, natural orange juice crystals, peanut butter, and jelly. Mustard and tomato catsup were also provided for the sandwiches.

The crew followed the flight menus prior to the inflight incident and maintained a complete log of foods consumed. To conserve water during the abort phase, the crew consumed only those foods which did not require water for rehydration. The crew drank juices in preference to plain water to help maintain their electrolyte balance.

The crew's comments about the quality of the food were generally favorable, but they reported that food packaging and stowage could be improved. The crew encountered some difficulty in removing the meal packages from the lower equipment bay food container and in replacing some uneaten food items. Preflight briefings of future crews should alleviate these difficulties.

Syneresis, or separation of a liquid from a solid, occurred in some of the canned sandwich spreads, particularly the ham salad. The free liquid escaped when the can was opened, and the salad was too dry to spread. The crew commented on the positive pressure in the bread packages, which was expected since there was only a slight vacuum on these packages. Any additional vacuum would compress the bread to an unacceptable state, and if the packages were punctured, the bread would become dry and hard. The crew recommended a change which has been implemented wherein Velcro patches will be attached to the bread, mustard, and catsup packages.

9.2.6 Radiation

The personal radiation dosimeters were inadvertently stowed in the pockets of the crewmen's suits shortly after lift-off. The Command Module Pilot's dosimeter was unstowed at 23 hours and was hung under the command and service module optics for the remainder of the mission. The final reading from this dosimeter yielded a net integrated (uncorrected) dose of 410 mrad. The other two dosimeters yielded net doses of 290 and 340 mrad.

The Van Allen belt dosimeter registered a maximum skin dose rate of 2.27 rad/hr and a maximum depth dose rate of 1.35 rad/hr while ascending through the belt at about 3 hours. Dose rates during descending belt passage and total integrated doses were not obtained because of command module power-down and later, by the absence of high-bit-rate telemetry during the entry phase.

The crewmen were examined by total body gamma spectroscopy 30 days before flight and 6 and 16 days after recovery. Analyses of the gamma spectrum data for each crewman revealed no induced radioactivity. However, the analyses did show a significant decrease in total body potassium (K^{40}) for each crewman as compared to preflight values. Total body potassium values determined on the second postflight examination had returned to preflight values for each crewman.

The absorbed dose from ionizing radiation was approximately 250 mrad, which is well below the threshold of detectable medical effects. The crew-absorbed dose from the neutron component of the SNAP-27 (part of experiment package) radiation cannot be determined quantitatively at this time. Preliminary evaluations indicated that it was also well below the threshold of detectable medical effects.

9.2.7 Medications

The crew attempted to use the Afrin spray bottles but reported they were unable to obtain sufficient spray, as discussed in section 14.3.3. The crew also reported that the thermometer in the medical kit did not register within scale. Postflight analysis of the medical kit has shown that the thermometer operates properly and a procedural error resulted in the failure to obtain a correct oral temperature inflight. Medications used by each of the crewmen are shown in the following table:

Crewman	Medication	Time of use
Commander	1 Aspirin 1 Dexedrine	Unknown 2 or 3 hours prior to entry
Command Module Pilot	1 Lomotil 2 Aspirin 1 Dexedrine-Hyoscine	After 98 hours Unknown 1 or 2 hours prior to entry
Lunar Module Pilot	2 Aspirin every 6 hours 1 Dexedrine-Hyoscine	Second mission day until the incident 1 or 2 hours prior to entry

9.2.8 Visual Phenomena

The crew reported seeing point flashes or streaks of light, as had been previously observed by the Apollo 11 and 12 crews. The crewmen were aware of these flashes only when relaxed, in the dark, and with their eyes closed. They described the flashes as "pinpoint novas," "roman candles," and "similar to traces in a cloud chamber." More point flashes than streaks were observed, and the color was always white. Estimates of the frequency ranged from 4 flashes per hour to 2 flashes per minute.

9.3 PHYSICAL EXAMINATIONS

Preflight physical examinations of both the primary and backup crews were conducted 30 days prior to launch, and examinations of the primary crew only were conducted 15 and 5 days prior to launch. The Lunar Module Pilot suffered a sore throat 18 days before launch, and throat swabs from all three crewmen were cultured on two occasions. Since the organism identified was not considered pathogenic and the crew showed no symptoms of illness, no treatment was necessary.

Eight days before flight, the primary Command Module Pilot was exposed to rubella (German measles) by a member of the backup crew. The physical examination 5 days before flight was normal, but laboratory studies revealed that the primary Command Module Pilot had no immunity to rubella. Consequently, on the day prior to launch the final decision was made to replace the primary Command Module Pilot with the backup Command Module Pilot. A complete physical examination had been conducted on the backup Command Module Pilot 3 days before flight, and no significant findings were present in any preflight histories or examinations.

Postflight physical examinations were conducted immediately after recovery. These physical examinations were normal, although all crewmen were extremely fatigued and the Lunar Module Pilot had a urinary tract infection. While standing during portions of his postflight physical examination, the Lunar Module Pilot had several episodes of dizziness, which were attributed to fatigue, the effects of weightlessness, and the urinary tract infection. The Commander, Command Module Pilot, and Lunar Module Pilot exhibited weight losses of 14, 11, and 6.5 pounds, respectively. In the final 4 or 5 hours of the flight, the Lunar Module Pilot drank considerably more water than did the other crewmen and possibly replenished his earlier body fluid losses.

The Command Module Pilot had a slight irritation at the site of the superior sensor on the upper chest, but the Commander and Lunar Module Pilot had no irritation at any sensor sites.

10.0 MISSION SUPPORT PERFORMANCE

10.1 FLIGHT CONTROL

The operational support provided by the flight control team was satisfactory and timely in safely returning the Apollo 13 crew. Only the inflight problems which influenced flight control operation and their resultant effects on the flight plan are discussed.

Prior to launch, the supercritical helium pressure in the lunar module descent propulsion system increased at an abnormally high rate. After cold soak and venting, the rise rate was considered acceptable for launch. At 56 hours during the first entry into the lunar module, the rise rate and pressure were reported to be satisfactory; therefore, a special venting procedure was not required.

A master caution and warning alarm at 38 hours indicated the hydrogen tank pressures were low. As a result, it was planned to use the cryogenic tank fans more often than scheduled to provide a more even distribution of fluid and to stabilize heat and pressure rise rates.

The two tanks containing cryogenic oxygen, used for fuel cell operation and crew breathing, experienced a problem at about 56 hours, as described in section 14.1.1 and reference 1. This condition resulted in the following flight control decisions:

- a. Abort the primary mission and attempt a safe return to earth as rapidly as possible.
- b. Shut down all command and service module systems to conserve consumables for entry.
- c. Use the lunar module for life support and any propulsive maneuvers.

Powering down of the command and service modules and powering up of the lunar module were completed at 58:40:00. The optimum plan for a safe and quick return required an immediate descent engine firing to a free-return circumlunar trajectory, with a pericyynthion-plus-2-hour maneuver (transearth injection) to expedite the landing to about 142:30:00. Two other midcourse corrections were performed, the first using the descent engine. Only essential life support, navigation, instrumentation, and communication systems were operated to maximize electrical power and cooling water margins. Detailed monitoring of all consumables was continuously maintained to assess these margins, and the crew was always

advised of their consumables status. A procedure was developed on the ground and used by the crew to allow use of command module lithium hydroxide cartridges for carbon dioxide removal in the lunar module environmental control system (see section 6.8). The passive thermal control mode was established using the lunar module reaction control system and was satisfactorily maintained throughout transearth coast.

A major flight control function, in addition to the monitoring of systems status and maintaining of consumable quantities above red-line values, was to determine the procedures to be used immediately prior to and during entry. After satisfactory procedures were established, they were verified in a simulator prior to advising the crew. These procedures called for first separating the service module, remaining on lunar module environmental control and power as late as possible, coaligning the two platforms, and separating the lunar module using tunnel pressure. The command module tunnel hatch was installed and a leak check was performed prior to lunar module undocking, which occurred about 1 hour before entry. All spacecraft operations were normal from undocking through landing, which occurred very close to the established target.

10.2 NETWORK

The Mission Control Center and the Manned Space Flight Network provided excellent support throughout this aborted mission. Minor problems occurred at different sites around the network, but all were corrected with no consequence to flight control support. Momentary data losses occurred seven different times as a result of power amplifier faults, computer processor executive buffer depletion, or wave guide faults. On each occasion, data lock-up was regained in just a few minutes.

10.3 RECOVERY OPERATIONS

The Department of Defense provided recovery support commensurate with mission planning for Apollo 13. Because of the emergency which resulted in premature termination of the mission, additional support was provided by the Department of Defense and offers of assistance were made by many foreign nations, including England, France, Greece, Spain, Germany, Uruguay, Brazil, Kenya, the Netherlands, Nationalist China, and the Soviet Union. As a result of this voluntary support, a total of 21 ships and 17 aircraft were available for supporting an Indian Ocean landing, and 51 ships and 21 aircraft for an Atlantic Ocean landing. In the Pacific Ocean, there were 13 ships and 17 aircraft known to be available over and above the forces designated for primary recovery support.

Support for the primary recovery area consisted of the prime recovery ship, USS Iwo Jima, five helicopters from the Iwo Jima, and two HC-130H rescue aircraft. Later, the experimental mine sweeper, USS Granville Hall, and two HC-130H aircraft were added to the end-of-mission array. One of the helicopters, designated "Recovery," carried the flight surgeon, and was utilized for retrieval of the crew. Two of the helicopters, designated "Swim 1" and "Swim 2," carried swimmers and the necessary recovery equipment. A fourth helicopter, designated "Photo" was used as a photographic platform, and the fifth helicopter, designated "Relay," served as a communications relay aircraft. The four aircraft, designated "Samoa Rescue 1, 2, 3, and 4," were positioned to track the command module after exit from blackout, as well as to provide pararescue capability had the command module landed uprange or downrange of the target point. The USS Granville Hall was positioned to provide support in the event that a constant-g (backup) entry had to be flown. Table 10.3-I lists all the dedicated recovery forces for the Apollo 13 mission.

TABLE 10.3-I.- RECOVERY SUPPORT

Landing area	Support ^B		Remarks
	Number	Unit	
Launch site	1	LCU	Landing craft utility (landing craft with command module retrieval capability) - USS Paiute
	1	HH-3E	Helicopter with para-rescue team staged from Patrick AFB, Florida
	2	HH-53C	Helicopters capable of lifting the command module; each with para-rescue team staged from Patrick AFB, Florida
	1	ATF	
	2	SH-3	Helicopters staged from Norfolk NAS, Virginia
Launch abort	1	DD	USS New
	3	HC-130H	Fixed wing aircraft; one each staged from McCoy AFB, Florida; Pease APB, New Mexico; and Lajes APB, Azores
Earth orbit	2	DD	USS New
	2	HC-130H	Fixed wing aircraft staged from Ascension
Primary end-of-mission, Mid-Pacific earth orbital, and deep-space secondary	1	LPH	USS Iwo Jima
	1	DD	USS Benjamin Stoddert
	3	SH-3D	Helicopters staged from USS Iwo Jima
	2	HC-130H	Fixed wing aircraft staged from Hickam AFB, Hawaii

^BTotal ship support = 5
Total aircraft support = 23

10.3.1 Command Module Location and Retrieval

The Iwo Jima's position was established accurately using a satellite navigation system. A navigation fix was obtained at 1814 G.m.t., April 17, 1970, and the position of the ship at spacecraft landing was dead-reckoned back to the time of landing and determined to be 21 degrees 34.7 minutes south latitude and 165 degrees 23.2 minutes west longitude. At landing a radar range of 8000 yards and a visual bearing of 158.9 degrees east of north (true heading) were obtained from which the command module landing point was determined to be 21 degrees 38 minutes 24 seconds south latitude and 165 degrees 21 minutes 42 seconds west longitude. This position is judged to be accurate to within 500 yards.

The ship-based aircraft were deployed relative to the Iwo Jima and were on station 20 minutes prior to landing. They departed station to commence recovery activities upon receiving notice of visual contact with the descending command module. Figure 10.3-1 depicts an approximation of the recovery force positions just prior to the sighting of the command module.

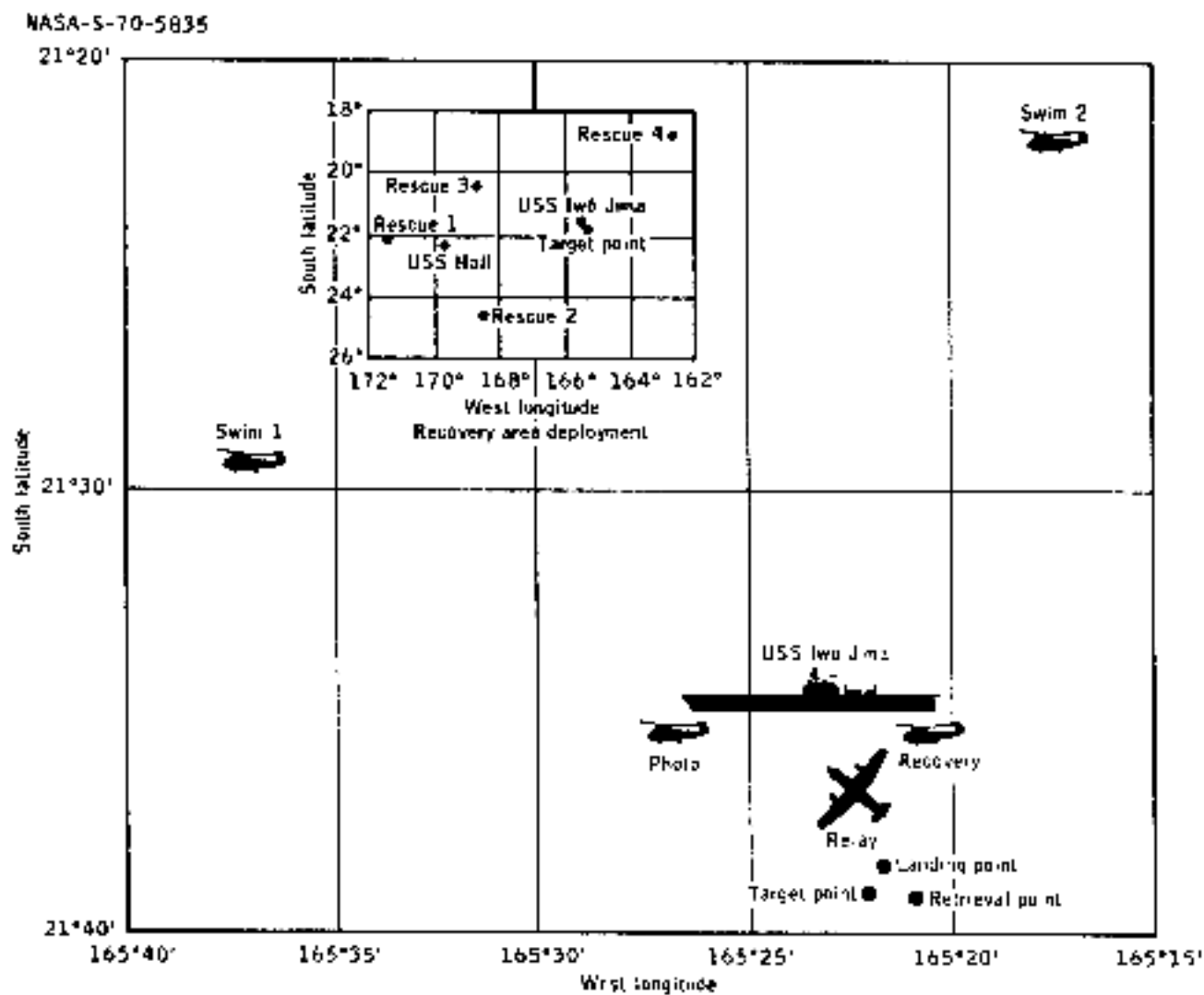

Figure 10.3-1.- Recovery support at earth landing.

The first reported electronic contact by the recovery forces was through S-band contact by Samoa Rescue 4. A visual sighting report by the Recovery helicopter was received and was followed shortly thereafter by acquisition of the recovery beacon signal by the Recovery, Photo, and Swim 1 helicopters. Fuel dump was noted and voice contact was made with the descending spacecraft, although no latitude and longitude data were received. The command module landed at 1807 G.m.t. and remained in the stable 1 flotation attitude. The flashing light was operating and the inflation of the uprighting system commenced about 10 minutes subsequent to landing.

After confirming the integrity of the command module and the status of the crew, the Recovery helicopter crew attempted to recover the main parachutes with grappling hooks and flotation gear prior to their sinking. Swim 1 and Swim 2 helicopters arrived on scene and immediately proceeded with retrieval. Swim 2 deployed swimmers to provide flotation to the spacecraft, and Swim 1 deployed swimmers to retrieve the apex cover, which was located upwind of the spacecraft. The flight crew was onboard the recovery helicopter 7 minutes after they had egressed the command module, and they arrived aboard Iwo Jima at 1853 G.m.t.

Command module retrieval took place at 21 degrees 39.1 minutes south latitude and 165 degrees 20.9 minutes west longitude at 1936 G.m.t. One main parachute and the apex cover were retrieved by small boat and brought aboard.

The flight crew remained aboard the Iwo Jima overnight and were flown to Pago Pago, Samoa, the following morning. A C-141 aircraft then took the crew to Hawaii, and following a ceremony and an overnight stay, they were returned to Houston.

Upon arrival of the Iwo Jima in Hawaii, the command module was off-loaded and taken to Hickam Air Force Base for deactivation. Two and one half days later, the command module was flown to the manufacturer's plant at Downey, California aboard a C-133 aircraft.

The following is a chronological listing of events during the recovery operations.

Event	Time, G.m.t.
	<u>April 17, 1970</u>
S-band contact by Samoa Rescue 4	1801
Visual contact by Swim 2	1802
VHF recovery beacon contact by Recovery/Swim 1 helicopters	
Voice contact by Recovery helicopter	1803
Visual contact by Relay/Recovery helicopters/ Iwo Jima	1803
Command module landed, remained in stable I	1807
Swimmers deployed to retrieve main parachutes	1809
First swimmer deployed to command module	1816
Flotation collar inflated	1824
Life preserver unit delivered to lead swimmer	1831
Command module hatch opened	1832
Helicopter pickup of flight crew completed	1842
Recovery helicopter on board Iwo Jima	1853
Command module secured aboard Iwo Jima	1936
	<u>April 18</u>
Flight crew departed Iwo Jima	1820
	<u>April 20</u>
Flight crew arrival in Houston	0330
	<u>April 24</u>
Iwo Jima arrival in Hawaii	1930
	<u>April 25</u>
Safing of command module pyrotechnics completed	0235
	<u>April 26</u>
Deactivation of the fuel and oxidizer completed	1928
	<u>April 27</u>
Command module delivered to Downey, California	1400

10.3.2 Postrecovery Inspection

Although the standard format was followed during the deactivation and postrecovery inspection of the command module, it should be noted that extreme caution was taken during these operations to insure the integrity of the command module for postflight evaluation of the anomaly. After deactivation, the command module was secured and guarded.

The following discrepancies were noted during the postrecovery inspection:

- a. Some of the radioluminescent disks were broken.
- b. The apex cover was broken on the extravehicular handle side.
- c. The docking ring was burned and broken.
- d. The right-hand roll thruster was blistered.
- e. A yellowish/tan film existed on the outside of the hatch window, left and right rendezvous windows, and the right-hand window.
- f. The interior surfaces of the command module were very damp and cold, assumed to be condensation; there was no pooling of water on the floor.
- g. Water samples could not be taken from the spacecraft tanks (discussed in section 5.8).
- h. The postlanding ventilation exhaust valve was open and the inlet valve was closed; the postlanding ventilation valve unlock handle was apparently jammed between the lock and unlock positions (section 14.1.2).
- i. There was more and deeper heat streaking in the area of the compression and shear pads than has been normally observed.

11.C EXPERIMENTS

11.1 ATMOSPHERIC ELECTRICAL PHENOMENA

As a result of the electrical disturbances experienced during the Apollo 12 launch, the value of further research in this area was recognized and several experiments were performed prior to and during the Apollo 13 launch to study certain aspects of launch-phase electrical phenomena. The separate experiments consisted of measurements of the atmospheric electric field, low-frequency and very-low-frequency radio noise, the air/earth current density, and the electrical current flowing in the earth's surface, all of which result from perturbations generated by the launch vehicle and its exhaust plume. The analysis of the Apollo 12 lightning incident is reported in reference 3.

11.1.1 Electric Field Measurements

As shown in figures 11.1-1 and 11.1-2, a network of nine calibrated electric field meters was installed in the area to the north and west of the launch site. Seven of the field meters were connected to multiple channel recorders so that any excursions of the electric field intensity could be measured over a wide range of values. A special device was operated at site 5, located on the beach 4 miles northwest of the launch site. This device was installed to measure rapid changes in the electric field and was used, together with a sferics detector, to sense the electromagnetic radiation generated by lightning or other significant electrical discharges.

Illustrative data from the field instruments during launch are shown in figure 11.1-3. Very large perturbations of the normal electric field were recorded on meters at sites 1, 2, and 3 located near the launch tower. First, there was a rapid increase in the positive direction, followed by a slower negative decrease. Data taken at site 4, however, did not indicate any significant variations in field intensity. Excellent records at several sensitivity levels were obtained at site 7. The field perturbation immediately following launch rose to a maximum of 1200 volts/meter in about 25 seconds. The direction of field change then reversed, and a negative peak of some 300 volts/meter was reached in about 115 seconds. Thereafter, the field gradually returned to the unperturbed value.

At site 6, the record was similar to that for site 7 with an initial positive excursion followed by a slower negative change. At this station, however, there were large fluctuations superimposed on the record, as shown in figure 11.1-3(b). These fluctuations could have been caused by

NASA-S-70-5836

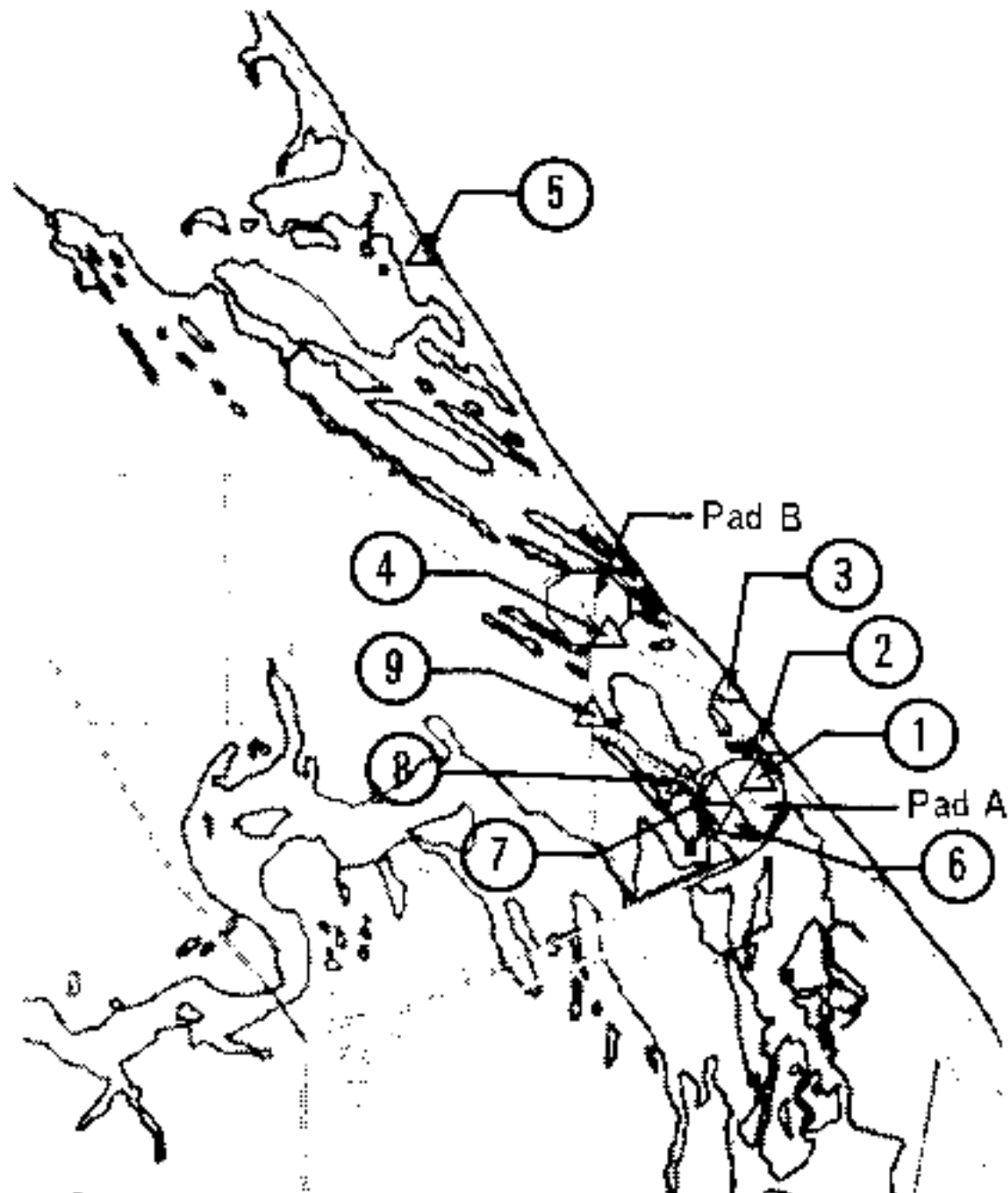

New Mexico Tech		Stanford Research Institute	
Field mill no.	Distance from vehicle, ft	Field mill no.	Distance from vehicle, ft
1	1360	6	1310
2	2400	7	1250
3	4920	8	2600
4	7220	9	5740
5	23 700		

Figure 11.1-1.- Field meter location in the launch site area.

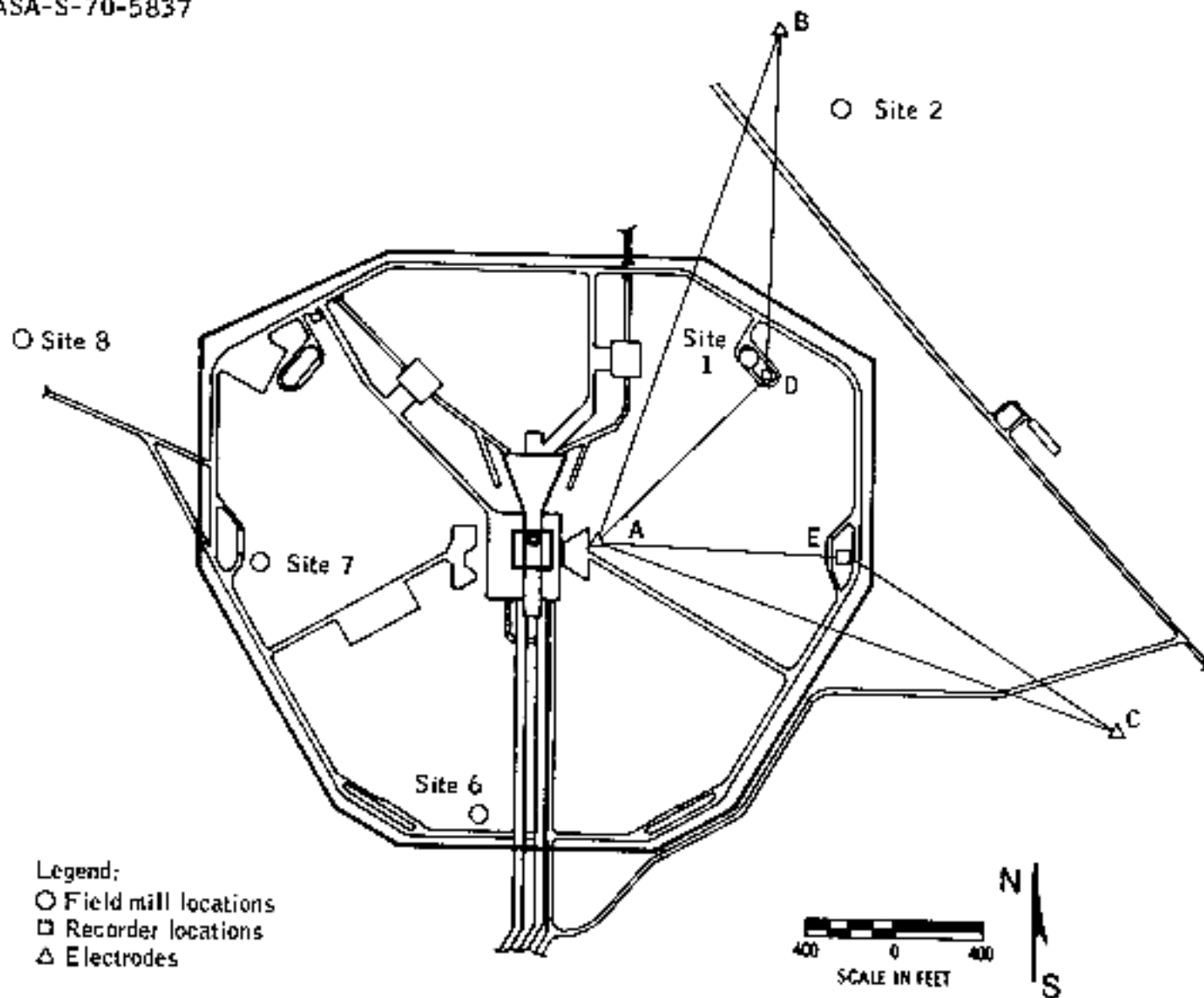
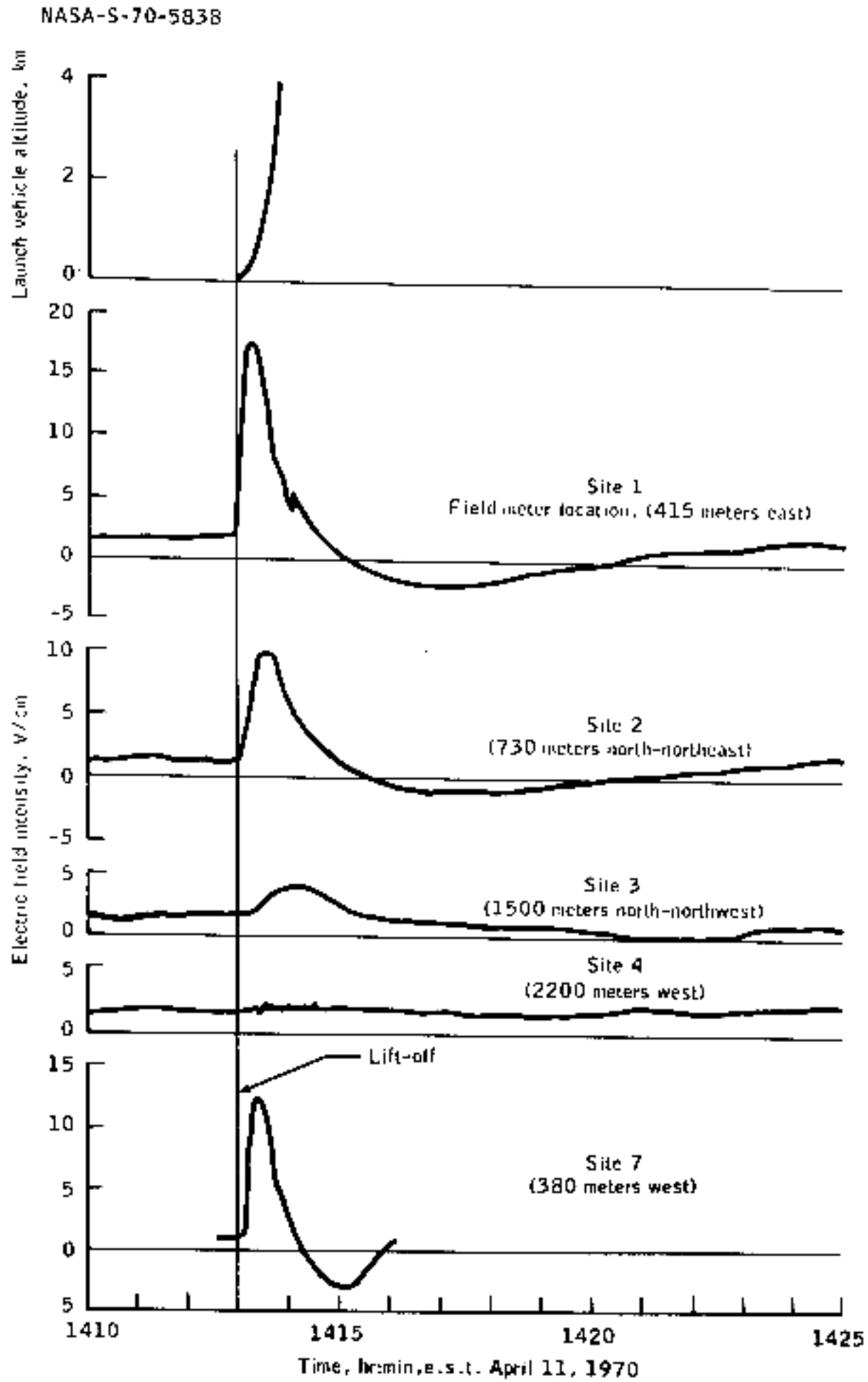

Figure 11.1-2.- Field meter locations in the proximity of the launch complex.

gravel and dust stirred up by the exhaust of the launch vehicle engine. After launch, a quantity of such debris was found near the surface of the field meter and its surrounding area. After the oscillations had subsided at T plus 40 seconds, there was a large negative field of approximately minus 3000 volts/meter which probably resulted from the exhaust and steam clouds that tended to remain over site 6.

Because of access restrictions to sites 8 and 9, the corresponding recorders were started several hours prior to launch and unfortunately had stopped before lift-off. However, substantial positive and negative field perturbations found on the stationary parts of the records were greater than anything found on the moving portion. Comparison of these records with those from sites 6 and 7 confirmed that the only large field perturbations were those accompanying launch. Consequently, the peak excursions of the records at sites 8 and 9 could be confidently associated with the maximum field perturbations occurring just after lift-off.



(a) Sites 1 to 4 and 7.

Figure 11.1-3.- Electrical discharge data for the Apollo 13 launch.

NASA-S-70-5839

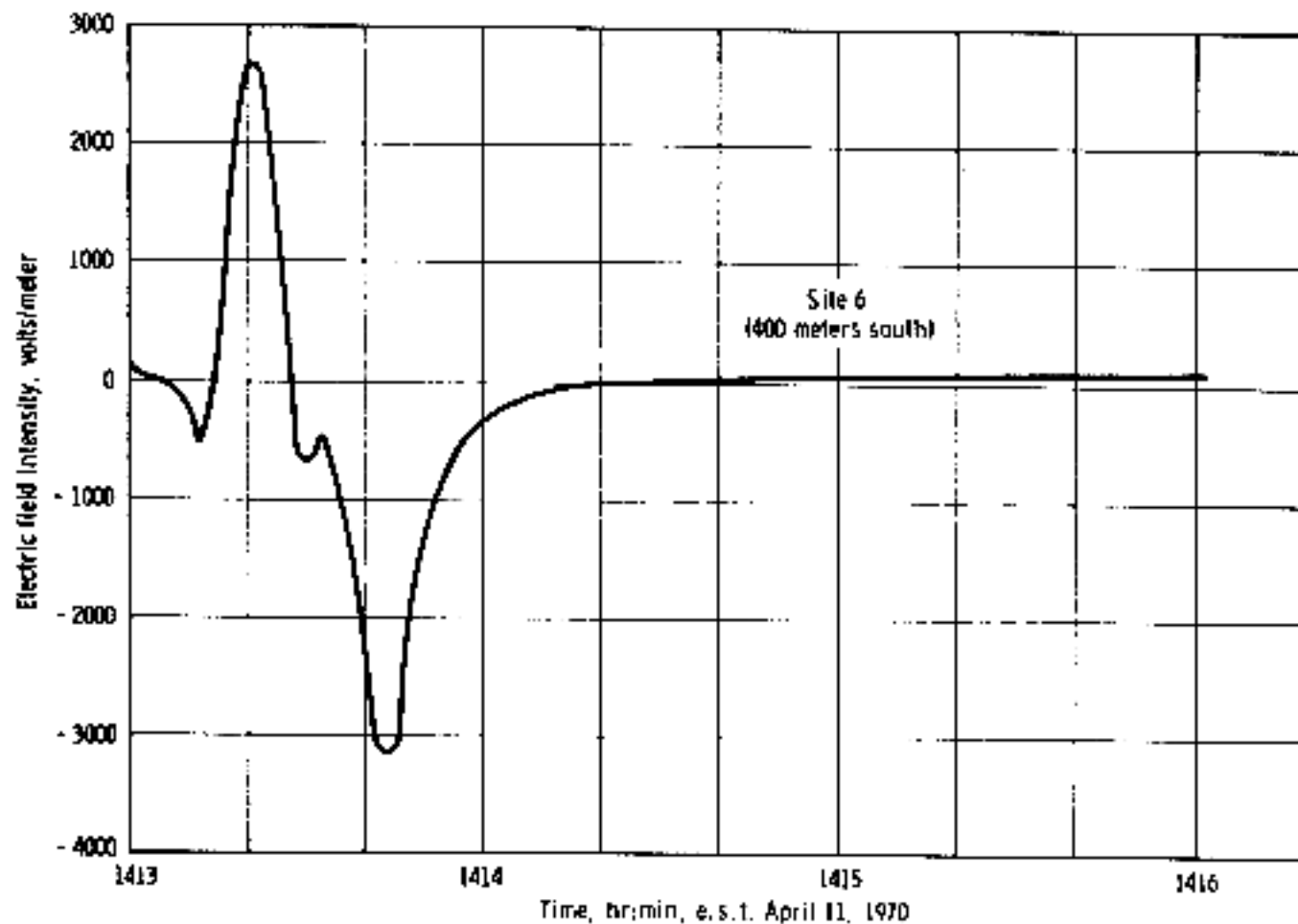

(b) Site 6.

Figure 11.1-3.- Concluded

No significant perturbation in the electric field was produced by the launch cloud at stations 4 or 5, although small-scale fluctuations, apparently resulting from vibrations, can be seen on the records of the fine weather field at both stations.

The field-change and sferics detectors at site 5 gave no indication of any lightning-like discharge during launch, although sporadic signals were later recorded during the afternoon of launch day. These signals probably came from lightning in a cold front which was stalled some distance to the northwest of the launch site and which passed over the launch site on April 12.

The above field meter records indicate the launch of the Apollo 13 vehicle produced a significant separation of electrical charge which could possibly increase the hazard in an otherwise marginal weather situation. At the present time the location and amount of the charge on the vehicle or exhaust clouds or a combination thereof are not well understood.

It is known that the electrostatic potentials develop on jet aircraft. These are caused by an engine charging current, which is balanced by a corona current loss from the aircraft. For a conventional jet aircraft, the equilibrium potential can approach a million volts. For the Saturn V launch vehicle, the charging current may be larger than that of a jet aircraft, and therefore, the equilibrium potential for the Saturn vehicle might be on the order of a million volts or more.

11.1.2 Very-Low and Low-Frequency Radio Noise

To monitor the low-frequency radio noise, a broad-band antenna system was used at site 7 to feed five receivers, tuned respectively to 1.5 kHz, 6 kHz, 27 kHz, 51 kHz, and 120 kHz.

During launch, a sudden onset of radio noise was observed almost coincidentally with the start of the electric field perturbation. This onset was very well marked on all but the 1.5 kHz channel. Following onset, the noise levels at 120 and at 51 kHz tended to decrease slowly in intensity for some 20 seconds. However, the noise levels at 27 and at 6 kHz increased and reached their maxima after about 15 seconds. Furthermore, substantial noise at 1.5 kHz was first apparent at 5 seconds after lift-off and also peaked out in about 15 seconds.

If the Saturn V vehicle is charged to a potential of several million volts, corona discharges will be produced which, in turn, generate radio noise. The onset of these discharges should occur very soon after lift-off and reach a maximum when the launch vehicle is still close to the ground. Radio noise records strongly support this conclusion. The sudden onset of the noise probably corresponds closely to lift-off. It is interesting that, at about 15 seconds after lift-off, the noise became enhanced at the lower rather than the higher frequencies. This phenomenon implies that larger discharges occur at these times. The most intense discharges would be expected to occur soon after the launch vehicle and its exhaust plume clear the launch tower.

11.1.3 Measurement of Telluric Current

The experiment to measure telluric current consisted of an electrode placed close to the launch site and two electrodes spaced approximately 2500 feet from the base electrode at a 90-degree included angle (shown in figure 11.1-2). The telluric current system failed to detect any launch effects. It was expected that the current would show an increase until the vehicle exhaust plume broke effective electrical contact with ground. The high density of metallic conductors in the ground near the launch site may have functioned as a short circuit, which would have negated the detection of any changes in the current level.

11.1.4 Measurement of the Air/Earth Current Density

Three balloons containing instruments designed to measure the air/earth current density were launched: at 6:52 p.m. on April 9, 1970, and at 1:14 p.m. and 1:52 p.m. on April 11, 1970. The first two balloons provided the "fair weather" base for the experiment. At lift-off, the third balloon was about 12.2 miles southeast of the launch site at an

altitude of 20 000 feet. Forty-five seconds after lift-off, the current density, which had been oscillating at a frequency of about 15 cycles per minute, showed a marked increase in amplitude. This variation in current was again observed when the balloon reached an altitude between 40 000 and 50 000 feet. The frequency of the observed current variation was also noted from the balloon released at 1:14 p.m. The cause of the oscillating current and the enhancement thereof are not yet understood.

11.2 EARTH PHOTOGRAPHY APPLIED TO GEOSYNCHRONOUS SATELLITES

The determination of the wind field in the atmosphere is one of the prime requirements for accurate long-range numerical weather prediction. Wind fields are also the most difficult to measure with the desired sample density (as discussed in ref. 4). The output of the geosynchronous Advanced Technology Satellites I and III is now being used as a crude estimate of wind fields by comparing the translation of clouds between successive frames 20 minutes apart. This comparison does not define the wind field, however, as a function of height above the surface, which is an important restriction to data application. The ability to determine the height of cloud elements would add this dimension to the satellite wind field analysis. A capability to determine cloud height has been demonstrated by use of stereographic photogrammetry on low altitude photographs taken from Apollo 6 (ref. 5). This success suggests that cloud heights and therefore wind velocity may also be determined by using data gathered from pairs of geosynchronous satellites located 10 to 20 degrees apart in longitude. Calculations indicate, however, that stereoscopic determination of cloud heights from geosynchronous altitudes would be marginal, at best, because of the small disparity angles involved (ref. 6).

To aid in a test of the feasibility of performing stereoscopic determination of cloud height at synchronous altitudes, a series of earth-centered photographs at 20-minute intervals, beginning soon after translunar injection, were planned. The photographs required for this test could only have been acquired from an Apollo lunar mission. A precise record of time of photography was required to reconstruct the geometry involved. Eleven photographs were taken, and a precise time record was obtained. The description of the location of the spacecraft at the time of each photograph is given in table 11.2-1, along with the time of photography, the enlargement required on each frame for normalization, and the distance between photographic points. The experiment was successful, and all photographs are of excellent quality. To support the analysis of these photographs, aircraft reports, synoptic weather charts and satellite photographs for the time of photography have been acquired. Unfortunately, Advanced Technology Satellite I was out of operation on the day of photography.

TABLE 11.2-I.- EARTH WEATHER PHOTOGRAPHY

Magazine & frame	Mission elapsed time hr:min:sec	Gst hr:min:sec	Latitude	Longitude	Altitude		Normalization enlargement required	Distance apart mils
					Mile	Earth radii (from center)		
13-60-8590	07:17:14	02:30:46	28°38'N ^a	135°00'W ^a	34 900	6.076	1.00000	
13-60-8591	07:39:47	02:52:49	28°25'N	134°33'W	37 054	6.389	1.0617	1473.5
13-60-8592	08:42:07	03:55:09	27°49'N ^a	147°32'W ^a	42 160	7.280	1.2372	4409.2
13-60-8593	09:03:11	04:16:13	27°39'N	151°39'W	44 996	7.545	1.2893	1609.5
13-60-8594	09:26:34	04:29:36	27°24'N	156°35'W	47 096	7.850	1.3495	1962.8
13-60-8595	09:47:10	05:00:12	27°14'N ^a	161°00'W ^a	48 970	8.116	1.4017	1649.0
13-60-8596	10:00:35	05:21:41	27°04'N	165°49'W	49 876	8.255	1.4292	2240.4
13-60-8597	10:30:59	05:44:01	26°54'N	170°30'W	51 655	8.513	1.4800	2202.6
13-60-8598	10:52:55	06:06:01	26°45'N ^a	175°02'W ^a	53 401	8.767	1.5301	2275.5
13-60-8599	11:14:35	06:20:01	26°36'N	179°14'W	55 056	9.006	1.5770	2296.8
13-60-8600	11:37:19	06:50:21	26°27'N	174°29'W	56 728	9.251	1.6254	2436.6

^aPositions are extrapolated.

The 11 photographs have been normalized so that the earth is the same size in all frames. Frames 8590 and 8591 have been further enlarged. By viewing these two frames under a stereoscope, pronounced apparent relief is seen in the cloud patterns. The relief is so pronounced, in fact, that it cannot be attributed solely to height differences of clouds. It appears to result, in part, from the relative horizontal motion in the cloud fields; that is, clouds moving in the same direction as the spacecraft appear farther away than those moving in the direction opposite that of the spacecraft.

11.3 SEISMIC DETECTION OF THIRD STAGE LUNAR IMPACT

In prior lunar missions, the third stage has been separated from the spacecraft with the intention of entering a solar orbit through a near-miss, or "slingshot," approach to the moon. For Apollo 13, an opportunity was available to gain further data on large-mass impact phenomena which could be derived using the seismic equipment deployed during Apollo 12. The impact of the lunar module ascent stage during Apollo 12 pointed up certain unexplained seismological events which the S-IVB impact was expected to reproduce.

The S-IVB impacted the lunar surface at 8:09:41 p.m. e.s.t., April 14, 1970, travelling at a speed of 5600 miles/hr. Stage weight at the time of impact was 30 700 pounds. The collision occurred at a latitude of 2.4 degrees south and a longitude of 27.9 degrees west, which is approximately 74 miles west-northwest from the experiment station installed during Apollo 12. The energy release from the impact was equivalent to an explosion of 7.7 tons of trinitrotoluene (TNT).

Seismic signals were first recorded 28.4 seconds after impact and continued for over 4 hours. Some signals were so large that seismometer sensitivity had to be reduced by command from earth to keep the data on scale. Peak signal intensity occurred 10 minutes after initial onset. The peak value was 8 times larger than that recorded from the Apollo 12 ascent stage impact, which occurred at a range of 40 miles from the seismic station and was equivalent to 1 ton of TNT. An expanding gas cloud, which presumably swept out over the lunar surface from the S-IVB impact point, was recorded by the lunar ionosphere detector deployed during Apollo 12. Detection of this cloud began approximately 8 seconds before the first seismic signal and lasted 70 seconds.

The character of the signal from the S-IVB impact is identical to that of the ascent stage impact and those from natural events, presumed to be meteoroid impacts, which are being recorded at the rate of about one per day. The S-IVB seismic energy is believed to have penetrated into the moon to a depth of from 20 to 40 kilometers. The initial signal was unusually clear and travelled to the seismic station at a velocity of 4.8 km/sec, which is near that predicted from laboratory measurements using Apollo 12 lunar rock samples. This result implies that, to depths of at least 20 kilometers, the moon's outer shell may be formed from the same crystalline rock material as found at the surface. No evidence of a lower boundary to this material has been found in the seismic signal, although it is clear the material is too dense to form the entire moon.

An unexplained characteristic of the S-IVB impact is the rapid buildup from its beginning to the peak value. This initial stage of the signal cannot be explained solely by the scattering of seismic waves in a rubble-type material, as was thought possible from the ascent stage impact data. Several alternate hypotheses are under study, but no firm conclusions have been reached. Signal scattering, however, may explain the character of the later part of the signal.

The fact that such precise targeting accuracy was possible for the S-IVB impact, with the resulting seismic signals so large, have greatly encouraged seismologists to study possible future S-IVB impacts. For ranges extended to 500 kilometers, the data return could provide a means for determining moon structures to depths approaching 200 kilometers.

12.0 ASSESSMENT OF MISSION OBJECTIVES

The four primary objectives (see ref. 7) assigned to the Apollo 13 mission were as follows:

- a. Perform selenological inspection, survey, and sampling of materials in a preselected region of the Fra Mauro formation.
- b. Deploy and activate an Apollo lunar surface experiments package.
- c. Further develop man's capability to work in the lunar environment.
- d. Obtain photographs of candidate exploration sites.

Thirteen detailed objectives, listed in table 12-I and described in reference 8, were derived from the four primary objectives. None of these objectives were accomplished because the mission was aborted. In

TABLE 12-I.- DETAILED OBJECTIVES AND EXPERIMENTS

Description		Completed
B	Television coverage	No
C	Contingency sample collection	No
D	Selected sample collection	No
E	Evaluation of landing accuracy techniques	No
F	Photographs of candidate exploration sites	No
G	Extravehicular communication performance	No
H	Lunar soil mechanics	No
I	Dim light photography	No
J	Selenodetic reference point update	No
K	CSM orbital science photography	No
L	Transearth lunar photography	No
M	EMU water consumption measurement	No
N	Thermal coating degradation	No
ALSEP III	Apollo lunar surface experiments package	No
S-059	Lunar field geology	No
S-080	Solar wind composition	No
S-164	S-band transponder exercise	No
S-170	Downlink bistatic radar observations of the Moon	No
S-178	Gegenschein from lunar orbit	No
S-184	Lunar surface close-up photography	No
T-029	Pilot describing function	Yes

addition to the spacecraft and lunar surface objectives, the following two launch vehicle secondary objectives were assigned:

a. Attempt to impact the expended S-IVB stage on the lunar surface within 350 km of the targeted impact point of 3 degrees south latitude and 30 degrees west longitude under nominal flight control conditions to excite the Apollo 12 seismometer.

b. Postflight determination of the actual time and location of S-IVB impact to within 1 second.

Both objectives were accomplished, and the results are documented in reference 2. The impact was successfully detected by the seismometer and is reported in greater detail in section 11.3.

Seven scientific experiments, in addition to those contained in the lunar surface experiment package, were also assigned as follows:

- a. Lunar field geology (S-059)
- b. Pilot describing function (T-029)
- c. Solar wind composition (S-080)
- d. S-band transponder exercise (S-164)
- e. Downlink bistatic radar observations of the moon (S-170)
- f. Gegendeschein observation from lunar orbit (S-178)
- g. Lunar surface closeup photography (S-184)

The pilot describing function experiment (T-029) was a success, in that data were obtained during manually controlled spacecraft maneuvers which are available to the principle investigator. None of the other experiments was attempted.

13.0 LAUNCH VEHICLE SUMMARY

The Apollo 13 space vehicle was launched from pad A of complex 39, Kennedy Space Center, Florida. Except for the high-amplitude, low-frequency oscillations which resulted in premature cutoff of the S-II center engine, the basic performance of the launch vehicle was normal. Despite the anomaly, all launch vehicle objectives were achieved, as discussed in reference 2. In addition, the S-IVB lunar impact experiment was accomplished, as discussed in section 11.3.

The vehicle was launched on an azimuth 90 degrees east of north, and a roll maneuver at 12.6 seconds placed the vehicle on a flight azimuth of 72.043 degrees east of north. Trajectory parameters were close to nominal during S-IC and S-II boost until early shutdown of the center engine. The premature cutoff caused considerable deviations from certain nominal launch-vehicle trajectory parameters which were particularly evident at S-II outboard engine cutoff. Despite these deviations, the guidance system is designed to operate such that an efficient boost is conducted under engine-out conditions, and near-nominal trajectory parameters were achieved at orbital insertion and at translunar injection. Because of the reduced effective thrust, however, these respective events occurred 44.07 and 13.56 seconds later than predicted. After spacecraft ejection, various S-IVB attitude and propulsive maneuvers placed the vehicle on a lunar impact trajectory very close to the desired target (section 11.3).

Structural loads experienced during S-IC boost were well below design values, with maximum lateral loads approximately 25 percent of the design value. As a result of high amplitude longitudinal oscillations during S-II boost, the center engine experienced a 132-second premature cutoff. At 330.6 seconds, the S-II crossbeam oscillations reached a peak amplitude of $\pm 33.7g$. Corresponding center-engine chamber pressure oscillations of ± 225 psi initiated engine cutoff through the "thrust OK" switches. These responses were the highest measured amplitude for any S-II flight. Except for the unexpected high amplitude, oscillations in this range are an inherent characteristic of the present S-II structure/propulsion configuration and have been experienced on previous flights. Acceleration levels experienced at various vehicle stations during the period of peak oscillations indicate that the vehicle did not transmit the large magnitude oscillations to the spacecraft. Installation of an accumulator in the center-engine liquid oxygen line is being incorporated on future vehicles to decouple the line from the crossbeam, and therefore suppress any vibration amplitudes. Addition of a vibration detection system which would monitor structural response in the 14-to-20 Hz range and initiate engine cutoff if vibrations approach a dangerous level is also under investigation as a backup.

13-2

The pilot describing function experiment (T-029) was a success, in that data were obtained during manually controlled spacecraft maneuvers which are available to the principle investigator. None of the other experiments was attempted.

14.0 ANOMALY SUMMARY

This section contains a discussion of the significant problems or discrepancies noted during the Apollo 13 mission.

14.1 COMMAND AND SERVICE MODULES

14.1.1 Loss of Cryogenic Oxygen Tank 2 Pressure

At approximately 55 hours 55 minutes into the Apollo 13 mission, the crew heard and felt the vibrations from a sharp "bang," coincident with a computer restart and a master alarm associated with a main-bus-3 undervoltage condition. Within 20 seconds, the crew made an immediate verification of electrical-system parameters, which appeared normal. However, the crew reported the following barberpole indications from the service module reaction control system:

- a. Helium 1 on quads B and D
- b. Helium 2 on quad D
- c. Secondary propellant valves on quads A and C.

Approximately 2-1/2 minutes after the noise, fuel cells 1 and 3 ceased generating electrical power.

The first indication of a problem in cryogenic oxygen tank 2 occurred when the quantity gage went to a full-scale reading at 46 hours 40 minutes. For the next 9 hours, system operation was normal. The next abnormal indication occurred when the fans in cryogenic oxygen tank 2 were turned on at 55:53:20. Approximately 2 seconds after energizing the fan circuit, a short was indicated by the current trace from fuel cell 3, which was supplying power to the oxygen tank 2 fans. Within several additional seconds, two other shorted conditions occurred.

Electrical shorts in the fan circuit ignited the wire insulation, causing pressure and temperature increases within oxygen tank 2. During the pressure rise period, the fuses opened in both fan circuits in cryogenic oxygen tank 2. A short-circuit conduction in the quantity gaging system cleared itself and then began an open-circuit condition. When the pressure reached the tank-2 relief-valve full-flow conditions of 1008 psia, the pressure decreased for about 9 seconds, after which time the relief valve probably reseated, causing another momentary pressure increase. Approximately 1/4 second after this momentary pressure increase, a vibration disturbance was noted on the command module accelerometers.

The next series of events occurred within a fraction of a second between the accelerometer disturbances and a momentary loss of data. Burning of the wire insulation reached the electrical conduit leading from inside the tube to the external plug causing the tank line to burst because of overheating. The ruptured electrical conduit caused the vacuum jacket to over pressurize and, in turn, caused the blow-out plug in the vacuum jacket to rupture. Some mechanism, possibly the burning of insulation in bay 4 combined with the oxygen buildup in that bay, caused a rapid pressure rise which resulted in separation of the outer panel. Ground tests, however, have not substantiated the burning of the Mylar insulation under the conditions which probably existed just after the tank rupture. The panel separation shock closed the fuel cell 1 and 3 oxygen reactant shut-off valves and several propellant and helium isolation valves in the reaction control system. Data were lost for about 1.8 seconds as the high-gain antenna switched from narrow beam to wide beam, because the panel, when separating, struck and damaged one of the antenna dishes.

Following recovery of the data, the vehicle had experienced a translation change of about 0.4 ft/sec, primarily in a plane normal to bay 4. The oxygen tank 2 pressure indication was at the lower limit of the read-out. The oxygen tank 1 heaters were on, and the tank 1 pressure was decaying rapidly. A main-bus-3 undervoltage alarm and a computer restart also occurred at this time.

Fuel cells 1 and 3 operated for about 2-1/2 minutes after the reactant valves closed. During this period, these fuel cells consumed the oxygen trapped in the plumbing, thereby reducing the pressure below minimum requirements and causing total loss of fuel cell current and voltage output from these two fuel cells. Because of the loss of performance by two of the three fuel cells and the subsequent load switching by the crew, numerous associated master alarms occurred as expected.

Temperature changes were noted in bays 3 and 4 of the service module in response to a high heat pulse or high pressure surge. Fuel cell 2 was turned off about 2 hours later because of the loss of pressure from cryogenic oxygen tank 1.

The cryogenic oxygen tank design will be changed to eliminate the mechanisms which could initiate burning within the tank and ultimately lead to a structural failure of the tank or its components. All electrical wires will be stainless-steel sheathed and the quantity probe will be made from stainless steel instead of aluminum. The fill-line plumbing internal to the tank will be improved, and a means of warning the crew of an inadvertent closure of either the fuel cell hydrogen or oxygen valves will be provided. A third cryogenic oxygen tank will be added to the service module for subsequent Apollo missions. The fuel cell oxygen

supply valve will be redesigned to isolate polytetrafluoroethylene-coated wires from the oxygen. Warning systems at the Mission Control Center will be modified to provide more immediate and visible warnings of anomalies in all systems.

A more thorough discussion of this anomaly is presented in reference 1.

This anomaly is closed.

14.1.2 Postlanding Vent Valve Malfunction

During postlanding activities, recovery personnel discovered that the postlanding ventilation inlet valve was closed and the exhaust valve was open.

The ventilation valve is opened by first pulling the postlanding vent valve unlock handle. The handle is attached by a cable to two pins which mechanically lock the ventilation valves closed. Once the handle is pulled, the postlanding vent fan switch is placed to either the high or low position. This operation opens both ventilation valves and actuates the postlanding blower. The recovery forces found the switch setting to be proper, but the vent valve unlock handle was partially out instead of completely out.

The inlet valve locking pin was not in the full open position (fig. 14-1), a condition which would keep the valve in the closed position even though both the pin and slot were measured to be within design tolerances.

A check of the operation of the valves with different pull positions of the handle from locked to full open requires about one inch of travel and was made with the following results:

- a. With the handle extended only $1/4$ inch or less from the valve locked position, both plungers remained locked.
- b. With the handle extended from $5/16$ to $3/8$ inch from the valve-locked position, the exhaust valve opened but the inlet valve remained closed. This condition duplicates that of the position of the handle and the operation of the valve found on the Apollo 13 spacecraft after flight.
- c. When the handle was extended from $3/8$ inch to full travel from the valve-locked position, both the inlet and exhaust valves opened.

Testing verified that application of power to the valves while the locking pins are being released will prevent the pin from being pulled to the unlock position because the drive shaft torque binds the lock pin.

NASA-5-70-5841

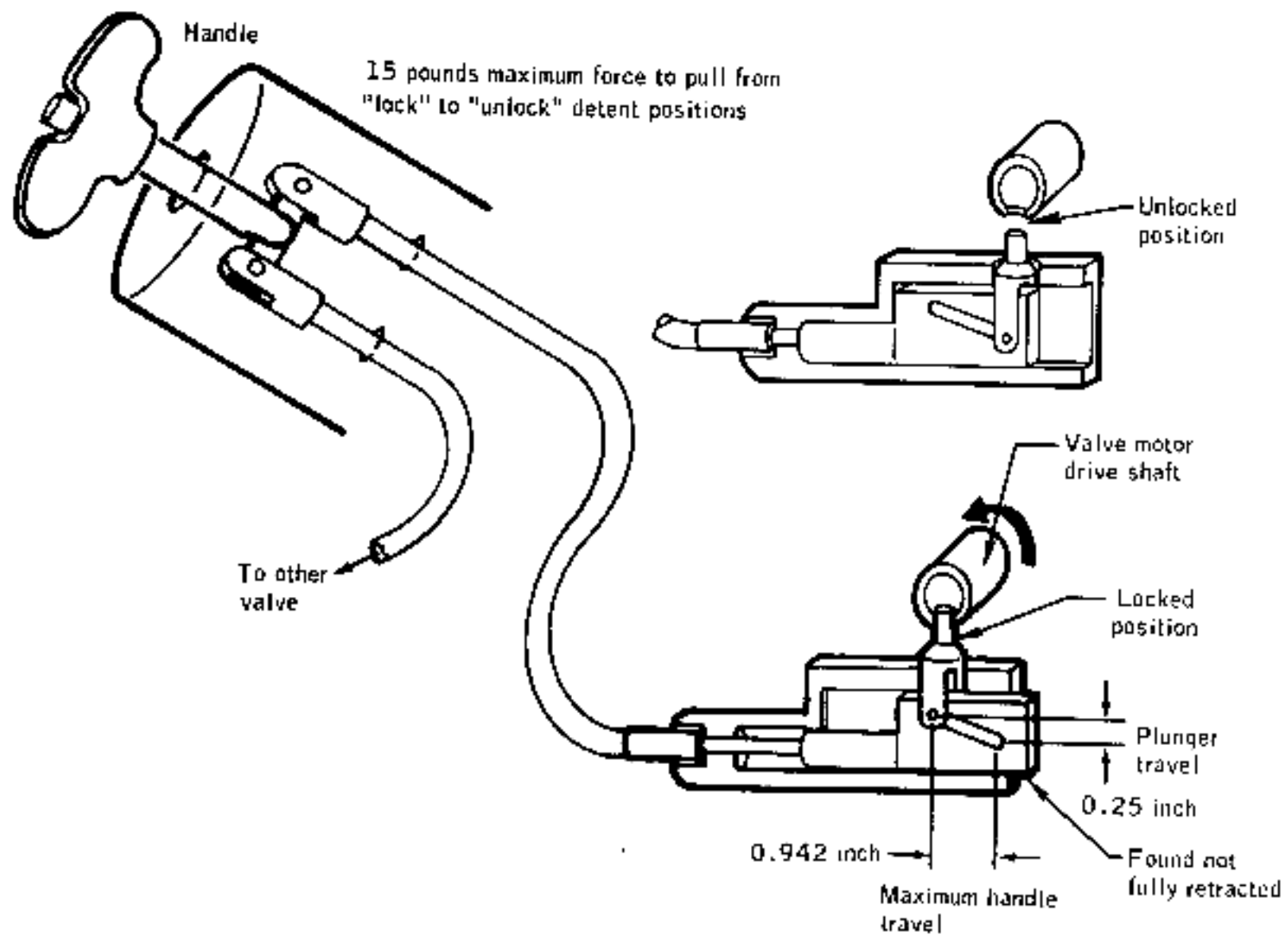

Figure 14-1.- Post-landing vent valve lock.

The valve-lock mechanism rigging tolerances were found to be within specifications. When reassembled in the spacecraft, the malfunction was duplicated with only partial travel of the handle.

The ventilation system was designed with two flexible control-cable assemblies linked to one handle, which is pulled to operate the two valves. An inherent characteristic of this design is that one control cable will nearly always slightly lag the other when the handle is pulled. At full extension of the handle, the travel in each cable assembly is more than sufficient to disengage both plungers and allow both valves to operate. Checkout procedures prior to flight were found to be satisfactory. There was no evidence of mechanical failure or malfunction nor were any out-of-tolerance components found.

To guard against operational problems of this type in the future, a caution note has been added in the Apollo Operations Handbook to actuate the ventilation valve handle over its full travel before switching on the postlanding vent fan.

This anomaly is closed.

14.1.3 Shaft Fluctuations in the Zero Optics Mode

Beginning at approximately 40 hours, fluctuations of as much as 0.3 degree were observed in the computer readout of the optics shaft angle. The system had been powered up throughout the flight and had been in the zero optics mode since the star/horizon navigation sightings at 31 hours. Crew observation of the manual readout subsequently confirmed that the fluctuation was actually caused by motion of the shaft. The circumstances and time of occurrence were almost identical to a similar situation which occurred during the Apollo 12 mission.

A simplified schematic of the optics shaft servo loop mechanization is shown in figure 14-2. In the zero optics mode, the sine outputs of

NASA-S-70-5842

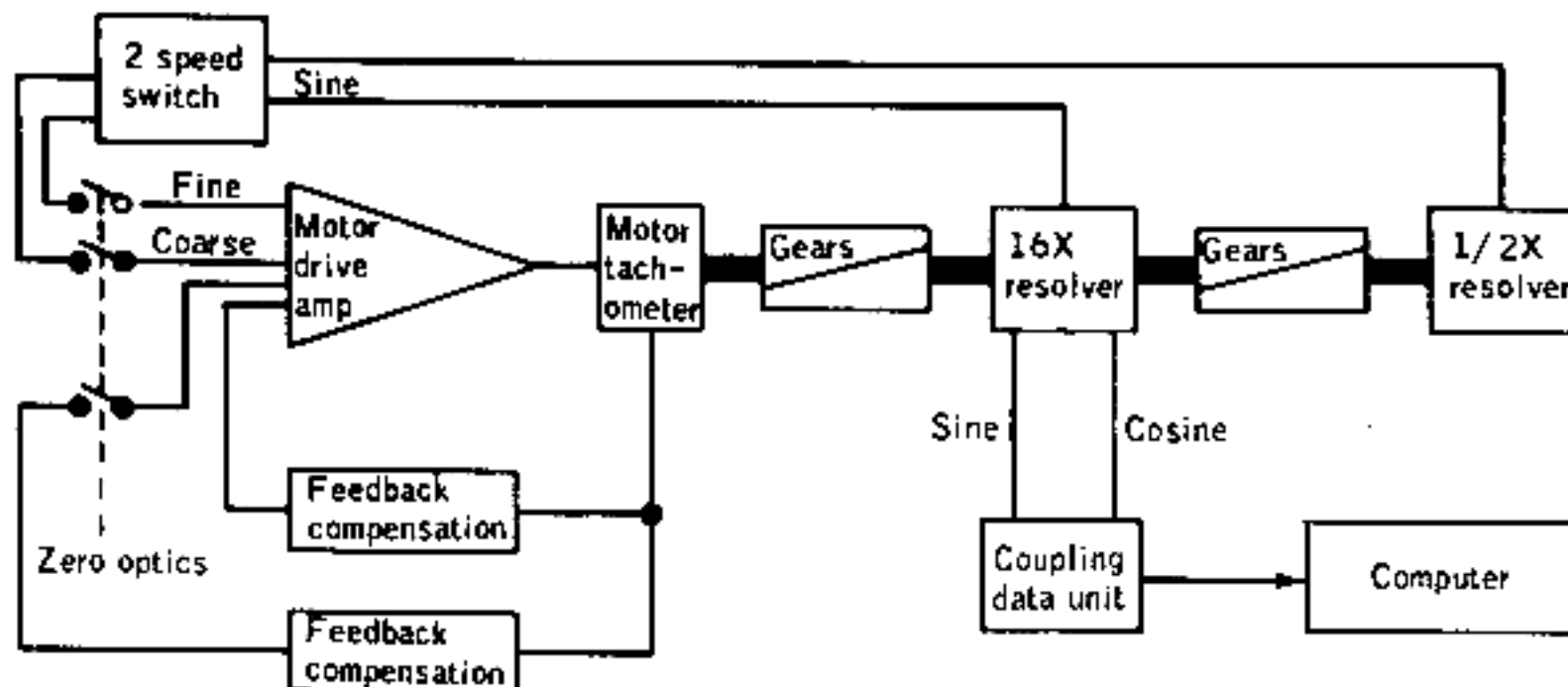

Figure 14-2.- Zero optics mode circuitry.

the half-speed and 16-speed resolvers are routed through a coarse/fine switching network to the motor drive amplifier and are used to null the system. Rate feedback from the motor tachometer is routed to the drive amplifier through a compensation network which removes any bias in the signal. When the zero optics mode is selected, the coupling-data-unit counter and the computer register which contains the shaft angle are zeroed for 15 seconds and then released to follow the 16-speed resolver. The half-speed resolver, the fine/coarse switching network, and the tachometer feedback compensation are used only in the zero optics mode.

An investigation conducted after Apollo 12 did not identify a definite source of the problem, since extreme corrosion from sea water after landing prevented meaningful examination of the mechanical drive system and restricted testing to the power and servo assembly which contains the major electronic components. No abnormal indications were found in the Apollo 12 system; however, the failure symptoms were reproduced on a breadboard by breaking down the isolation across a transformer in the tachometer feedback compensation network. Although depotting and testing of the actual transformer failed to produce any evidence of malfunction, this mechanism was considered a likely candidate for a random failure.

The recurrence of the problem under almost identical circumstances during Apollo 13 indicates that the cause is more likely generic than random and that it is time or vacuum dependent. The susceptibility of the shaft axis rather than the trunnion axis also tends to absolve components common to both axes, such as the electronics and the motor drive amplifier. The shaft loop has been shown to be more sensitive than the trunnion to harmonics of the 800-hertz reference voltages introduced into the forward loop; however, because the level of the required null offset voltage is well above that available by induction, this mechanism is considered unlikely.

The most likely candidate is the half-speed resolver, which is used only for the shaft axis and only to provide an unambiguous zero reference. The reference voltage is applied to the rotor through slip rings (fig. 14-3), connected as shown in figure 14-4. If any resistance is present in the common ground path through the slip ring, a portion of the reference voltage will appear across the quadrature winding and induce a finite output (different than zero). Zero output is equivalent to zero degrees in shaft rotation.

Simulated changes in slip ring impedance were made on the half-speed resolver in the shaft loop (fig. 14-4). An impedance of 50 ohms produced an offset of approximately plus 0.5 degree in sextant shaft angle. The trunnion loop does not use this type of resolver or connection.

Some evidence of susceptibility to vacuum was exhibited in this class of resolvers during qualification testing when variations of approximately 5 ohms were observed in the slip ring resistance during thermal

NASA-S-70-5843

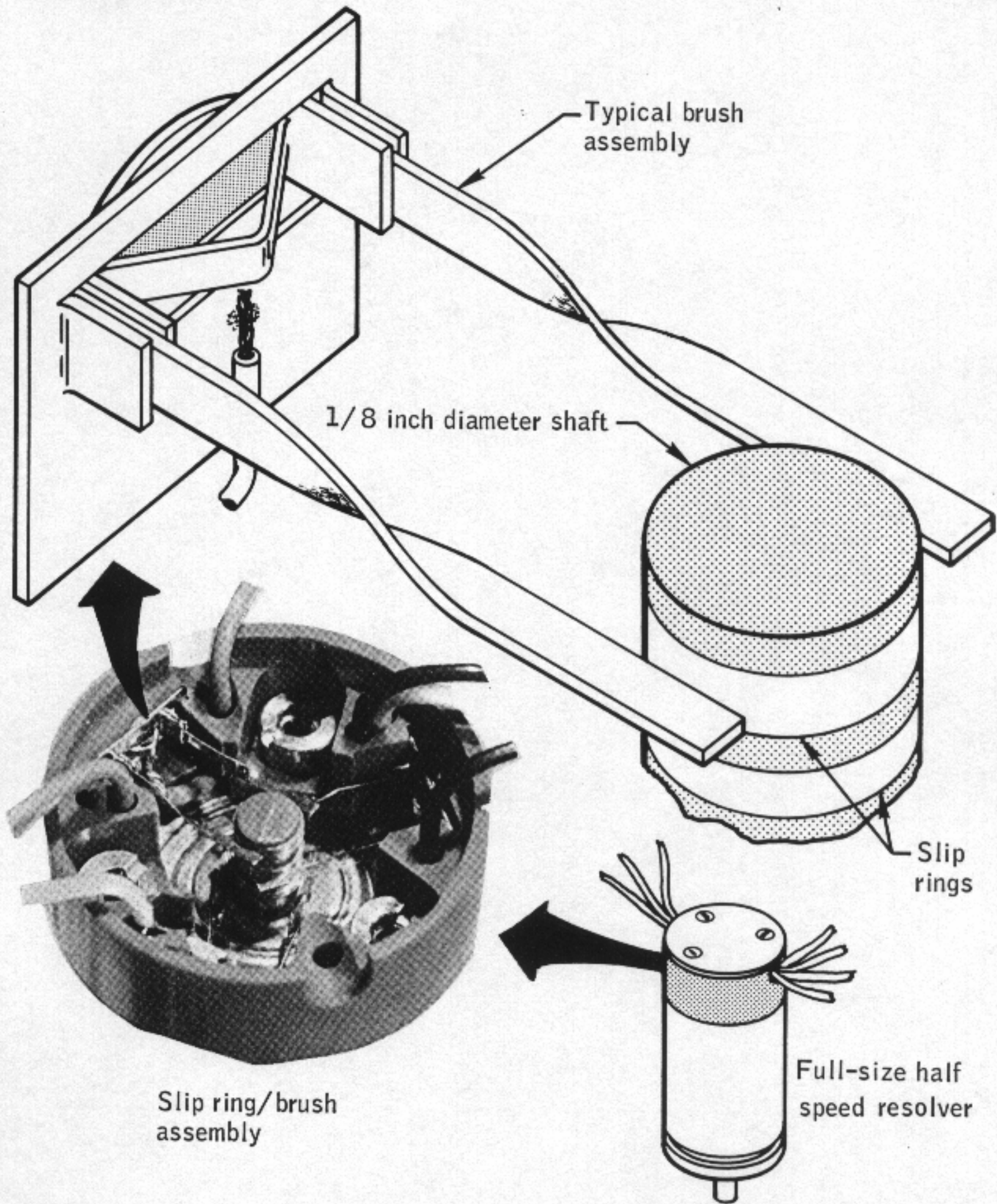

Figure 14-3.- Details of half speed resolver.

NASA-S-70-5844

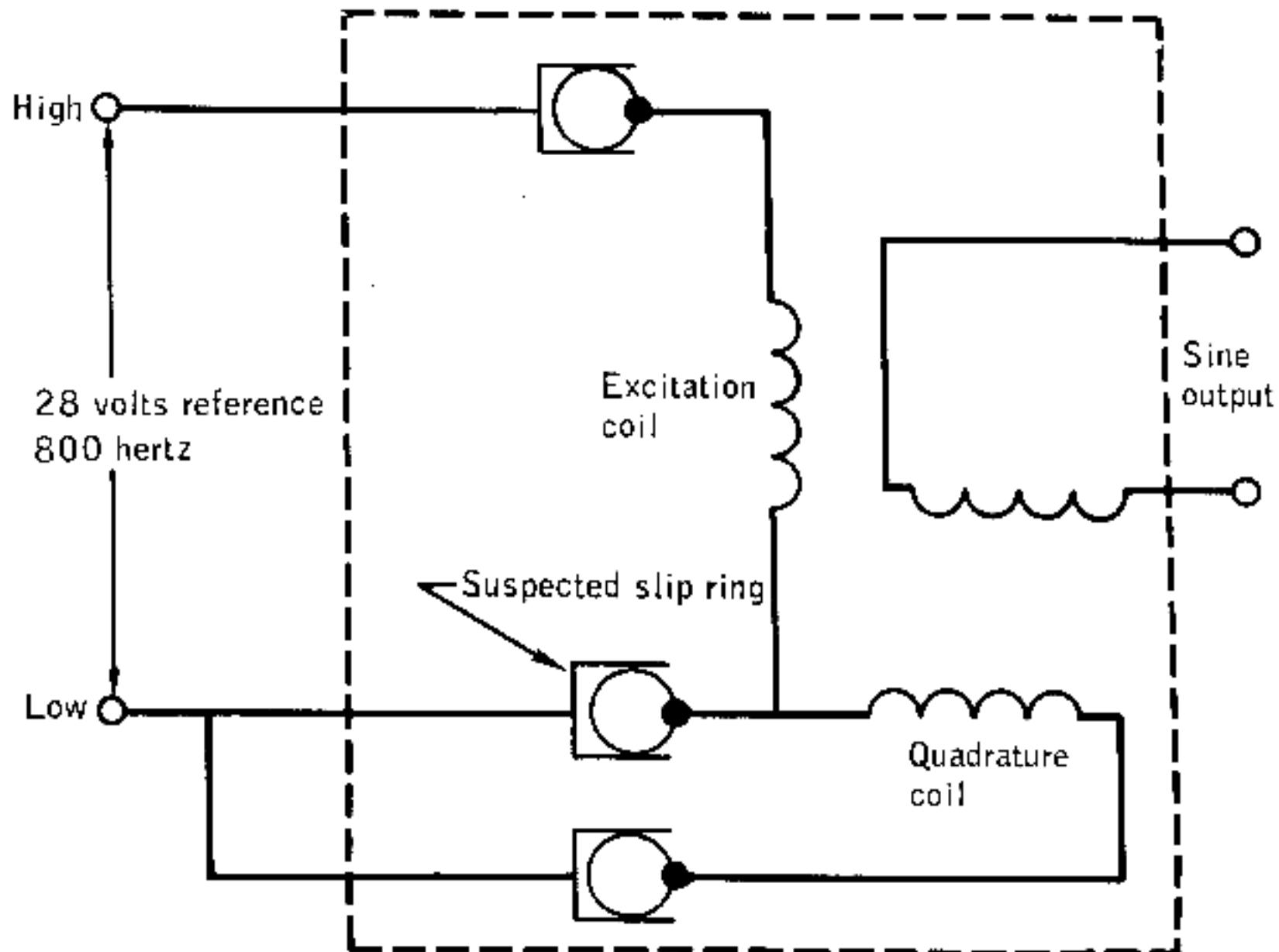

Figure 14-4.- One-half speed resolver.

vacuum testing. The tests were run with the units rotating at 1 rpm, however, and the momentary resistance changes disappeared with the wiping action.

The testing of the half-speed resolver with resistance in the low side of the sine winding and the vacuum susceptibility exhibited during qualification testing closely duplicate the characteristics of inflight "zero optics" operation. The slip-ring mechanism is unique to the shaft-axis, since none of the other resolvers in the system use slip rings. This resolver is in the optics head, which is vented to a vacuum. The rotation of the optics head in a normal operation would wipe the slip rings clean and explain the delay in the fluctuations for some hours after selecting zero optics.

Corrective action to high resistance on the brush/slip rings of the resolver is not required since accurate zeroing is unaffected and there is no effect in the operation of the system other than system readout when not in use. This condition can be expected to recur in future Apollo flight. Future crews will be briefed on this situation.

This anomaly is closed.

14.1.4 High-Gain Antenna Acquisition Problem

Prior to the television transmission at approximately 55 hours, difficulty was experienced in obtaining high-gain antenna acquisition and tracking. The Command Module Pilot had manually adjusted the antenna settings to plus 23 degrees in pitch and 267 degrees in yaw, as requested by the ground 7 hours earlier. The most favorable settings for 55 hours were actually plus 5 degrees in pitch and 237 degrees in yaw. The difference between these two sets of angles pointed the antenna boresight axis approximately 35 degrees away from the line of sight to the ground station.

When the transmission was switched from the omnidirectional antenna to the manual mode of the high-gain antenna, there was a 6 dB decrease in uplink signal strength and a 17 dB decrease in downlink signal strength. With the high-gain antenna in the wide beam mode and nearly boresighted, the uplink and downlink signal strengths should have been at least equal to the signal strength obtained with an omnidirectional antenna. A comparison of the wide-, medium-, and narrow-beam transmit and receive patterns indicates the high-gain antenna mode was in a medium-beam, manual mode at the time of acquisition and remained in this configuration until the reacquisition mode was selected at 55:00:10.

Starting at 55:00:10 and continuing to 55:00:40, deep repetitive transients approximately every 5 seconds were noted on the phase modulated downlink carrier (fig. 14-5). This type of signature can be caused by a malfunction which would shift the scan-limit and scan-limit-warning function lines, as illustrated in figure 14-5. These function lines would have to shift such that they are both positioned between the antenna manual settings and the true line of sight to earth. Also, the antenna would have to be operating in the auto-reacquisition mode to provide these signatures. The antenna functions which caused the cyclic inflight RF signatures resulting from a shift in the function lines can be explained with the aid of figures 14-5 and 14-6, with the letters A, B, C, and D corresponding to events during the cycle. Starting at approximately 55:00:10, the antenna was switched from manual to auto reacquisition with the beamwidth switch in the medium-beam position. From point A to the scan limit function line just prior to point B, the antenna acquired the earth in wide beam. When the antenna reached the scan limit function line, the antenna control logic would switch the system to the manual

NASA-S-70-5845

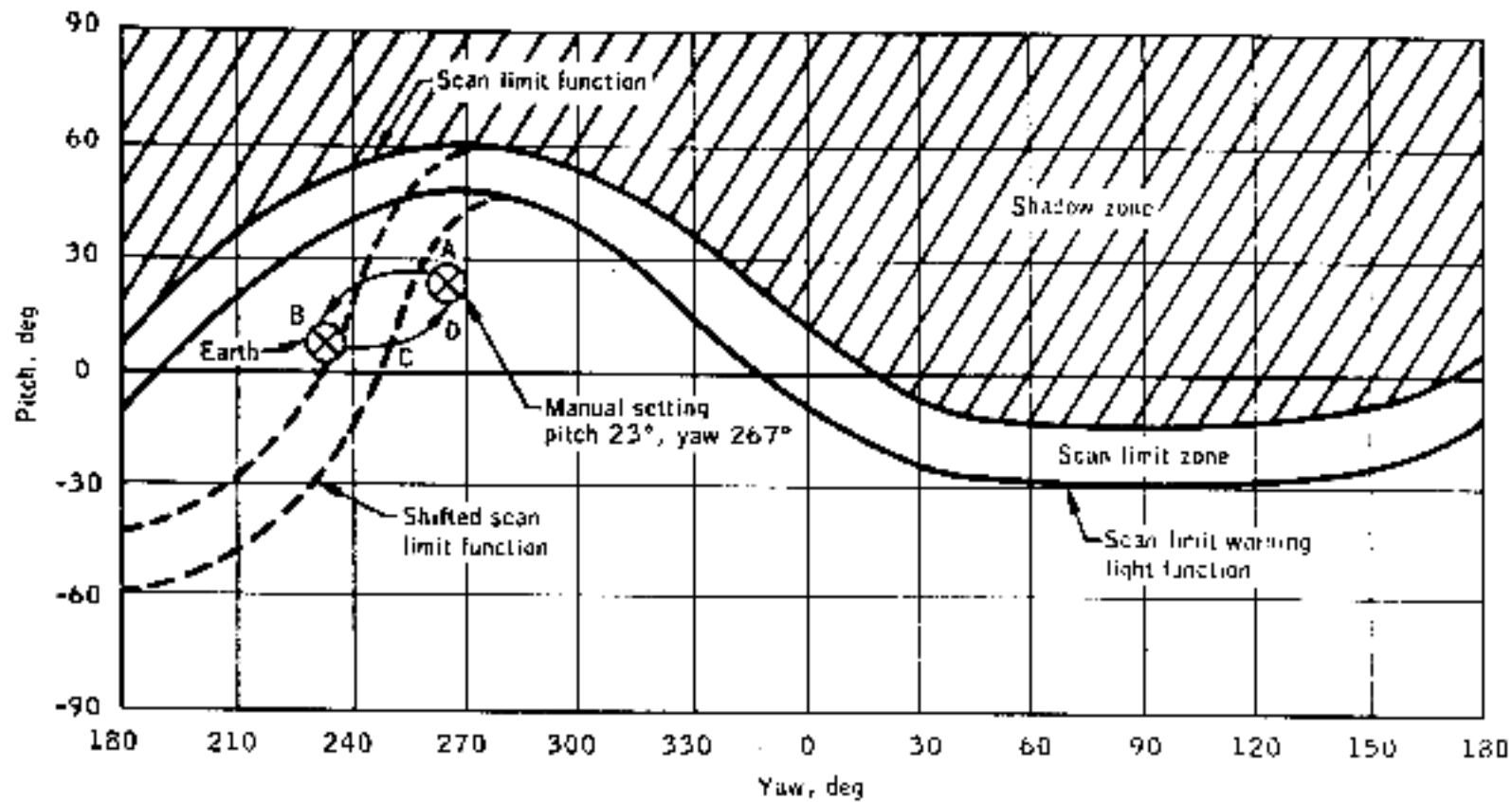

Figure 14-5.- Shift in scan-limit, scan-limit-warning illustrated.

mode and drive back toward the manual settings until the scan limit warning function line at point C was reached, thereby maintaining wide-beam operation. When the antenna reaches the scan limit warning function line, the system would automatically switch to the medium-beam mode and continue to drive in the manual mode until the manual setting error was nulled out at point A. The antenna would then switch to the auto-track mode and repeat the cycle. The most important feature of this cycle is that the antenna moves at the manual scan rate between points B and D, which is confirmed by the rapid changes in the downlink signal strength.

System testing with a similar antenna and electronics box showed RF signatures comparable to those observed in flight. This consistency was accomplished by placing the target inside the scan limits and the manual setting outside the scan limits. These two positions were separated approximately 35 degrees, which matched the actual angular separation experienced. Under these conditions, the antenna cycled between the target and the manual setting while operating in the auto-reacquisition mode and produced the cyclic RF signature. Since the inflight loss of signal to earth was not near the scan limit, the failure mechanism would be a shift in the scan-limit function line.

Elements in the scan-limit and scan-limit-warning circuit were shorted and opened to determine the effect on the scan-limit shift. The

NASA-5-70-5846

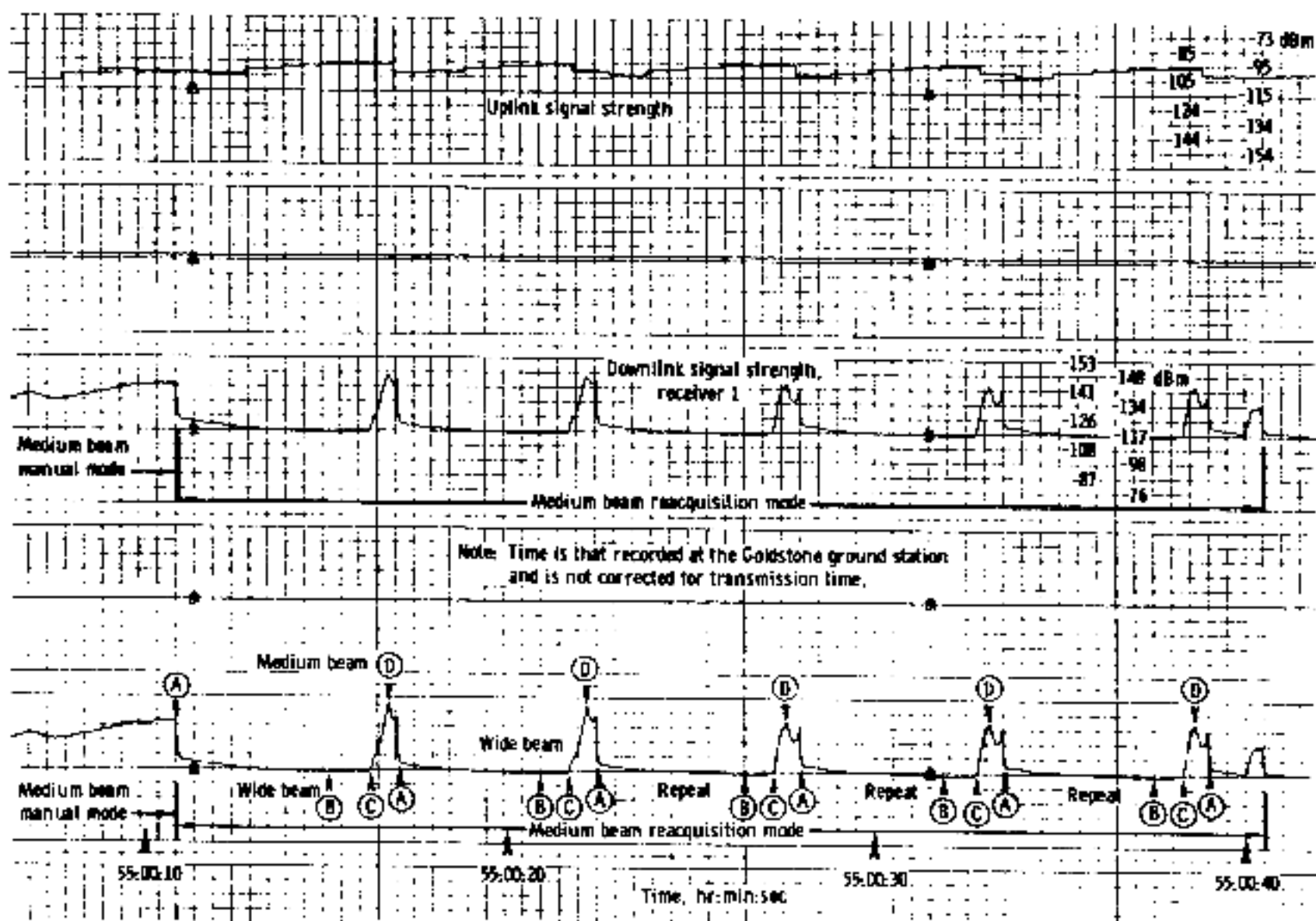

Figure 14-6.- Recorded signal strengths during high-gain antenna operation.

results of this test shifted the scan-limit functions but did not produce the necessary change in the scan-limit slope. Consequently, a failure in the electronic box is ruled out.

The only component identified with a failure mode that would produce a shift in the scan-limit functions and a shift change is the C-axis induction potentiometer located in the antenna. This potentiometer is used to provide a voltage proportional to the C-axis angular orientation and consists of three separate coils, each with symmetrical winding on opposite sides of the rotor or stator. These coils include the primary winding on the stator, the compensation or bias winding on the stator, and the linear output winding located on the rotor. The bias winding is used to shift the normal ± 70 degrees linear output to a new linear output over the range of from minus 10 to plus 130 degrees.

The voltages for the C-axis induction potentiometer and the A-axis function generator, also located in the antenna, add together in the

electronic box and trigger the antenna logic to produce the scan-limit functions when the voltage sum reaches a threshold value. Under normal operating conditions, the threshold voltage is reached when the C-axis angular travel is between 95 and 115 degrees.

The failure mode of the C-axis induction potentiometer is a short in the stator excitation winding. Shorting one half of the stator's primary winding to ground would produce a greater slope in the curve showing the induction potentiometer transformation ratio versus angular travel. This slope increase would produce nonlinear effects because the magnetic flux is concentrated in one-half of the primary winding. Further analysis is in progress to establish the particular failure and what might have caused the condition.

A test will be performed at the launch site on future spacecraft to preclude launching with either a bad C-axis or A-axis generator.

An anomaly report will be published when the analysis is complete.

This anomaly is open.

14.1.5 Entry Monitor System 0.05g Light Malfunction

The entry monitor system 0.05g light did not illuminate within 3 seconds after an 0.05g condition was sensed by the guidance system. The crew started the system manually as prescribed by switching to the back-up position.

The entry monitor system is designed to start automatically when 0.05g is sensed by the system accelerometer. When this sensing occurs, the 0.05g light should come on, the scroll should begin to drive, and the range-to-go counter should begin to count down. The crew reported the light failure but were unable to verify whether or not the scroll or counter responded before the switch was manually changed to the backup mode.

The failure had to be in the light, in the 0.05g sensing mechanism, or in the mode switch, mode switching could also have been premature.

An enlarged photograph of the scroll was examined in detail to determine if the scroll started properly. While no abnormal indications were observed, the interpretation of these data is not conclusive.

A complete functional test was performed and the flight problem could not be duplicated. The system was cold soaked for 7 hours at 30° F. While the system was slowly warming up, continuous functional

tests were being performed to determine if thermal gradients could have caused the problem. The system operated normally throughout all tests.

Following verification of the light and sensing circuit, the mode switch was examined in detail. Tests were performed to determine contact resistance, and the switch was examined by X-ray for conductive contaminants and by dissection for nonconductive contaminants. No evidence of any switch problems was indicated.

The extensive testing and analyses and the consistency with which the postflight test data repeated preflight acceptance test results indicate the problem was most likely caused either by the Command Module Pilot responding too quickly to the 0.05g light not coming on or by an intermittent hardware failure that cleared itself during entry.

Based on these findings, a change is not warranted to existing procedures or hardware on future flights.

This anomaly is closed.

14.1.6 Gas Leak in Apex Cover Jettison System

During postflight inspection, it was discovered that propellant gas had leaked from the gusset-4 breech assembly, which is a part of the apex cover jettison system (fig. 14-7). A hole was burned through the aluminum gusset cover plate (fig. 14-8), and the fiberglass pilot parachute mortar cover on the parachute side of the gusset was charred but not penetrated. The leakage occurred at the breech-plenum interface (fig. 14-9). The breech and plenum are bolted male and female parts which are sealed with a large O-ring backed up with a Teflon ring, as shown in figure 14-7. During operation, the breech pressure reaches approximately 14 000 psi and the gas temperature exceeds 2000° F. The O-ring and backup ring were burned through and the metal parts were eroded by the hot gas at the leak path. The system is completely redundant in that either thruster system will effect apex cover jettison. No evidence of gas leakage existed on the previous firings of 56 units.

The possible causes of the gas leakage include:

- a. Out of tolerance parts - Measurement of the failed parts indicate acceptable dimensions of the metal parts.
- b. Damaged O-rings - The 21 000-psi static proof-pressure test was successful.
- c. Gap in backup ring - The installation procedure specifies the backup ring may be trimmed on assembly to meet installation requirements,

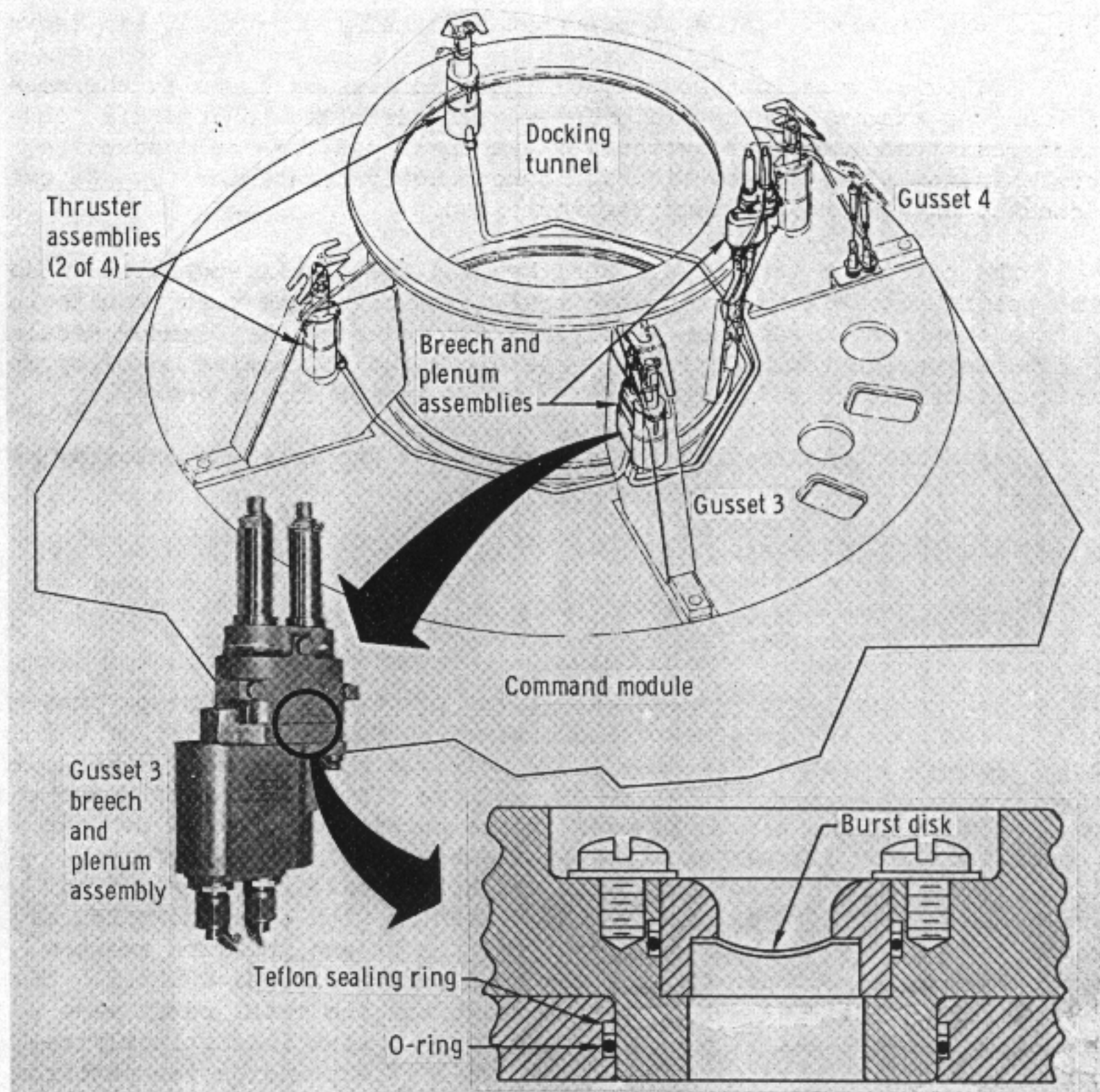

Figure 14-7.- Apex cover jettison system.

but does not specify any dimensional control over the scarf joint. Since the gap portion was burned away, a gap in the backup ring could have caused the problem.

Material and dimensional controls and improvement of assembly procedures will minimize the possibility of gas leakage without necessitating a design change. However, to protect against the possibility of leaking gas with the existing design, a thermal barrier of polyimide

NASA-S-70-5848

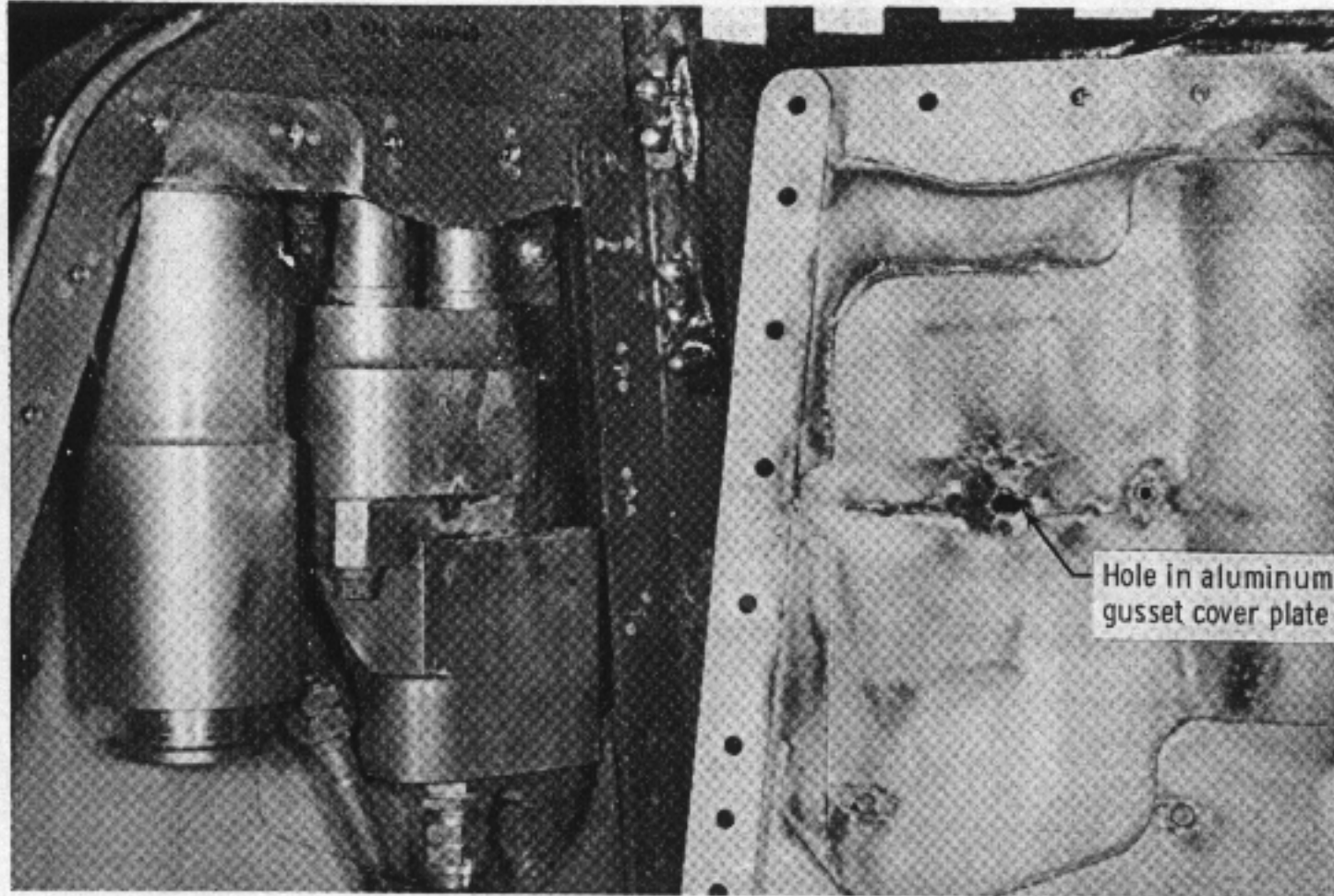

Figure 14-8.- Damage from apex jettison thruster.

NASA-S-70-5849

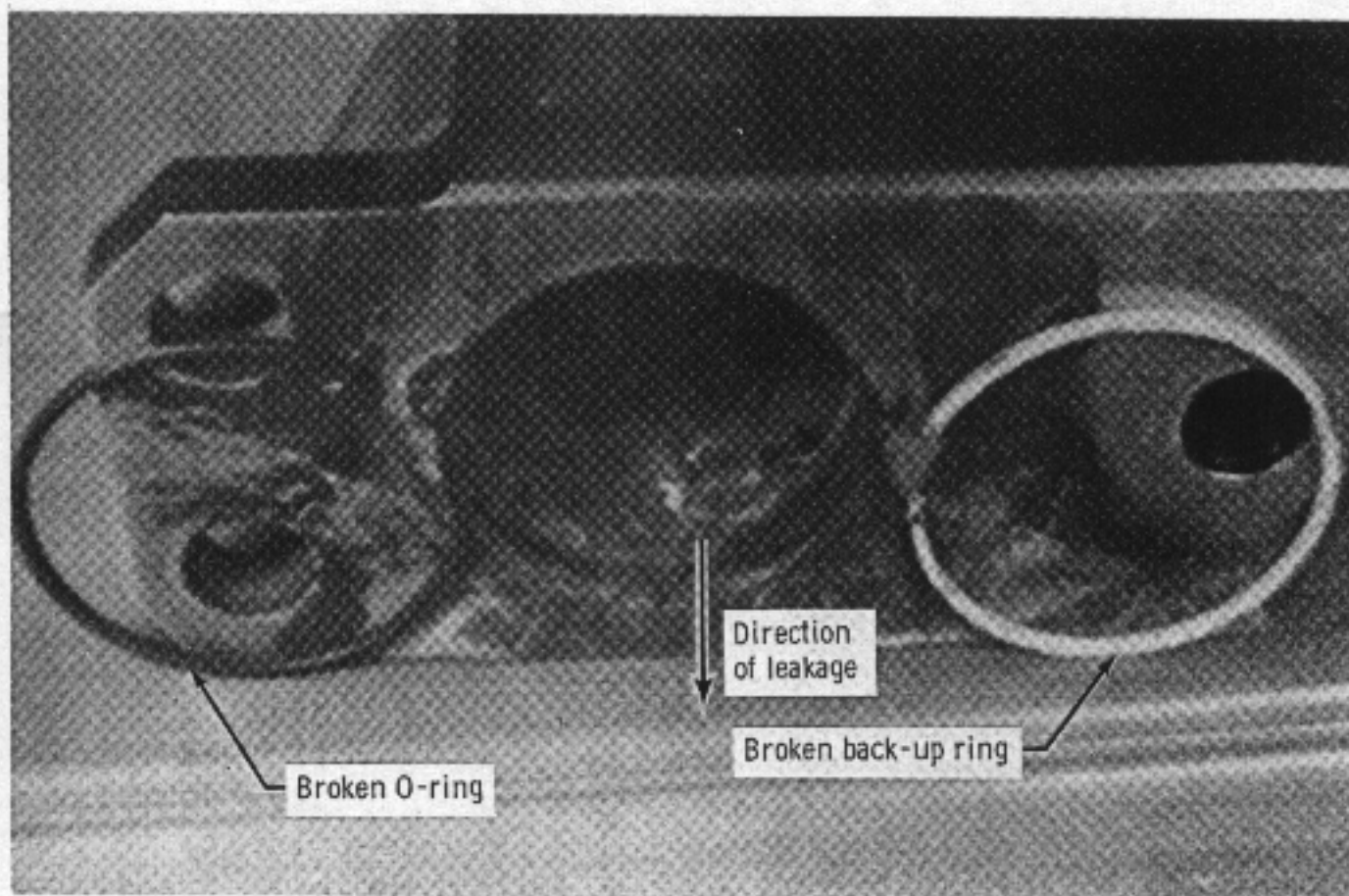

Figure 14-9.- Plenum side of breech-plenum interface.

sheet (fig. 14-10) will be applied to the interior of the breech plenum area on future spacecraft. The protection provided by the polyimide has been proof-tested by firing the assembly without the O-ring, simulating a worst-case condition.

This anomaly is closed.

NASA-S-70-5850

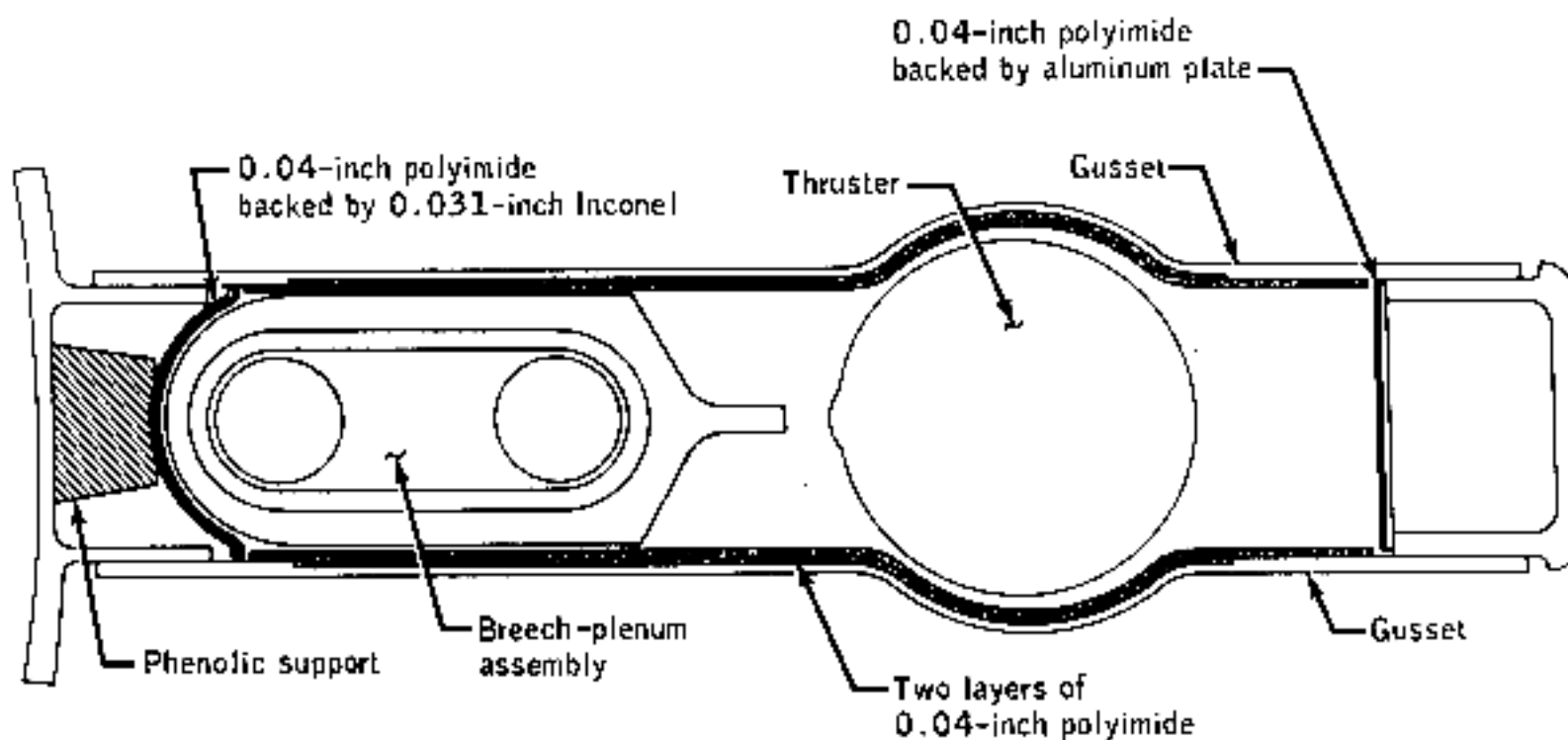

Figure 14-10.- Tunnel gusset protection.

14.1.7 Reaction Control Isolation Valve Failure

During postflight decontamination of the command module reaction control system, the system 1 fuel isolation valve was found open when it should have been closed. All other propellant isolation valves were in the closed position. The subsequent failure investigation revealed that the lead from the fuel valve closing coil was wired to an unused pin on a terminal board instead of to the proper pin. X-rays of the terminal board and closeout photographs indicate the miswiring occurred during initial installation.

The miswired valve (fig. 14-11) passed the functional checks during buildup and checkout because, even with the closing coil lead completely disconnected, the valve can be closed through an inductive coupling with the oxidizer-valve closing coil. That is, a reverse-polarity voltage can be generated in the oxidizer valve opening coil through a "transformer"

NASA-S-70-5851

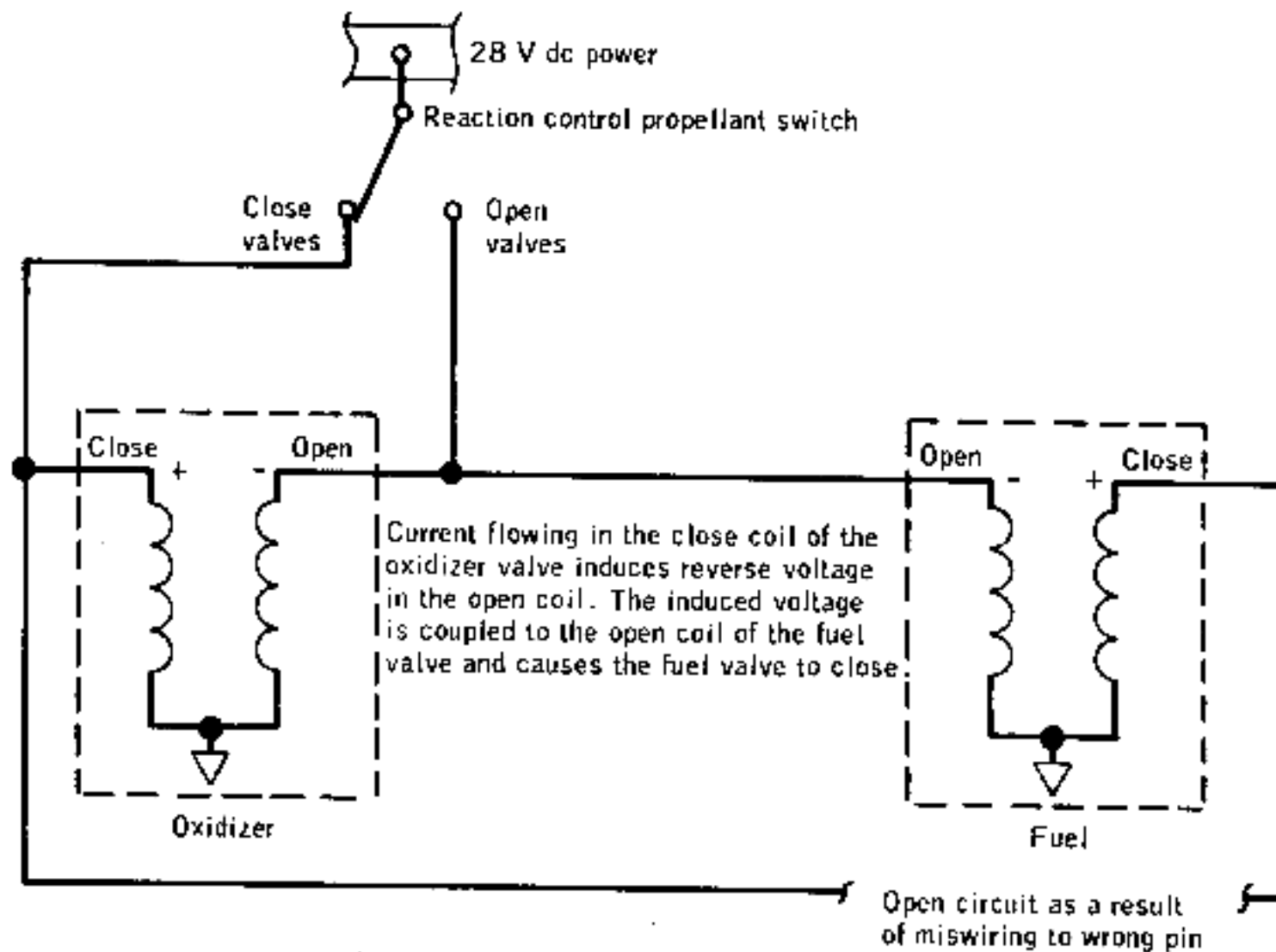

Figure 14-11.- Isolation valve circuit.

action. This voltage is applied to the fuel valve opening coil where it induces a magnetic field flux that closes the fuel valve. With 28 volts or more on the spacecraft bus, this phenomenon was consistently repeatable. With 24 to 28 volts on the bus, the valve would occasionally close, and with less than 24 volts, the valve would not close. Since preflight testing is accomplished at 28 volts, the functional tests did not disclose the miswiring. During the mission, the voltage was such that the valve did not close when commanded and therefore was found open after the flight.

Certain components are wired into the spacecraft wiring harness by inserting crimped, pinned ends of the wiring into terminal boards of the spacecraft harness. In many cases, this wiring is part of closeout installations and circuit verification can only be accomplished through functional checks of the component. This anomaly has pointed out the fact that circuits verified in this manner must be analyzed to determine if functional checks provide an adequate verification. All circuits have been analyzed with the result that the service module and command module reaction control system propellant isolation valves are the only components which require additional testing. Resistance checks will be

performed on all future spacecraft to prove that the isolation valves are properly wired.

This anomaly is closed.

14.1.8 Potable Water Quantity Fluctuations

The potable water quantity measurement fluctuated briefly on two occasions during the mission. At about 23 hours, the reading decreased from 98 to 79 percent for about 5 minutes and then returned to a normal reading of approximately 102 percent. Another fluctuation was noted at about 37 hours, at which time the reading decreased from its upper limit to 83.5 percent. The reading then returned to the upper limit in a period of 7 seconds.

Preflight fluctuations of from 2 to 6 percent near the full level were observed once during the countdown demonstration test, and a possible earlier fluctuation of about 4 percent at the half-full level was noted during the flight readiness test.

This transducer has operated erratically on two previous missions. Testing after Apollo 8 traced the failure during that mission to moisture contamination within the transducer. Similar fluctuations noted during Apollo 12 were traced to a minute quantity of undetermined contamination on the surface of the resistance wafer. Characteristically, the signal level decreased first to indicate an increase in the resistance but returned to more normal readings as the wafer cleaned itself. Disassembly of the Apollo 13 transducer and water tank did not produce evidence of either contamination or corrosion. The spacecraft wiring which could have produced the problem was checked and no intermittents were found.

The measurement is not essential for flight safety or mission success. The potable water tank is continually refilled with fuel cell product water, and when the potable water tank is full, fuel cell product water is automatically diverted to the waste water tank, which is periodically dumped overboard. Water from the potable water tank is used mainly for drinking and food reconstitution. Since fuel cell water generation rates can be computed from power generation levels and since potable water usage rates can be estimated with reasonable accuracy, the quantity of water in the potable water tank can be determined with acceptable accuracy without the quantity measurement.

This anomaly is closed.

14.1.9 Suit Pressure Transducer Failure

During launch the suit pressure transducer reading remained consistent with cabin pressure until 00:02:45, then suddenly dropped from 6.7 to 5.7 psia coincidentally with S-II engine ignition (fig. 14-12). The difference between the two measurements decreased to only 0.2 by 1-1/2 hours, when the cabin reached its nominal regulated pressure of 5.0 psia. For this shirtsleeve mode, the suit and cabin pressure readings should be nearly equal. During normal variations in the command module cabin pressure, the suit pressure measurement responded sluggishly and indicated as much as 1 psi low. Subsequently, the measurement output decayed and remained in the 4.1 to 4.3 psia range for a cabin pressure of 5.0 psia until system deactivation at about 59 hours (fig. 14-12).

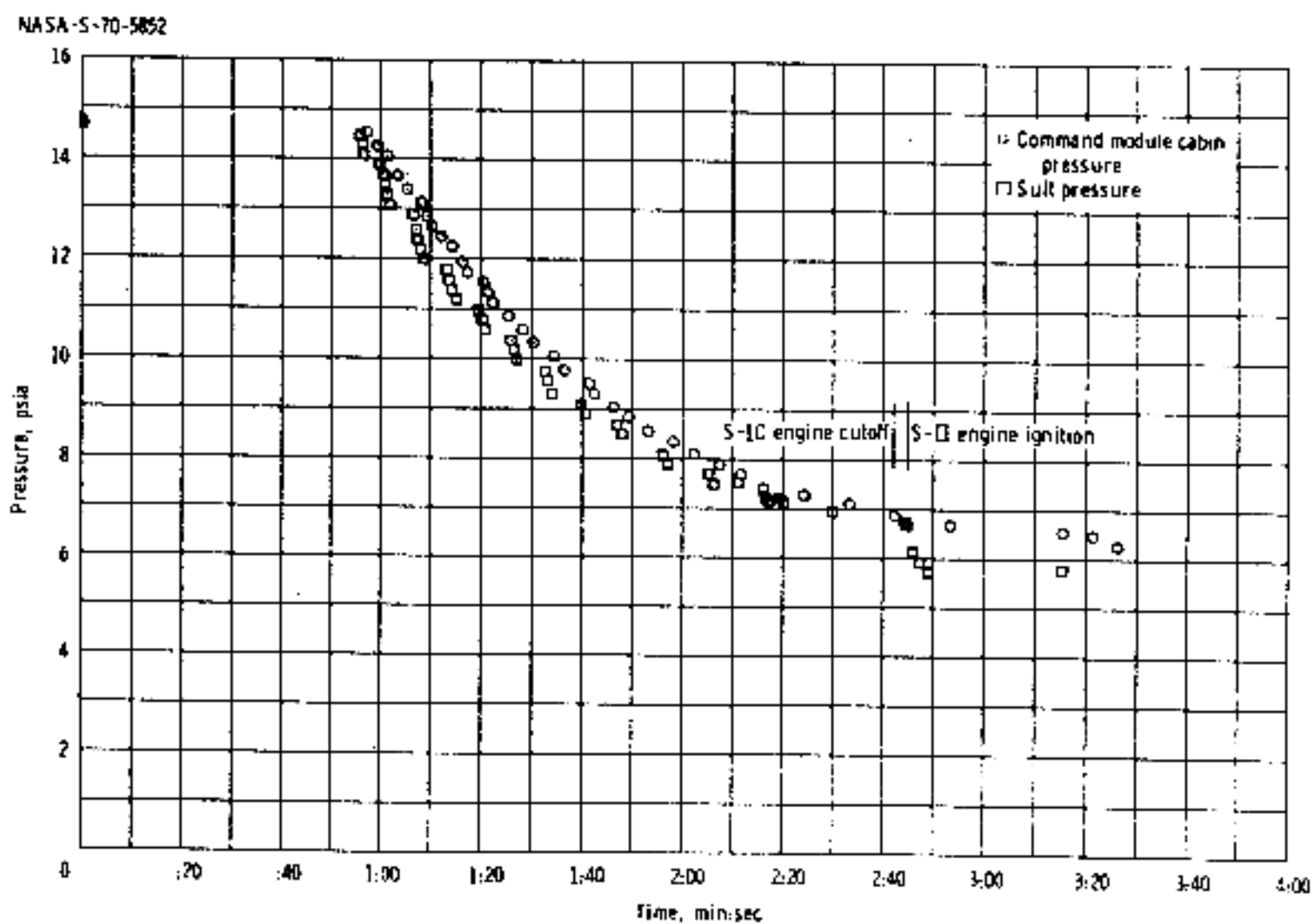

(a) Lift-off through 4 minutes.

Figure 14-12.- Suit and cabin pressure.

NASA-S-70-5853

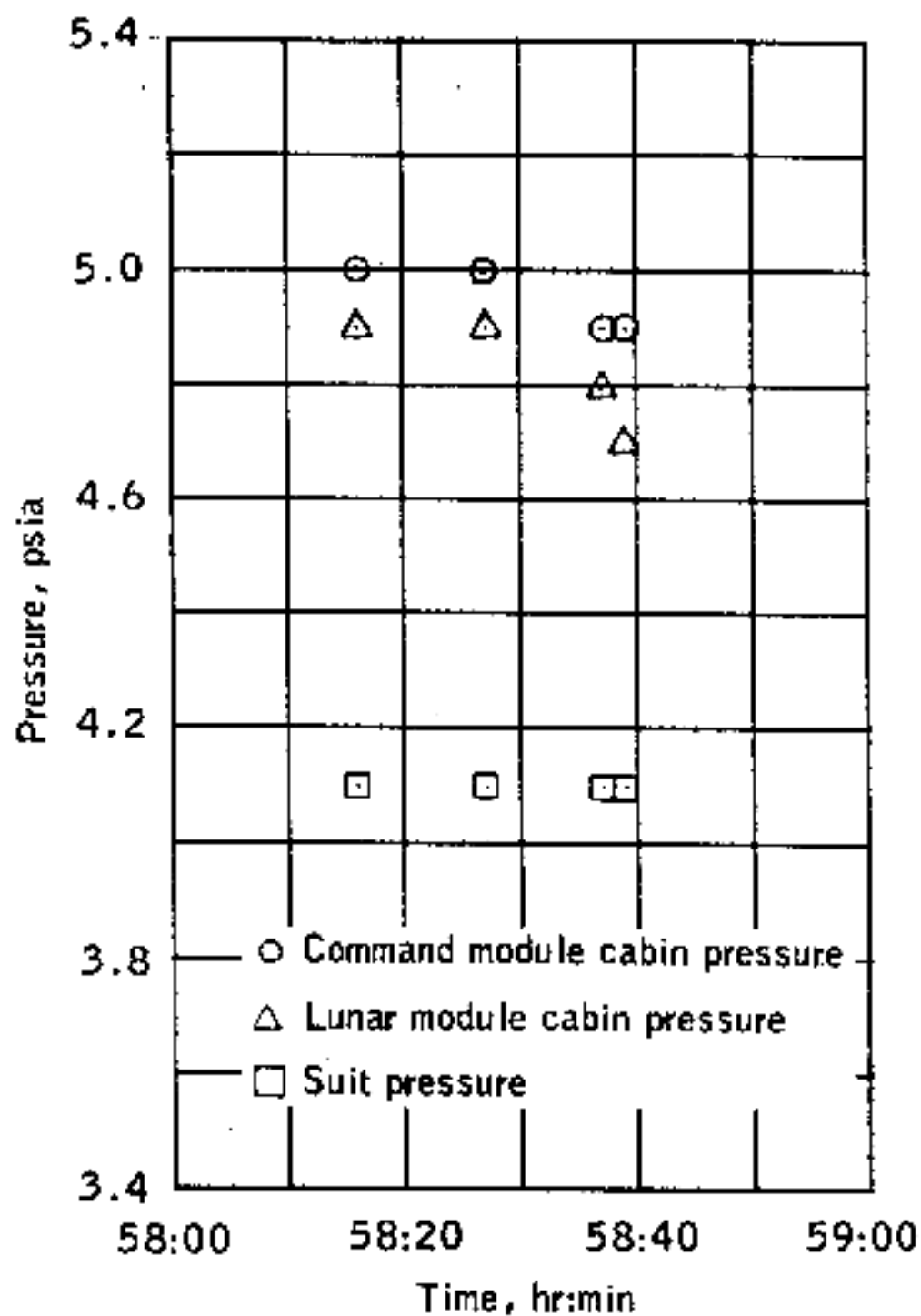

(b) 58 through 59 hours.

Figure 14-12.- Continued.

During periods when the lunar module and the command module cabins were interconnected, the lunar module and command module cabin pressure readings were approximately equal, verifying the operation of the command module cabin pressure transducers.

NASA-5-70-5854

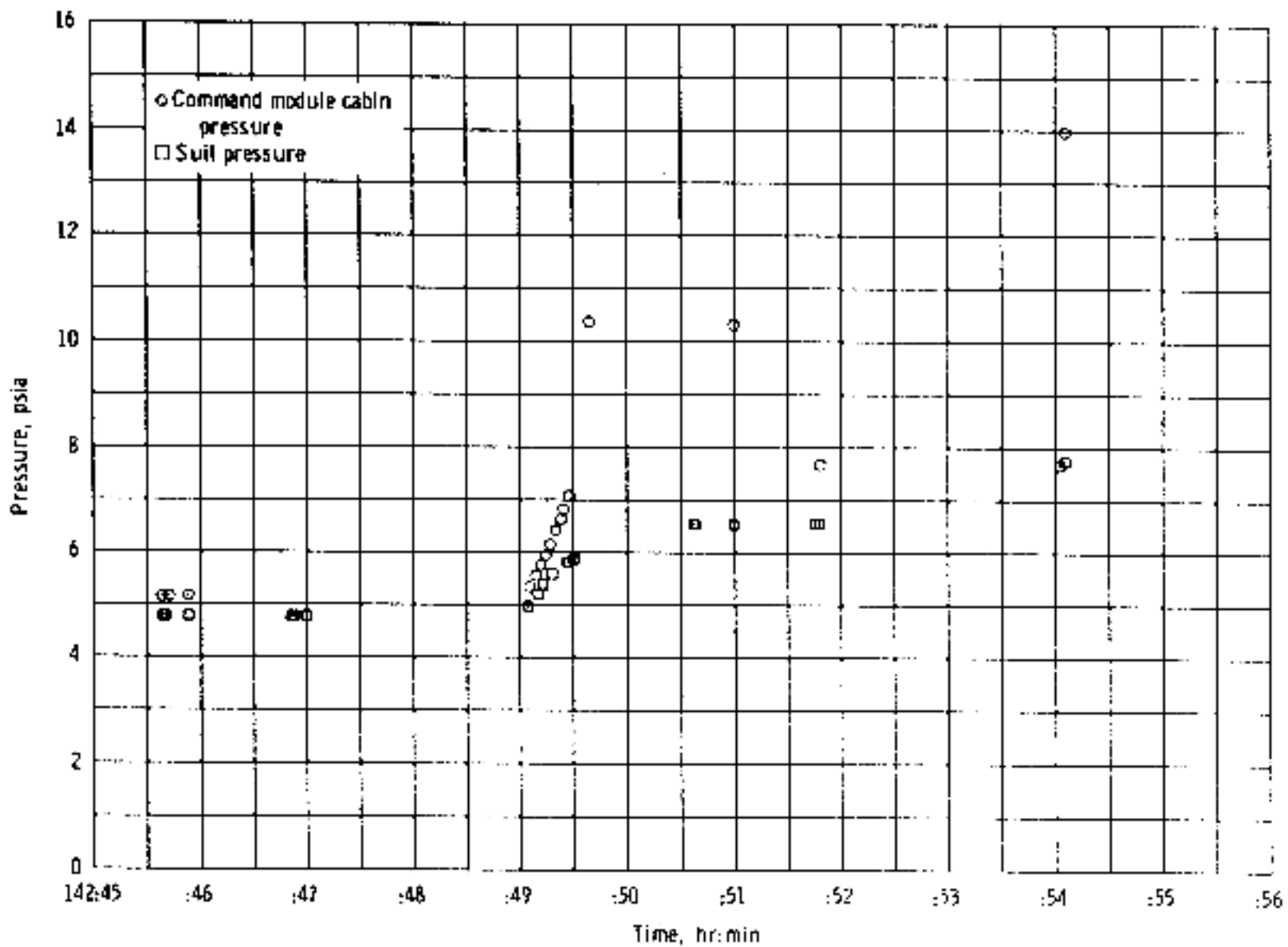

(c) 142:45 through 142:56 hours.

Figure 14-12.- Concluded.

The suit measurement indicated correctly during the brief instrumentation power-up periods at 102 and 123 hours. However, just prior to entry, the suit indication was approximately 0.3 psi lower than cabin pressure but increased to 7.7 psia when the cabin pressure was reading 13.9 psia just prior to landing.

This transducer also behaved erratically on Apollo 12. Postflight analysis of both the Apollo 12 and Apollo 13 transducers determined the cause to be internal contamination from electroless nickel plating particles.

The transducer is a variable reluctance instrument actuated by differential pressure applied across a twisted Bourdon tube. The housing, including the cavity containing the Bourdon tube and the variable reluctance elements, is nickel plated. The Bourdon tube-variable reluctance

assembly and the sense port fitting are soldered in place. Inspection of the failed units indicates that the flaking occurs adjacent to the solder.

The most probable cause of the problem is poor plating adhesion to the aluminum base metal. Differential expansion between the solder and the aluminum may cause the plating to crack. Moisture from the environmental control system suit loop could then penetrate the plating, corrode the aluminum base metal and cause the plating to peel and flake. The nickel flakes could then enter the air gap of the variable reluctance elements and affect the measurement.

Inspection also revealed that both the cabin and suit loop pressure transducers contained various contaminants identified as solder flux, glass beads (0.04 mm diameter), and fibers from the wipers used in the transducer manufacturer's clean room; all of which could potentially affect the transducer operation.

To assure that one of the pressure transducers is operative, the Apollo 14 cabin pressure transducer will be disassembled, the plating will be inspected and the instrument will be cleaned, reassembled and installed.

For Apollo 15 and subsequent, the suit and cabin pressure transducers will be disassembled and cleaned. The plating will be inspected for cracking or flaking and the units will be reassembled. The suit pressure transducers will be reassembled without soldering.

This anomaly is closed.

14.1.10 Gas Leak in Electrical Circuit Interrupter

During postflight inspection of the command module, propellant gas was noted to have escaped from the left-hand electrical circuit interrupter, mounted in the lower equipment bay, and deposited soot on adjacent equipment. The right-hand circuit interrupter showed no evidence of a gas leakage. The removed breech, showing the displaced O-ring and crushed attenuator block, is shown in figure 14-13.

The two interrupters open the electrical circuits about 30 milliseconds before the wires are severed by the command module/service module umbilical guillotine. As illustrated in the figure, a cam fork is moved by a piston, which is operated by propellant gas from redundant cartridges, to function a lift plate. Motion of this plate disconnects the male and female portions of electrical connectors located, respectively, in the lift plate and in the base plate of the interrupter. At the completion of the stroke, the fork is brought to rest by impacting and crushing an aluminum block mounted on the interrupter housing.

NASA-S-70-5855

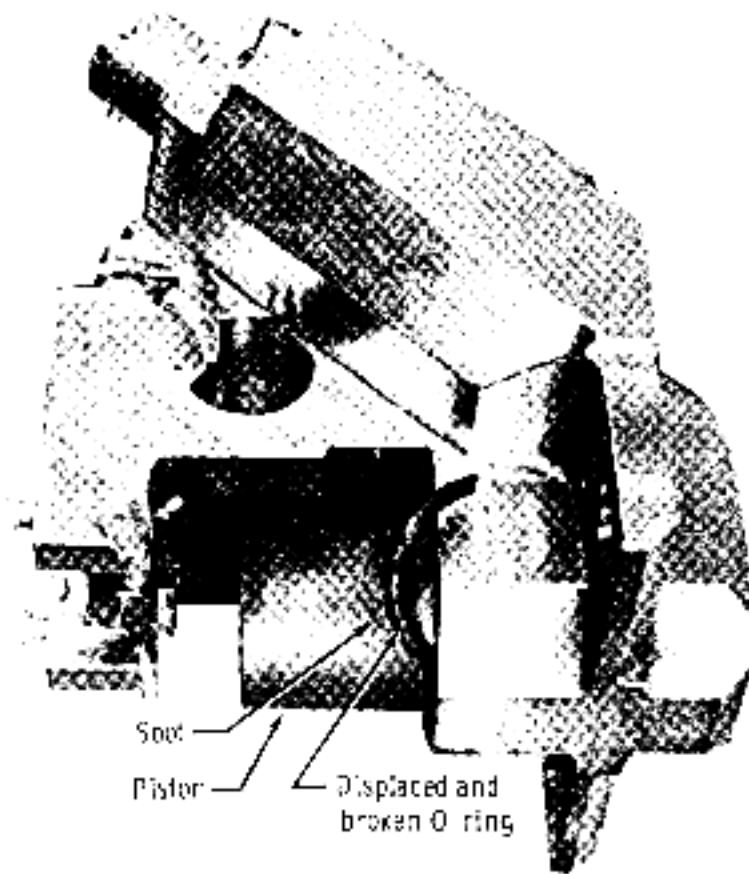
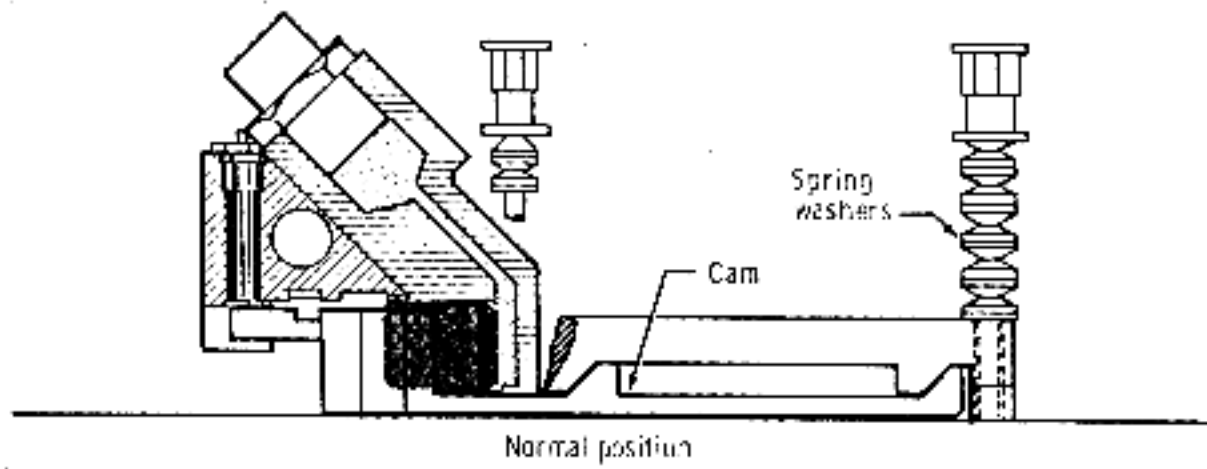

Actuation mechanism (extended)

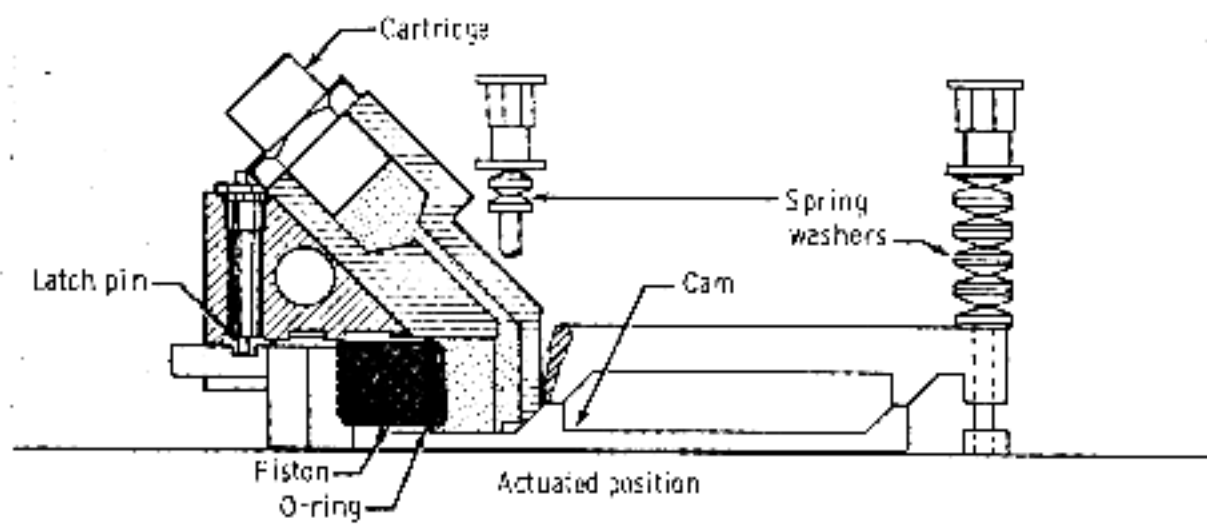

Figure 14-13.- Circuit interrupter.

The worse-case tolerance buildup is when the fork contacts the attenuator block and the piston O-ring is 0.075 inch from entering the chamfer in the breech assembly. The O-ring enters this chamfer when the block has been crushed about 94 percent, at which point an O-ring displacement and accompanying gas escape could be expected. The factors which affect the degree of attenuator crushing are generally uncontrollable within narrow limits and include:

- a. Sliding friction of the many electrical contact pins, the several camming and fork-to-plate surfaces, and the piston
- b. Forces exerted by the springs, which hold the lift and base plates together in the assembled position
- c. Propellant gas pressure and the simultaneous increase of pressure in the two breeches and the plenum
- d. Simultaneous occurrence of the electrical firing signals to the two cartridges
- e. Physical properties of the attenuator block.

Based upon an analysis of the interrupter design, its location, and its relationship to adjacent equipment, it is concluded that gas will not escape prior to the completion of the deadfacing function and that, should such escape occur, the gas will not adversely affect any other components. Therefore, no hardware modification is necessary.

This anomaly is closed.

14.2 LUNAR MODULE

14.2.1 Abnormal Supercritical Helium Pressure Rise

During the initial cold-soak period following loading of supercritical helium during the Apollo 13 countdown demonstration test, the helium exhibited a pressure rise rate approximately three times greater than expected. A preflight test was devised to determine the pressure-rise rate that would exist at the time of descent engine firing for lunar descent. The predicted tank conditions at that time would be approximately 900 psia pressure and 48 pounds of helium. Normal procedures were not used to reach 900 psia because 100 hours would have been required and the launch schedule would have been impacted; therefore, the pressure was raised to 900 psia by flowing warm helium through the tank heat exchanger. The subsequent pressure rise rate was abnormally high at 14.9 psi/hour. The abnormality of this rate was confirmed by repeating the test on two other

helium tanks, one at the manufacturer's plant and the other at the Manned Spacecraft Center. The results indicated pressure rise rates of 8.8 and 8.7 psi/hour, respectively.

The heat-leak test during the countdown demonstration indicated a normal rise rate of 7.9 psi/hour at 640 psia, whereas the special test showed an abnormal rise rate of 14.9 psi/hour above 900 psia. At some helium temperature equivalent to a pressure between 640 and 900 psia, the rise-rate characteristics would increase in the manner exhibited during the countdown demonstration test. Extrapolating these results to the flight conditions, it was determined that the helium tank was fully capable of supporting a lunar landing timeline, and the decision was made to proceed with the flight using the existing tank.

The prelaunch-standby rise rate was a normal 7.8 psi/hour. During flight, the zero-g rise rate of 7 psi/hour was slightly higher than expected, but still satisfactory. Following the first descent engine firing at 61-1/2 hours, the rise rate increased to 10.5 psi/hour, rather than returning to its normal value, as shown in figure 14-14. After the second firing at 79-1/2 hours, the rise rate again increased, this time to approximately 33 psi/hour until about 109 hours, when the helium-tank burst disc ruptured at 1937 psia, as it should have and vented the remaining helium overboard.

The helium tank is a double-walled titanium pressure vessel, with 173 layers of aluminized Mylar insulation between the two shells. The annular region is evacuated to a level of 10^{-7} torr during the manufacturing process.

The most likely cause of the anomaly is a tank-insulation degradation which would result in increased heat conduction to the helium. The insulating characteristics of the annular vacuum in tank was most likely degraded by the introduction of a contaminant (probably hydrogen) in extremely small concentrations (approximately 10^{-6} pounds). These contaminants when vaporized can exponentially increase the thermal conductivity in proportion to their vapor pressure, as indicated by special tests. While loading helium into the tank, the contaminants would freeze upon the inner shell. In the frozen state, the pressure of the contaminant is too low to significantly affect the thermal conductivity. However, the flow check which preceded the cold-soak operation would vaporize the contaminants in the vicinity of the heat exchanger lines which pass through the annulus. The subsequent increase in thermal conductivity could cause the abnormally high pressure-rise rate observed during the cold soak. These vapors would slowly condense on the cold (10° R) inner wall, resulting in the pressure rise rate dropping to the nominal level, as was observed. The rise rate would remain normal until the helium temperature increased above the vaporization temperature of the contaminant.

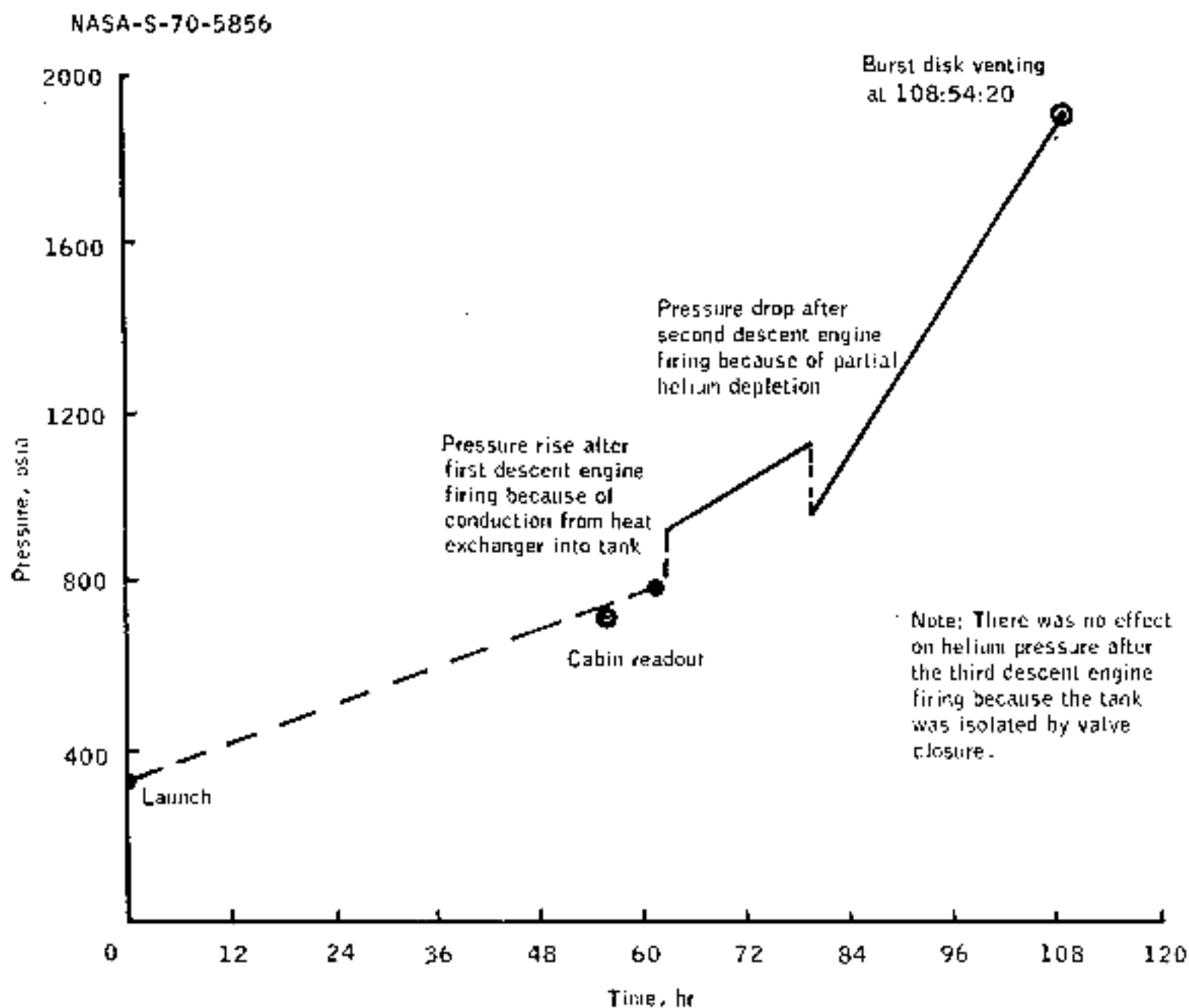

Figure 14-14.- Inflight profile of supercritical helium tank pressure.

A screening test was devised for all future flight tanks to supplement normal helium tank testing. The purpose of this test is to determine the pressure rise rate for a wide range of helium temperatures from approximately 9° to 123° R. For a perfect tank, the steady-state rise rate should remain at approximately 8 psi/hour over the entire range of temperatures. The Apollo 14, 15, and 16 tanks have been subjected to the screening test, and each exhibit the same phenomena observed during Apollo 13, but to a lesser degree. For new tanks, the manufacturer will periodically analyze the gases removed from the vacuum jacket during pump down for possible contaminants. The pressure in the jacket will be measured 2 or 3 weeks after pumpdown to verify vacuum integrity.

This anomaly is closed.

14.2.2 Abnormal Descent Stage Noise

At 97 hours 14 minutes, the crew reported a thumping noise and snowflakes venting from quadrant 4 of the lunar module descent stage (fig. 14-15). All four descent batteries experienced current transients at 97:13:53 for about 2 seconds, with corresponding drops in dc bus voltage (fig. 14-16). Also, the water glycol pressure differential for the heat transport system decreased momentarily, indicating that the glycol pump momentarily slowed down.

NASA-5-70-5857

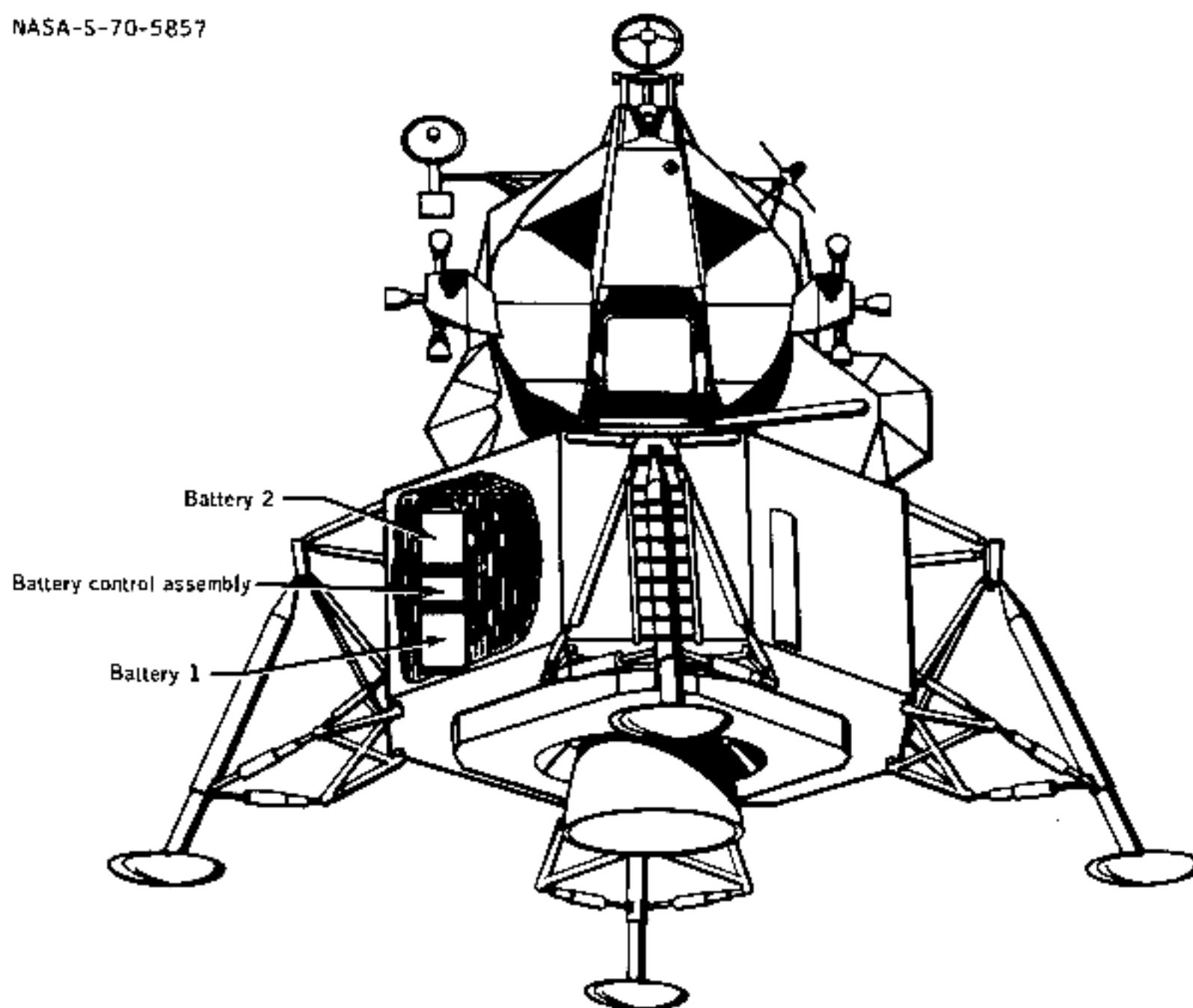

Figure 14-15.- Descent stage battery location.

NASA-S-70-5858

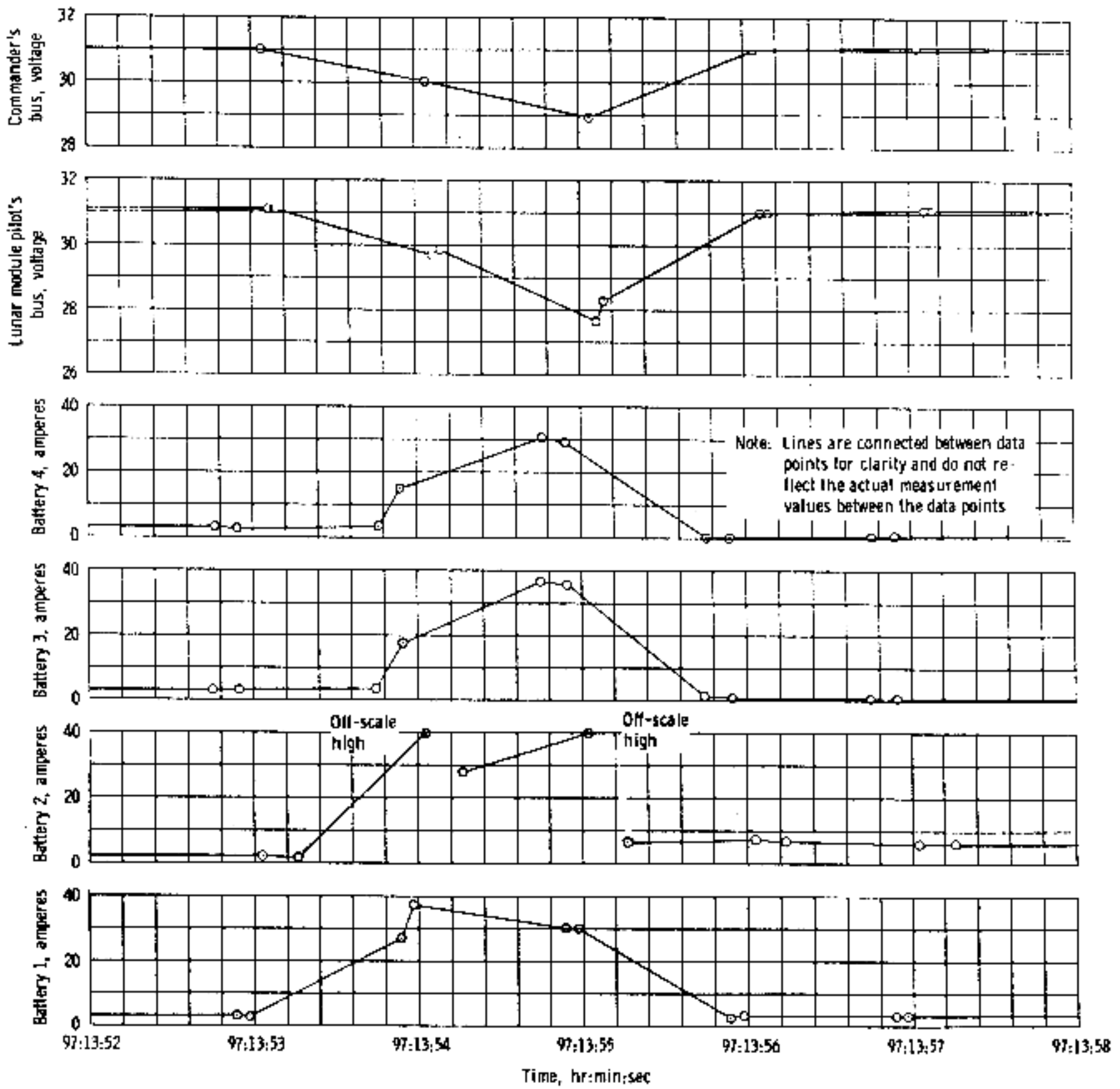

Figure 14-16.- Battery electrical transients.

The thumping noise occurred at about the same time as the current spikes. The current spikes show that a momentary short circuit existed in the Lunar-Module-Pilot side of the dc electrical system, which includes descent batteries 1 and 2 (fig. 14-16). The current surge was not of sufficient duration either to open the balance-load cross-tie circuit breakers, to display a reverse current indication, or to trip a battery-off relay as a result of an overcurrent condition.

The data show that descent battery 2 experienced at least a 60-ampere current surge. This condition could have been a reverse current into the battery, since the instrumentation system does not indicate the direction of current. Immediately after the current surges, battery 1 current returned to its original value while battery 2 provided about 60 percent of the total current load. After sustaining a surge load, the battery terminal voltage normally increases for a short period of time. Since battery 2 experienced the highest surge, it should have temporarily assumed the most load. Within 10 minutes all batteries were properly sharing the current load, and no subsequent abnormal performance was observed. At 99:51:09, battery 2 gave an indication of a battery malfunction, discussed in more detail in the next section.

Evidence indicates that battery 2 may have experienced an electrical fault of some type. The most probable condition is electrolyte leaking from one or more cells and bridging the high-voltage or low-voltage terminal to the battery case (fig. 14-17). This bridging results in water electrolysis and subsequent ignition of the hydrogen and oxygen so generated. The accompanying "explosion" would then blow off or rupture the seal of the battery lid and cause both a thump and venting of the free liquids in the battery case, resulting in "snowflakes."

Postflight tests have shown the following:

- a. Electrolyte can leak past the Teflon retention screens installed in each cell to prevent leakage.
- b. The descent battery cells contain an excessive amount of free electrolyte.
- c. The potting does not adhere to the battery case, consequently, any free electrolyte can readily penetrate the interface between the potting and the case and bridge between the terminals and case.
- d. Once an electrolyte bridge is formed, electrolysis will produce hydrogen and oxygen gas.
- e. A bridge at the positive terminal can produce a current surge of as much as 150 amperes.

For Apollo 14 and subsequent missions, the descent batteries will be modified to minimize the hazards associated with electrolyte leakage.

NASA-S-70-5859

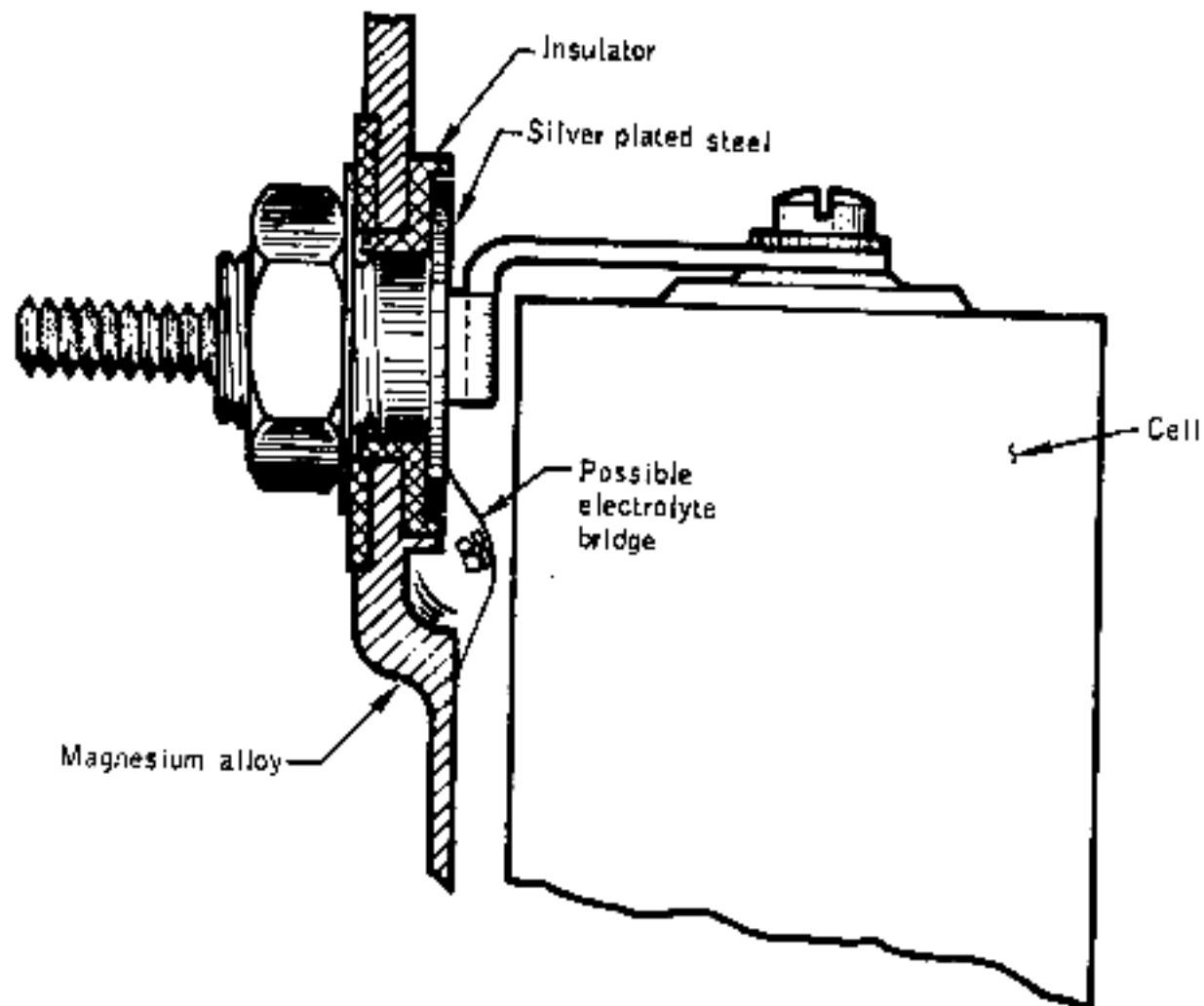

Figure 14-17.- Descent battery terminal configuration.

The battery potting will be improved to prevent electrolyte bridging between the battery terminals and case. These improvements include coating the inside of the battery case with epoxy paint before the battery is assembled and changing the potting material used at the ends of the case to a material which has better adhesion characteristics. Also, the cell chimneys will be manifolded together and to the case vent-valve with plastic tubing.

In addition, tests are being performed to determine if the quantity of free electrolyte in each cell can be reduced. Preliminary results indicate a reduction of from 360 to 340 cc per cell is possible.

The designs of other Apollo batteries have been reevaluated, and all are considered safe except the lunar module ascent batteries and the lunar surface drill battery. The ascent batteries and a new battery to be installed in subsequent service modules will receive the same corrective action applied to the descent battery. The lunar surface drill battery, which previously was unpotted, will be potted.

This anomaly is closed.

14.2.3 Descent Battery 2 Malfunction Light On

The battery malfunction light illuminated at about 100 hours with a corresponding master alarm. The malfunction, isolated to battery 2, could have been caused by an overcurrent, a reverse-current condition, an over-temperature condition, or possibly an erroneous indication. The logic for these malfunction conditions is shown in figure 14-18.

NASA-5-70-5860

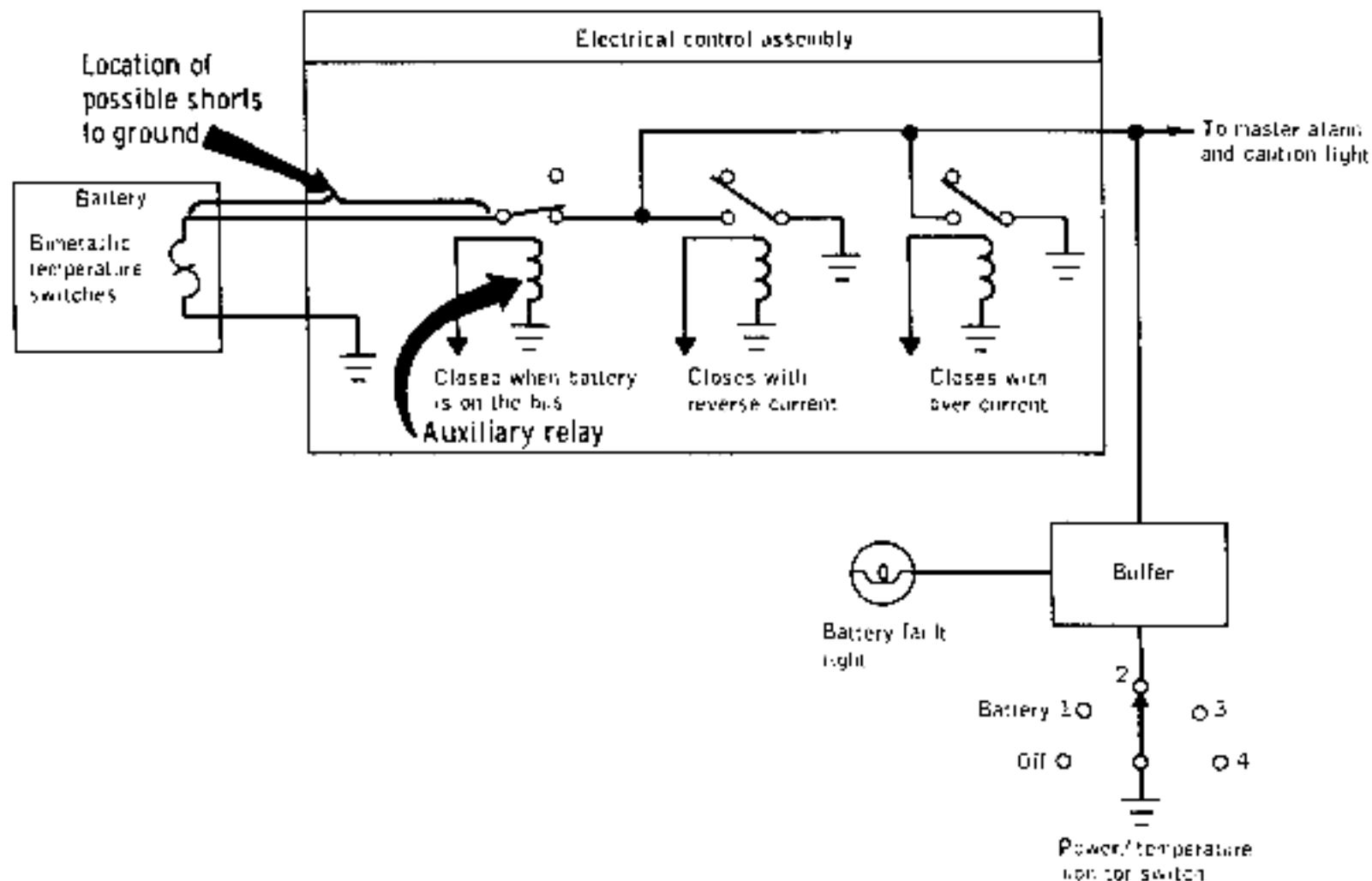

Figure 14-18.- Battery 2 malfunction circuit.

A battery overcurrent can be ruled out because automatic removal of the battery from the bus would have occurred.

A reverse-current condition can be ruled out because, if the battery is removed from and reapplied to the bus, the reverse-current circuit has a built-in delay of about 5 seconds before the reverse-current relay is again activated to illuminate the light. Battery power was removed from and replaced on the bus in flight, and the light immediately illuminated again when the battery was reconnected.

An over-temperature condition can be ruled out because, after the battery was replaced on the bus, the light remained illuminated for a brief period and then began flickering intermittently. A flickering light cannot be caused by the temperature sensing switch because of a temperature hysteresis of approximately 20° F in the switch. The water glycol loop temperature also indicated that the battery temperature was normal.

Either a short between the temperature switch wires to ground or a contamination in the auxiliary relay would actuate the light. The shorted condition could have resulted from electrolyte shorting within the battery case associated with the current surges discussed in the previous section. Contamination of the auxiliary relay has occurred in the past, and relays already packaged were not retrofitted since a false over-temperature indication can be identified as it was here.

Corrective action is being taken to prevent electrolyte shorts associated with the previously discussed battery anomaly which should eliminate this type of sensor problem in future spacecraft. No further corrective action to eliminate contamination in the auxiliary relay is required.

This anomaly is closed.

14.2.4 Ascent Oxygen Tank 2 Shutoff Valve Leak

During the flight, the pressure in the ascent stage oxygen tank 2 increased, indicating a reverse leakage through the shutoff valve from the oxygen manifold (fig. 14-19) into the tank. The leak rate, with a maximum differential pressure of 193 psi, varied from about 0.22 lb/hr (70 000 scc/hr) to zero when the tank pressure reached manifold pressure. Allowable leakage for the valve in either direction is 360 scc/hr. Pre-flight test data indicate a reverse leakage of 360 scc/hr and no excessive leaking in the forward direction.

The internal portion of three valves of this type had been replaced previously on the spacecraft because of excessive leakage through the ascent oxygen tank 1 shutoff valve. In one valve, a rolled O-ring

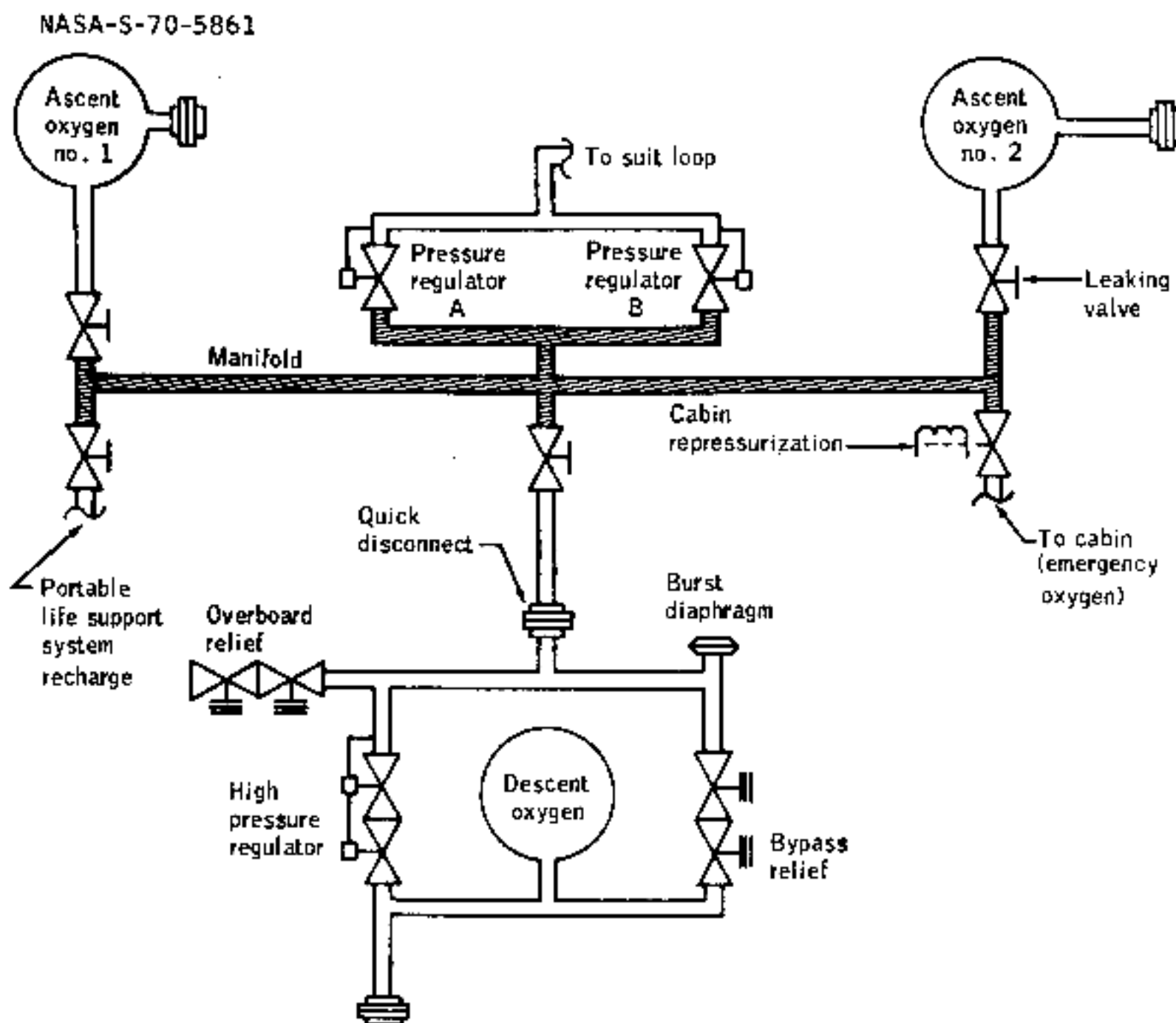

Figure 14-19.- Oxygen-supply system.

(fig. 14-20) caused the leakage. When the valve is installed, the forward O-ring can be rolled and damaged when it passes the manifold port. In the other two valves, the cause was not identified and was assumed to be contamination.

The production tolerances of the valve and bore were examined to determine if a tolerance buildup problem existed. The manufacturer's specification to which the valve was designed requires that the O-ring be subjected to a compression of between 0.0115 and 0.0225 inch, whereas the O-ring supplier recommends between 0.011 and 0.017 inch. The added

NASA-5-70-5B62

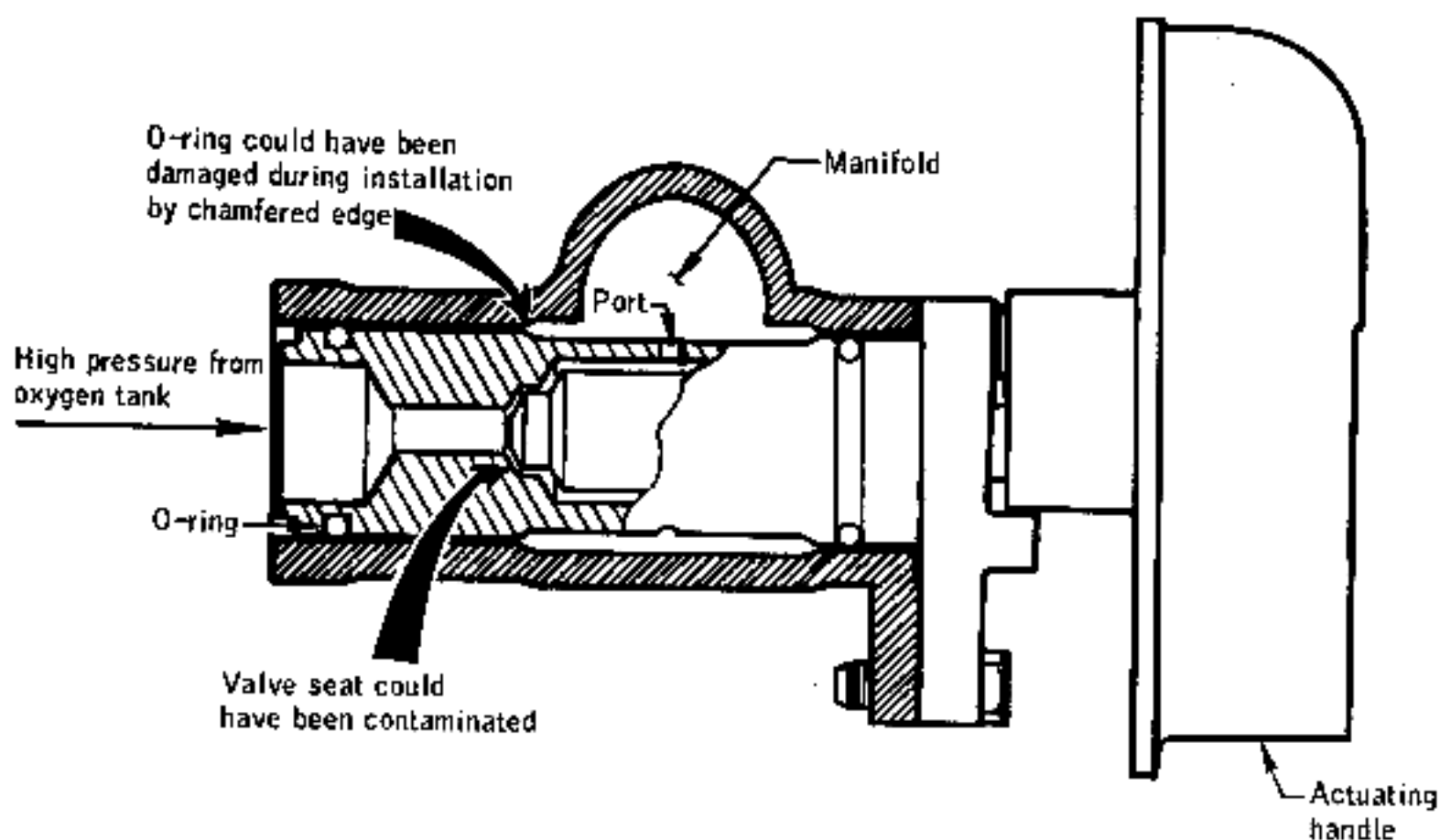

Figure 14-20.- Ascent stage tank shutoff valve.

compression allowed in the valve design would aggravate the tendency for the O-ring to roll during valve assembly.

Leak tests previously performed on the valve were inadequate, in that only reverse leakage at high pressure was determined. For future vehicles, forward and reverse leakage at both high and low pressures will be measured to detect any defective valves.

This anomaly is closed.

14.2.5 Cracked Window Shade

The left-hand window shade showed three large separations when it was first placed in the stowed position during flight (fig. 14-21). A Beta Cloth backing is stitched to the inner surface of the Aclar shade. The cracks propagated from the sewing stitch holes on the periphery of the shade. About 1/8-inch-long cracks extended from about 80 percent of the stitch holes in a direction parallel with the curl axis of the shade.

NASA-S-70-5863

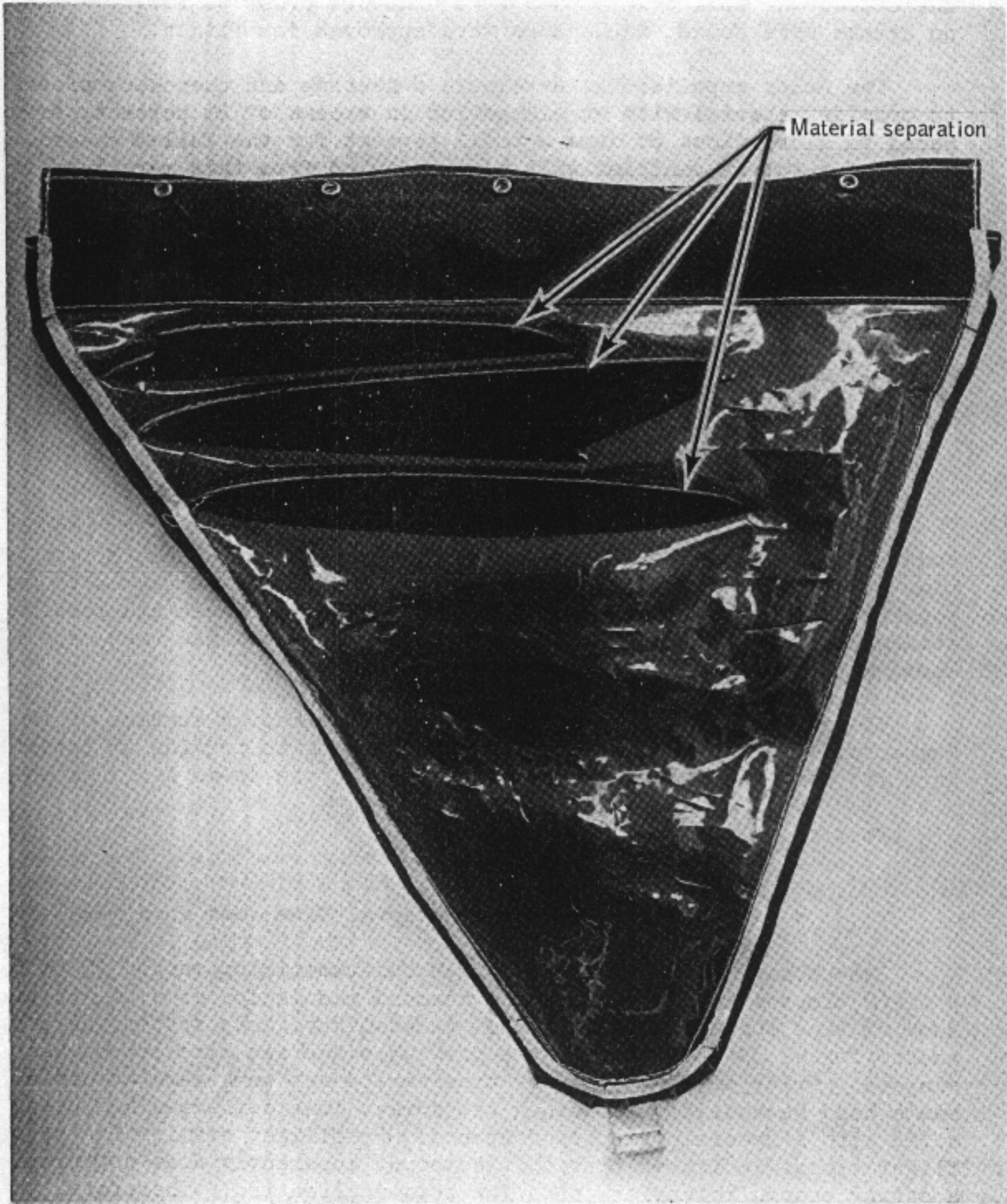

Figure 14-21.- Cracked left-hand window shade.

Cracking as a result of Aclar embrittlement has occurred before, therefore, the Apollo 13 shades were examined prior to flight. Since no cracks were found, the shades were approved for flight.

The Aclar supplier has developed a heating and quenching process to provide material with an elongation in excess of 25 percent, as compared to elongations of from 6 to 12 percent for the failed shades. Shades for future vehicles will be fabricated from this more ductile material. The Aclar will be reinforced with Mylar tape before the Beta Cloth backing is stitched to the shade. The modified shades have been requalified for the next flight.

This anomaly is closed.

14.3 GOVERNMENT FURNISHED EQUIPMENT

14.3.1 Loose Lens Bumper On Lunar Module 16-mm Camera

For launch, the 16-mm camera is mounted to point through the Lunar Module Pilot's window with the 10-mm lens and bumper attached. At the time of inflight lunar module inspection, the bumper was found to have separated from the camera lens. The bumper was replaced and remained attached for the remainder of the flight. Looseness has been experienced during previous lens/bumper assemblies.

To prevent recurrence of the problem, the mating surface of the bumper will be swaged for future missions so as to provide an interference fit with the internal surface threads of the 10-mm lens assembly.

This anomaly is closed.

14.3.2 Failure of the Interval Timer Set Knob

The onboard interval timer, which has two timing ranges (0 to 6 and 0 to 60 minutes), is stowed in the command module for crew use in timing such routine functions as fuel cell purges, cryogenic system fan cycles, and so forth. A tone advises the crew when the set time period has elapsed. Prior to 55 hours, the time-period set knob came off in a crewman's hand because of a loosened set screw. The set screw had been secured with a special gripping compound. Postflight examination of other flight timers indicated that this compound apparently does not provide a strong enough retention force for this application. Therefore, the knobs on timers for future flights will be secured to the shaft with a roll pin.

This anomaly is closed.

14.3.3 Improper Nasal Spray Operation

When attempts were made to use the two nasal spray bottles in the command module medical kit, no medication could be obtained from one bottle and only two or three sprays could be obtained from the other. On previous flights, there had been a tendency for the spray to be released too fast, therefore a piece of cotton was inserted in the 9-cc bottle to hold the 3 cc of medication. Chamber tests and ambient shelf-life tests have indicated that this change was satisfactory. Those tests have also shown that, for best results, the bottle should be squeezed where the cotton is located. Postflight examination of the one returned bottle demonstrated satisfactory operation under normal gravity. The returned bottle still contained 2.5 cc of medication after five or six test sprays.

Medical kits for future flights will include nose drops packaged the same as the eye drops. This packaging has been satisfactory on previous flight for eye drops.

This anomaly is closed.

15.0 CONCLUSIONS

The Apollo 13 mission was the first in the Program requiring an emergency abort, with the Gemini VIII mission the only prior case in manned spaceflight where a flight was terminated early. The excellent performance of the lunar module systems in a backup capacity and the training of both the flight crew and ground support personnel resulted in the safe and efficient return of the crew. The following conclusions are drawn from the information contained in this report.

a. The mission was aborted because of the total loss of primary oxygen in the service module. This loss resulted from an incompatibility between switch design and preflight procedures, a condition which, when combined with an abnormal preflight detanking procedure, caused an in-flight shorting and a rapid oxidation within one of two redundant storage tanks. The oxidation then resulted in a loss of pressure integrity in the related tank and eventually in the remaining tank.

b. The concept of a backup crew was proven for the first time when 3 days prior to flight the backup Command Module Pilot was substituted for his prime-crew counterpart, who was exposed and susceptible to rubella (German measles).

c. The performance of lunar module systems demonstrated an emergency operational capability. Lunar module systems supported the crew for a period approximately twice their intended design lifetime.

d. The effectiveness of preflight crew training, especially in conjunction with ground personnel, was reflected in the skill and precision with which the crew responded to the emergency.

e. Although the mission was not a complete success, a lunar flyby mission, including three planned experiments (lightning phenomena, earth photography, and S-IVB lunar impact), was completed and information which would have otherwise been unavailable, regarding the long-term backup capability of the lunar module, was derived.

APPENDIX A - VEHICLE DESCRIPTIONS

The configuration of the Apollo 13 spacecraft and launch vehicle was nearly identical to that of Apollo 12, and the spacecraft/launch vehicle adapter and launch escape system underwent no changes. The few changes to the command and service modules and the lunar module are discussed in the following paragraphs. A discussion of the changes to the Apollo lunar surface experiments package and a listing of the spacecraft mass properties are also presented.

A.1 COMMAND AND SERVICE MODULES

The structure in the forward end of the docking tunnel was reinforced to accommodate the expected higher parachute loads due to the increased weight of the command module. In the sequential system the timing signal which disables the roll engines during service module separation was changed from a 5.5- to a 2-second interval, and a cutoff time of 25 seconds was incorporated for the translation engines instead of allowing them to fire until the propellant was depleted. These timing changes were instituted to minimize the effects of fuel slosh and to improve service-module separation characteristics. The stripline units in the high-gain antenna were changed to an improved design. A detachable filter was provided for installing over the cabin heat exchanger exhaust to assist in collection of free lunar dust after crew transfer from the lunar module. An extra urine filter, in addition to the primary and backup units, was stowed and could be used to reduce the possibility of a clogged urine transfer line. Also included was a lunar topographic camera, which could be installed in the command module hatch window for high resolution photography of the lunar surface from orbit. The camera provided a 4.5-inch film format and had an 18-inch focal length and image-motion compensation. The photographs would yield a resolution of approximately 12 feet and would include a 15-mile square area on the surface for each frame exposed.

A.2 LUNAR MODULE

The thickness of the outer-skin shielding for the forward hatch was increased from 0.004 to 0.010 inch to improve the resistance to the tearing that was noted on Apollo 12. The D-ring handle on the modularized equipment storage assembly was changed to a looped cable to simplify the deployment operation. The thermal insulation for the landing gear was modified to reduce the total insulation weight by 27.2 pounds. Both a color and a black-and-white television camera were included for increased

reliability of television coverage on the lunar surface. The primary guidance programs were modified to permit reentry into the automatic and attitude hold modes of operation after manual control was exercised; this change was incorporated to provide improved final descent capability in the event of obscuration from lunar dust. The event timer was modified so that after it counted down to zero, it would count up automatically and thus reduce crew workload during critical events. The descent propulsion system was changed to include a bypass line around the fuel/helium heat exchanger such that if the heat exchanger should freeze during venting, pressures would equalize on both sides of the heat exchanger. The sensing point for the water separator drain tank was changed from the location of the carbon dioxide sensor to a point upstream of the suit fans, thus eliminating migration of water to the carbon dioxide sensor and improving its operation. A removable flow limiter was added to the inlet for the primary lithium hydroxide cartridge to reduce the water separator speed and to minimize the possibility of condensed water in the suit. A dust filter was incorporated at the inlet of the cabin fan to reduce the amount of free lunar dust in the cabin. Redesigned water/glycol and oxygen disconnects having redundant seals were installed to improve reliability and to permit up to 5 degrees of connector misalignment. To decrease the possibility of lunar dust contamination, a brush was added for cleaning the suits before ingress, the bristles on the vacuum brush were changed from Teflon to Nylon, and a cover was added to the lunar sample tote bag.

The extravehicular mobility unit underwent several modifications to improve lunar surface capability. Scuff patches were added to the pressure garment assembly to prevent wear of the thermal/meteoroid garment caused by chaffing of the lunar boots. A device was added in the neck area of the pressure suit to provide drinking water to the crewmen during extravehicular activity. A center eyeshade was installed at the top of the extravehicular visor assembly to reduce incoming glare and to aid in dark adaptation when entering shadow. Abrasion cover gloves were included to be used over the extravehicular gloves to reduce wear and heat conduction during core drilling operations. The electrical connector on the remote control unit for the portable life support system was redesigned to permit easier engagement. The manufacturing technique for the regulator in the oxygen purge system was modified to minimize the possibility of gas leakage.

A.3 EXPERIMENT EQUIPMENT

The Apollo lunar surface experiment package stowed for Apollo 13 was similar to that for Apollo 12. However, the solar wind spectrometer, magnetometer, and suprathermal ion detector, included on Apollo 12, were

deleted from Apollo 13. A heat flow experiment and a charged particle environment detector were added for Apollo 13. The cold-cathode ion gage experiment deployed during Apollo 12 was significantly modified for Apollo 13.

The Apollo lunar surface experiments package consisted of two sub-packages as shown in figures A-1 and A-2. These were stowed in the lunar module scientific equipment bay.

NASA-5-70-5864

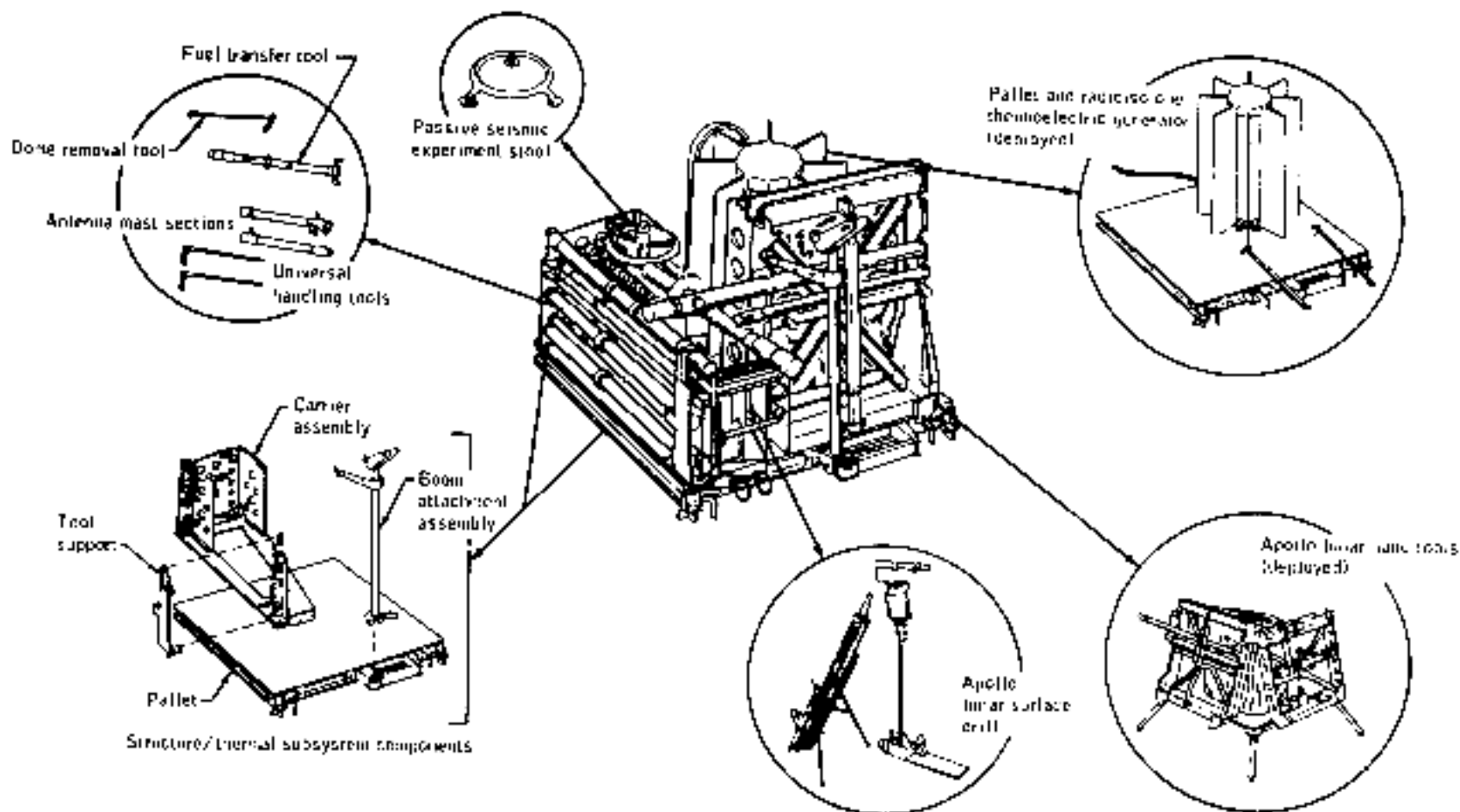

Figure A-1.- Experiment subpackage number 1.

A.3.1 Heat Flow Experiment

The heat flow experiment was designed to measure the thermal gradient of the upper 3 meters of the lunar crust and the thermal conductivity of the lunar surface materials. Lunar heat flow calculations could be based on the measurements.

The experiment consisted of an electronics package and two sensor probes which were to be placed in bore holes, predrilled by the crew using the Apollo lunar surface drill. At each end of the probe was a gradient heat sensor with heater coil, a ring sensor 10 centimeters from each end, and four thermocouples in the probe cable. The probe consisted of two 55-centimeter sections joined at a 2-inch spacing with a flexible spring.

NASA-S-70-5865

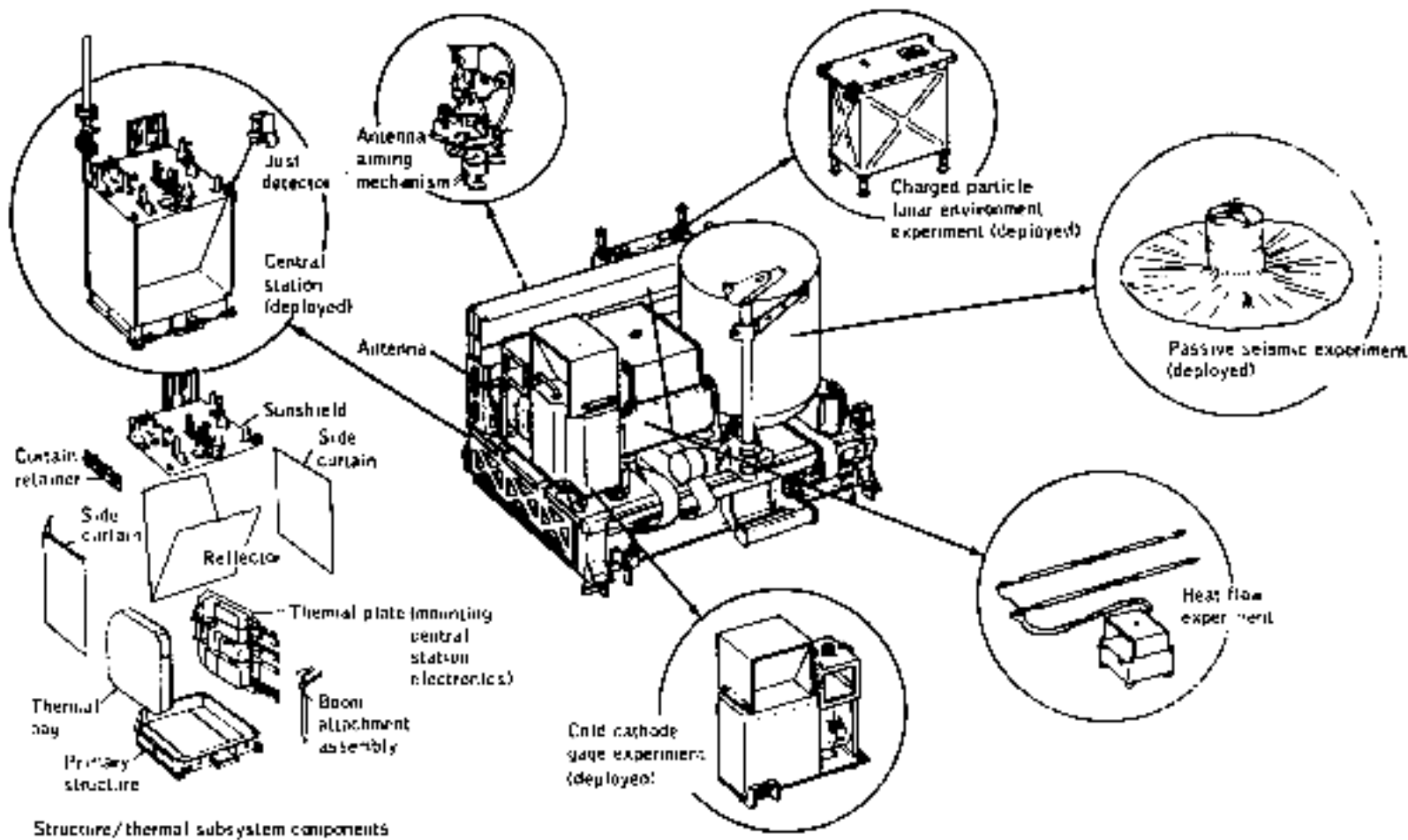

Figure A-2.- Experiment subpackage number 2.

A.3.2 Charged Particle Lunar Environment Experiment

The charged particle lunar environment experiment was designed to measure the energy of protons and electrons in the energy range of 40 to 70 electron volts. The experiment consisted of two detector/analyzer packages, each oriented for minimum exposure to the ecliptic path of the sun, one for the east-west plane and one for the north-south plane. Each of the detector packages had six particle energy detectors. A complete measurement of all energy ranges would be made every 19.4 seconds.

A.3.3 Cold Cathode Gage Experiment

The cold cathode gage experiment was designed to measure the density of the lunar atmosphere by sensing the particle density immediately around its deployed position. An electrical current would be produced in the gage proportional to particle density. Pressure of the ambient atmosphere could be calculated, based on the measurements of the density of the neutral atoms.

The experiment consisted of an electronics package with sunshield and reflector, to shade the thermal plate from the direct sunlight, and a sensor package with aperture and dust cover.

A.4 LAUNCH VEHICLE

Spray foam was used exclusively as insulation in the S-II stage to reduce weight. A fourth battery was installed in the instrument unit to extend the tracking capability to lunar distance in support of the S-IVB lunar impact experiment. Telemetry measurements in the inertial platform were added and, in some cases, were relocated to provide a more complete analysis of platform vibrations. Four wires were added to the distributor in the emergency detection system, located in the instrument unit, to provide automatic ground command capability at spacecraft separation in the event of a contingency separation.

A.5 MASS PROPERTIES

Spacecraft mass properties for the Apollo 12 mission are summarized in table A-1. These data represent the conditions as determined from postflight analyses of expendable loadings and usage during the flight. Variations in spacecraft mass properties are determined for each significant mission phase from lift-off through landing. Expendables usage is based on reported real-time and postflight data as presented in other sections of this report. The weights and centers of gravity of the individual command and service modules and of the lunar module ascent and descent stages were measured prior to flight, and the inertia values were calculated. All changes incorporated after the actual weighing were monitored, and the spacecraft mass properties were updated.

TABLE A-I.- MASS PROPERTIES

Event	Weight, lb	Center of gravity, in.			Moment of inertia, slug-ft ²			Product of inertia, slug-ft ²		
		X	Y	Z	I _{XX}	I _{YY}	I _{ZZ}	I _{XY}	I _{XZ}	I _{YZ}
Lift-off	110 252.4	847.4	2.4	3.7	67 646	1 175 539	1 175 016	2906	8 047	3711
Earth orbit insertion	102 261.2	807.4	2.6	4.1	66 770	718 686	721 213	5157	11 945	3688
Transposition and docking ^a										
Command & service modules	63 720.3	934.5	4.0	6.5	33 995	76 486	73 123	-1746	-126	3021
Lunar module	33 499.2	1237.0	-0.1	0.0	22 457	24 654	25 255	-434	95	235
Total indexed	97 219.4	1035.7	2.6	4.3	56 736	534 590	532 009	-2142	-9376	3505
First midcourse correction										
Ignition	97 081.5	1035.9	2.6	4.2	56 629	534 492	537 435	-2192	-9305	3640
Cutoff	96 851.1	1039.0	2.6	4.2	56 508	534 139	537 360	-2189	-9282	3687
Cryogenic oxygen tank incident										
Before	96 646.9	1039.7	2.6	4.2	56 321	533 499	536 766	-2239	-9244	3636
After	96 036.7	1040.7	3.0	3.9	57 248	533 927	537 251	-2269	-8493	-3709
Second midcourse correction										
Ignition	95 959.9	275.8	4.9	0.7	57 205	516 445	521 150	11517	2609	3286
Cutoff	95 647.1	379.4	5.0	0.7	57 006	513 919	516 707	11553	2651	3255
Transearth injection ^b										
Ignition	95 424.0	379.7	5.0	0.7	56 866	512 837	517 560	11375	2495	3255
Cutoff	87 456.0	394.4	5.5	0.8	52 778	431 205	437 119	9443	2222	3249
Third midcourse correction ^b										
Ignition	87 325.3	392.7	5.5	0.8	51 681	430 123	435 930	9244	2048	3215
Cutoff	87 263.3	392.9	5.5	0.8	51 642	429 353	435 169	9227	2045	3215
Fourth midcourse correction ^b										
Ignition	87 132.1	399.1	5.5	0.8	51 553	428 322	434 105	9069	1911	3191
Cutoff	87 101.5	399.2	5.5	0.8	51 538	428 219	433 990	9065	1910	3192
Command & service module separation ^b										
Before	87 057.3	399.3	5.6	0.8	51 517	428 065	433 819	9058	1909	3194
After (command module/ lunar module)	37 409.7	251.5	2.2	-0.3	24 046	92 410	93 809	2362	-969	9
Command module/lunar module separation ^a										
Before ^b	37 014.6	252.9	1.9	-0.6	23 926	93 993	95 514	2188	-963	-35
After (command module)	12 367.6	1039.9	0.3	6.1	5 815	5 258	4 626	31	-409	20
Entry	12 361.4	1039.9	0.3	6.0	5 812	5 254	4 635	31	-407	21
Drogue deployment	11 869.4	1038.7	0.3	6.0	5 727	5 002	4 405	33	-382	24
Main parachute deployment	11 579.8	1035.6	0.5	5.3	5 590	4 812	4 346	27	-319	41
Landing	11 132.9	1036.6	0.5	5.2	5 526	4 531	4 046	25	-328	42

^aLunar module was docked to the command module from initial docking until just prior to entry.

^bMass properties are referenced to the coordinate system of the lunar module, which provided spacecraft dynamic control during these phases.

APPENDIX B - SPACECRAFT HISTORIES

The history of command and service module (CSM 109) operations at the manufacturer's facility, Downey, California, is shown in figure B-1, and the operations at Kennedy Space Center, Florida, in figure B-2.

The history of the lunar module (LM-7) at the manufacturer's facility, Bethpage, New York, is shown in figure B-3, and the operations at Kennedy Space Center, Florida, in figure B-4.

NASA-S-70-5866

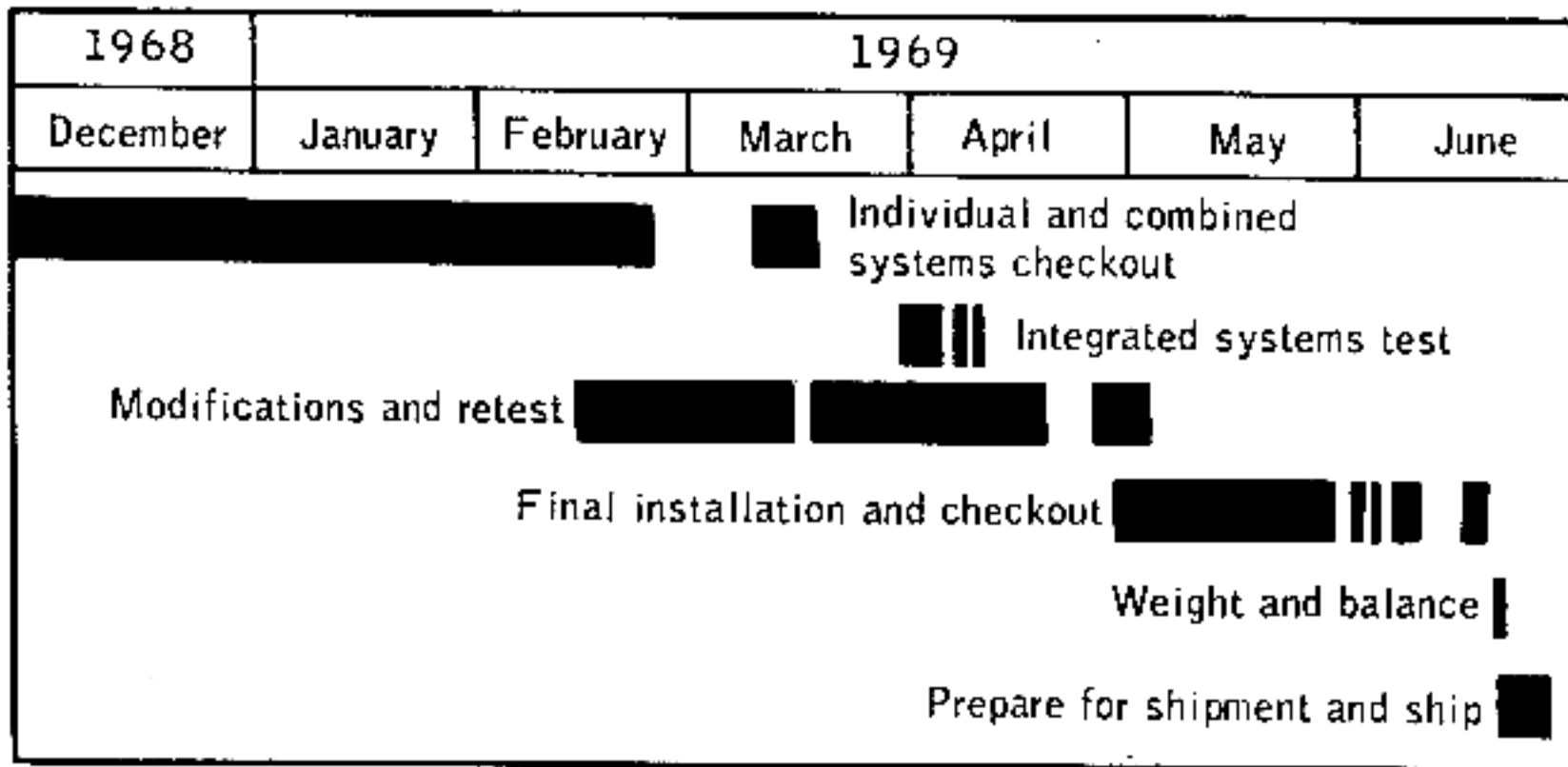

Figure B-1.- Checkout flow for command and service modules at contractor's facility.

NASA-S-70-5867

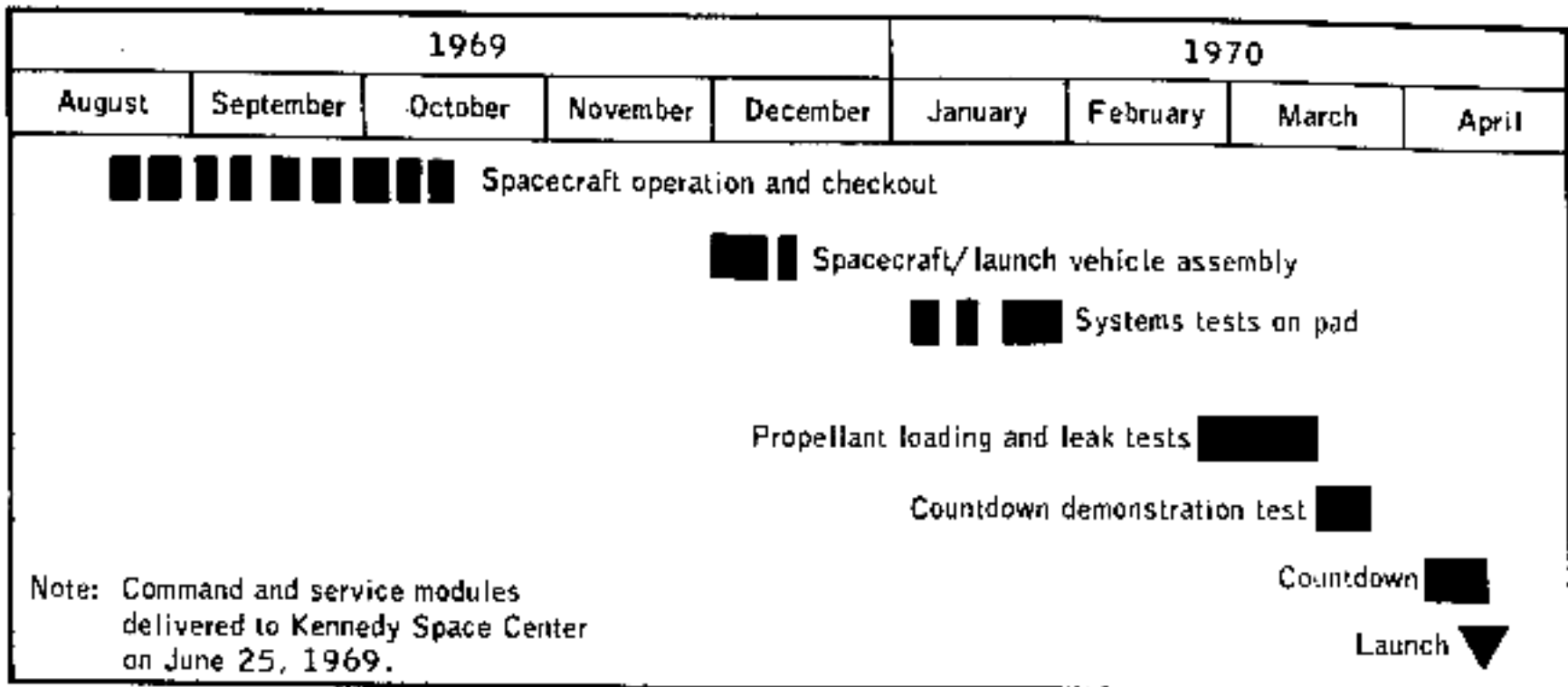

Figure B-2.- Command and service module checkout history at Kennedy Space Center.

NASA-S-70-5868

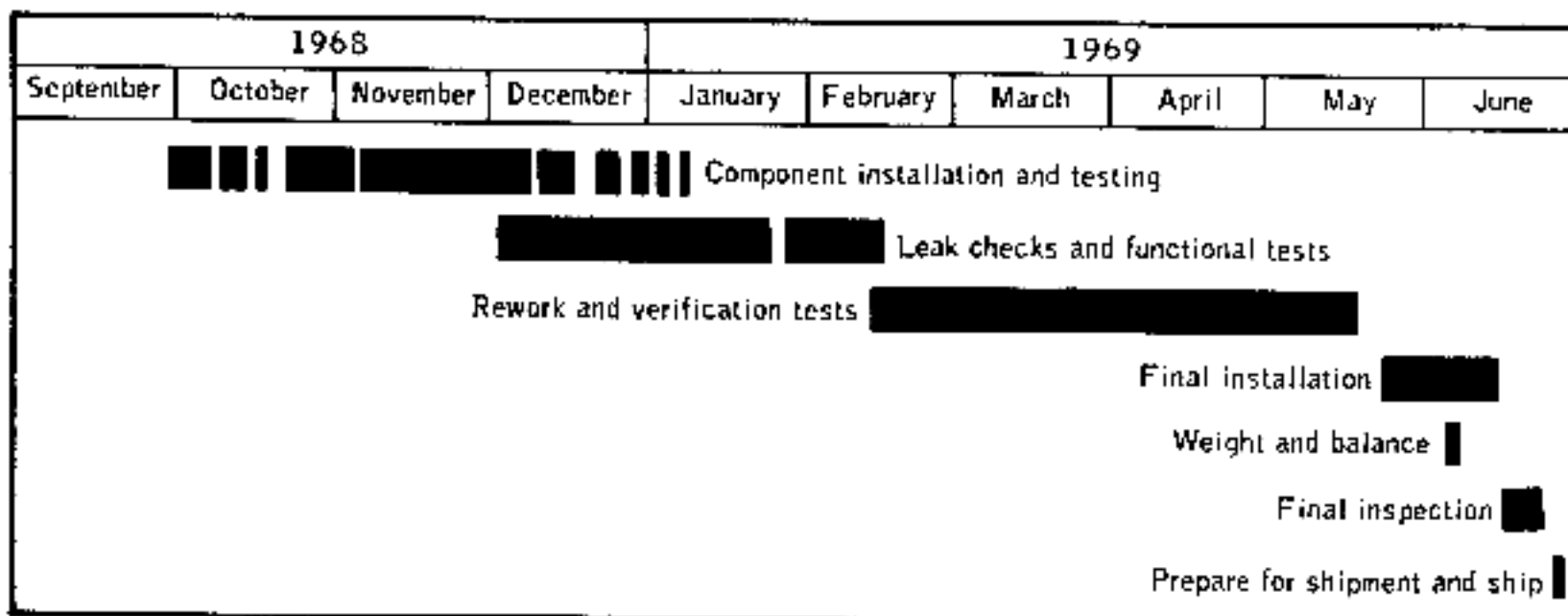

Figure B-3.- Checkout flow for lunar module at contractor's facility.

NASA-S-70-5869

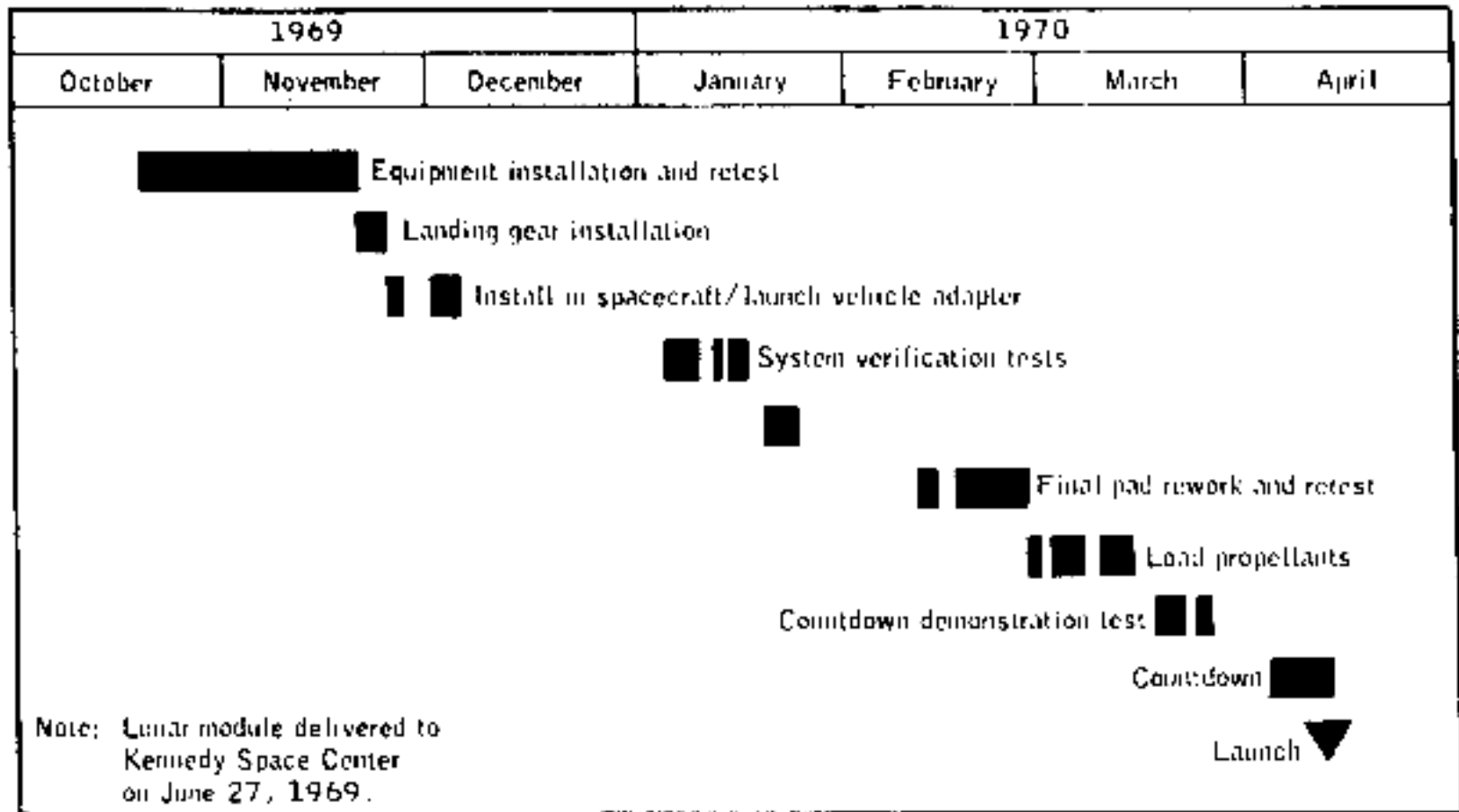

Figure B-4.- Lunar module checkout history at Kennedy Space Center.

APPENDIX C - POSTFLIGHT TESTING

The command module arrived at the contractor's facility in Downey, California, on April 27, 1970, after reaction control system deactivation and pyrotechnic safing in Hawaii. Postflight testing and inspection of the command module for evaluation of the inflight performance and investigation of the flight irregularities were conducted at the contractor's and vendors' facilities in accordance with approved Apollo Spacecraft Hardware Utilization Requests (ASHUR's). The tests performed as a result of inflight problems are described in table C-I and discussed in the appropriate systems performance sections of this report. Tests being conducted for other purposes in accordance with other ASHUR's and the basic contract are not included.

TABLE C-I.- POSTFLIGHT TESTING SUMMARY

ASHUR	Purpose	Tests performed	Results
Environmental Control			
109007	To determine contaminants present or damage incurred in 900 psi system	Analyze the oxygen filters upstream of restrictors and check valves for contaminants. Perform acceptance test of oxygen in air regulator	
109008	To determine contaminants present in residual oxygen in surge tank and repressurization package	Withdraw sample and analyze for contaminants	No significant difference from the analysis performed at loading
109016	To investigate the failure of the postlanding ventilation valve to cycle open	Determine position of inlet valve mechanical safety pin. Attempt to operate valve, then remove for failure analysis	Not complete
109020	To determine the cause of failure of the suit pressure transducer	Perform calibration check, disassembly, and failure analysis	Not complete
109021	To determine the cause of failure of the potable water transducer	Remove, disassemble, and perform failure analysis	Not complete
Guidance and Navigation			
109015	To investigate the cause for optics coupling display unit indications of optics movement during the zero optics mode	Performance check of zero optics mode operation	Unable to perform tests on optical unit due to salt water contamination
109018	To investigate the failure of the 0.0% indication during entry	Verify the 0.0% entry monitor system circuit, check the connectors, lamp, and wiring	Not complete

APPENDIX D - DATA AVAILABILITY

Tables D-I and D-II are summaries of the data made available for systems performance analyses and anomaly investigations. Table D-I lists the data from the command and service modules, and table D-II, for the lunar module. For additional information regarding data availability, the status listing of all mission data in the Central Metric Data File, building 12, MSC, should be consulted.

TABLE D-I.- COMMAND AND SERVICE MODULE DATA AVAILABILITY

Time, hr:min		Range station	Bandpass plots or tabs	Hilevels	Computers words	O'graph records	Brush records	Special plots or tabs	Special programs
From	To								
00:00	00:12	MILA	X	X	X	X	X	X	X
00:02	00:14	BCA	X			X	X		
00:04	04:44	MSPN	X		X				
00:07	00:18	VAN	X	X		X	X		
00:14	00:28	CYI	X	X		X	X		
01:31	01:33	GDS	X	X		X	X		
01:33	01:45	MCLA	X	X		X	X		
01:48	01:59	CYI	X	X		X	X		
02:25	02:34	CHO	X	X		X	X		
02:34	02:45	HAW				X			
02:43	02:50	HAW	X	X		X	X		
02:49	13:59	GDS	X	X		X	X	X	X
04:44	08:35	MSPN	X	X	X				
08:35	12:49	MSPN	X	X	X				
12:49	16:44	MSPN	X	X	X				
13:18	17:12	HSK	X	X		X	X		
16:44	20:37	MSPN	X	X	X				
17:15	25:00	MAD	X	X		X	X	X	
20:37	27:01	MSPN	X	X	X				
24:53	37:42	GDS	X	X		X	X	X	
27:01	40:55	MSPN	X	X	X				
37:33	42:47	HSK	X	X		X	X	X	
40:55	44:38	MSPN	X	X	X				
44:38	52:37	MSPN	X	X	X				
50:21	58:39	GDS	X	X	X	X	X	X	X
52:37	58:39	MSPN	X	X	X				
101:53	101:58	GDS	X	X					
123:03	123:12	GDS	X	X					
140:12	141:08	HSK	X	X					
140:15	142:39	MSPN	X	X	X				
140:48	141:50	GWA	X	X					
141:26	142:14	CRC			X				
142:12	142:38	CHO	X	X	X				
142:36	142:44	ARIA	X	X	X				
142:40	142:59	ARIA	X	X	X				

TABLE D-II.- LUNAR MODULE DATA AVAILABILITY - Concluded

Time, hr:min		Range station	Sandpass plots or tabs	Bilevels	Computer words	O'graph records	Brush records	Special plots or tabs	Special programs
From	To								
57:57	58:05	GDS	X	X					
57:57	60:36	MSPY	X	X	X			X	
58:12	59:12	GDS	X	X					
60:36	64:50	MSPY	X	X	X		X		
61:10	62:13	GDS	X	X	X				
64:52	68:26	MSPY	X	X		X	X	X	X
65:07	66:07	HSK		X					
68:26	72:24	MSPY	X	X					
72:32	77:03	MSPY	X	X					
77:03	80:29	MSPY	X	X	X				
78:47	79:47	GDS	X	X	X				
80:29	96:29	MSPY	X	X		X	X	X	X
93:30	93:40	MAD		X					
94:56	95:05	MAD		X			X		
96:29	100:33	MSPY	X	X					
97:11	97:18	MAD	X						
97:12	97:18	ACN						X	
99:24	99:57	GDS	X	X		X			
99:50	100:24	GDS	X	X			X		
100:33	104:57	MSPY	X	X					
101:00	101:07	GDS					X		
104:19	105:19	GDS	X	X	X				
104:57	106:36	MSPY	X	X	X				
105:15	105:53	GDS	X	X	X				
108:36	112:35	MSPY	X	X		X		X	
108:52	109:08	GDS							
109:12	109:25	GDS	X	X	X			X	
112:35	120:25	MSPY	X	X					
117:33	120:34	MAD	X	X					
102:26	136:52	MSPY	X	X					
133:46	134:39	GDS			X				
134:20	135:20	HSK			X				
136:30	136:50	HSK			X				
136:52	138:34	MSPY	X	X	X				
137:14	138:14	HSK	X	X	X				
138:34	142:38	MSPY	X	X	X		X		X
141:25	141:35	CPC					X		
141:28	141:32	GWM	X	X	X			X	X

APPENDIX E - MISSION REPORT SUPPLEMENTS

Table E-I contains a listing of all supplemental reports that are or will be published for the Apollo 7 through Apollo 13 mission reports. Also indicated in the table is the present status of each report not published or the publication date for those which have been completed.

TABLE E-1.- MISSION REPORT SUPPLEMENTS

Supplement number	Title	Publication date/status
Apollo 7		
1	Trajectory Reconstruction and Analysis	May 1969
2	Communication System Performance	June 1969
3	Guidance, Navigation, and Control System Performance Analysis	November 1969
4	Reaction Control System Performance	August 1969
5	Cancelled	
6	Entry Postflight Analysis	December 1969
Apollo 8		
1	Trajectory Reconstruction and Analysis	December 1969
2	Guidance, Navigation, and Control System Performance Analysis	November 1969
3	Performance of Command and Service Module Reaction Control System	March 1970
4	Service Propulsion System Final Flight Evaluation	September 1970
6	Analysis of Apollo 8 Photography and Visual Observations	December 1969
7	Entry Postflight Analysis	December 1969
Apollo 9		
1	Trajectory Reconstruction and Analysis	November 1969
2	Command and Service Module Guidance, Navigation, and Control System Performance	November 1969
3	Lunar Module Abort Guidance System Performance Analysis	November 1969
4	Performance of Command and Service Module Reaction Control System	April 1970
5	Service Propulsion System Final Flight Evaluation	December 1969
6	Performance of Lunar Module Reaction Control System	Final review
7	Ascent Propulsion System Final Flight Evaluation	December 1969
8	Descent Propulsion System Final Flight Evaluation	September 1970
9	Cancelled	
10	Stroking Test Analysis	December 1969
11	Communications System Performance	December 1969
12	Entry Postflight Analysis	December 1969

TABLE E-I.- MISSION REPORT SUPPLEMENTS - Continued

Supplement number	Title	Publication date/status
Apollo 10		
1	Trajectory Reconstruction and Analysis	March 1970
2	Guidance, Navigation, and Control System Performance Analysis	December 1969
3	Performance of Command and Service Module Reaction Control System	Final review
4	Service Propulsion System Final Flight Evaluation	September 1970
5	Performance of Lunar Module Reaction Control System	Final review
6	Ascent Propulsion System Final Flight Evaluation	January 1970
7	Descent Propulsion System Final Flight Evaluation	January 1970
8	Cancelled	
9	Analysis of Apollo 10 Photography and Visual Observations	In publication
10	Entry Postflight Analysis	December 1969
11	Communications System Performance	December 1969
Apollo 11		
1	Trajectory Reconstruction and Analysis	May 1970
2	Guidance, Navigation, and Control System Performance Analysis	September 1970
3	Performance of Command and Service Module Reaction Control System	Review
4	Service Propulsion System Final Flight Evaluation	Review
5	Performance of Lunar Module Reaction Control System	Review
6	Ascent Propulsion System Final Flight Evaluation	September 1970
7	Descent Propulsion System Final Flight Evaluation	September 1970
8	Cancelled	
9	Apollo 11 Preliminary Science Report	December 1969
10	Communications System Performance	January 1970
11	Entry Postflight Analysis	April 1970

TABLE E-I.- MISSION REPORT SUPPLEMENTS - Concluded

Supplement number	Title	Publication date/status
Apollo 12		
1	Trajectory Reconstruction and Analysis	September 1970
2	Guidance, Navigation, and Control System Performance Analysis	September 1970
3	Service Propulsion System Final Flight Evaluation	Preparation
4	Ascent Propulsion System Final Flight Evaluation	Preparation
5	Descent Propulsion System Final Flight Evaluation	Preparation
6	Apollo 12 Preliminary Science Report	July 1970
7	Landing Site Selection Processes	Final review
Apollo 13		
1	Guidance, Navigation, and Control System Performance Analysis	Review
2	Descent Propulsion System Final Flight Evaluation	Preparation
3	Entry Postflight Analysis	Cancelled

REFERENCES

1. Manned Spacecraft Center: Apollo 13 Cryogenic Oxygen Tank 2 Anomaly Report. MSC-02545. June 1970.
2. Marshall Space Flight Center: Saturn V Launch Vehicle Flight Evaluation Report AS-508 Apollo 13 Mission. MPR-SAT-FE-70-2. June 1970.
3. Marshall Space Flight Center, Kennedy Space Center, Manned Spacecraft Center: Analysis of Apollo 12 Lightning Incident, MSC-01540. February 1970.
4. ICSU/IUGG Committee on Atmospheric Sciences: Report of the Study Conference on the Global Atmospheric Research Program, 1967.
5. Bulletin of the American Meteorological Society, Vol. 50, No. 7: Cloud Height Contouring from Apollo 6 Photography, by V. S. Whitehead, I. D. Browne, and J. G. Garcia. 1969.
6. Defense Supply Agency, Washington, D. C.: Military Standardization Handbook Optical Design, MIL HDBK-141. 1962.
7. NASA Headquarters: Apollo Flight Mission Assignments. OMSF M-D MA 500-11 (SE 010-000-1). October 1969.
8. Manned Spacecraft Center: Mission Requirement, H-2 Type Mission (Lunar Landing). SPD9-R-053. November 10, 1969.

APOLLO SPACECRAFT FLIGHT HISTORY

(Continued from inside front cover)

<u>Mission</u>	<u>Spacecraft</u>	<u>Description</u>	<u>Launch date</u>	<u>Launch site</u>
Apollo 4	SC-017 LTA-10R	Supercircular entry at lunar return velocity	Nov. 9, 1967	Kennedy Space Center, Fla.
Apollo 5	LM-1	First lunar module flight	Jan. 22, 1968	Cape Kennedy, Fla.
Apollo 6	SC-020 LTA-2R	Verification of closed-loop emergency detection system	April 4, 1968	Kennedy Space Center, Fla.
Apollo 7	CSM 101	First manned flight; earth-orbital	Oct. 11, 1968	Cape Kennedy, Fla.
Apollo 8	CSM 103	First manned lunar orbital flight; first manned Saturn V launch	Dec. 21, 1968	Kennedy Space
Apollo 9	CSM 104 LM-3	First manned lunar module flight; earth orbit rendezvous; EVA	Mar. 3, 1969	Kennedy Space Center, Fla.
Apollo 10	CSM 106 LM-4	First lunar orbit rendezvous; low pass over lunar surface	May 18, 1969	Kennedy Space Center, Fla.
Apollo 11	CSM 107 LM-5	First lunar landing	July 16, 1969	Kennedy Space Center, Fla.
Apollo 12	CSM 108 LM-6	Second lunar landing	Nov. 14, 1969	Kennedy Space Center, Fla.
Apollo 13	CSM 109 LM-7	Aborted during trans-lunar flight because of cryogenic oxygen loss	April 11, 1970	Kennedy Space Center, Fla.