

## CHAPTER 2

# MAINTENANCE

*This chapter addresses the proper care of the machine gun to ensure its overall effectiveness and efficient functioning. The information includes the gunner's knowledge in disassembly and assembly, inspection, and maintenance procedures of the gun, its mount, the T&E, and its ammunition.*

### 2-1. SAFETY

The paramount consideration while training with the machine gun is safety. It is imperative that the weapon be cleared properly before disassembly and inspection. (See Figure 2-1 for step-by-step procedures.)

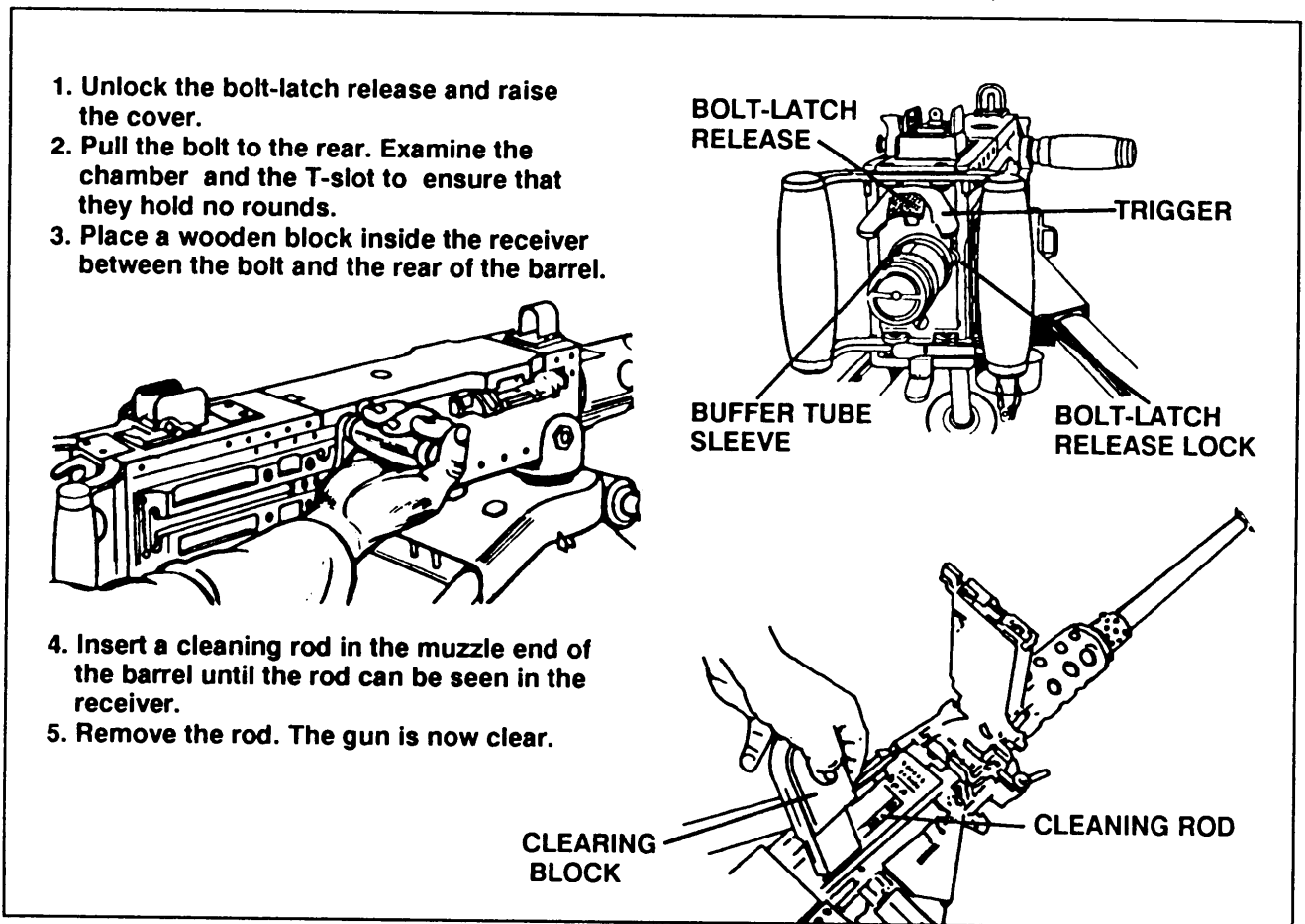

Figure 2-1. Clearing the weapon.

## 2-2. GENERAL DISASSEMBLY

The crew operating the MG must be fully familiar with its general disassembly, which consists of removing the major groups and assemblies for inspection and cleaning. The eight major groups that must be disassembled in the following order are barrel group, backplate group, driving spring rod assembly, bolt group, barrel extension group, barrel buffer body group, barrel buffer assembly, and receiver group (Figure 2-2).

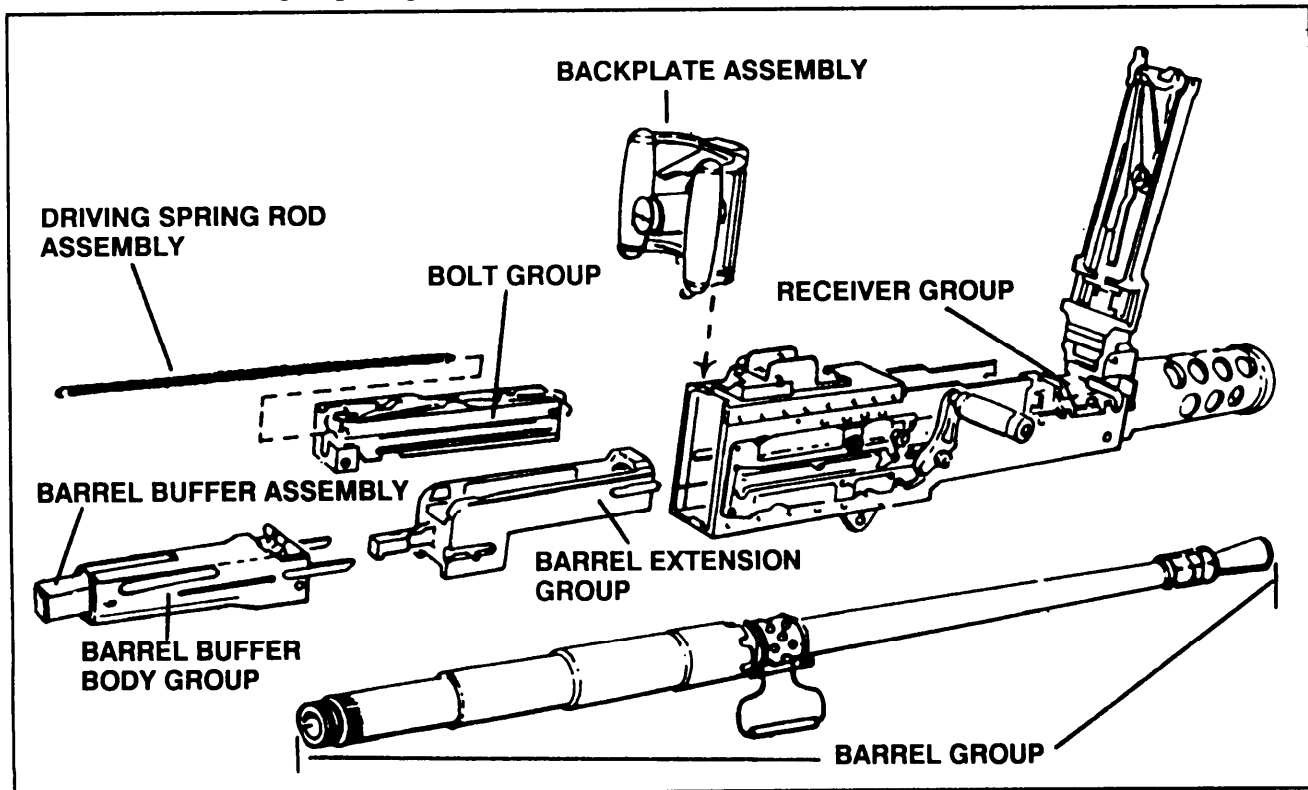

Figure 2-2. Major groups.

a. **Barrel Group.** Turn the cover latch and raise the cover group (Figure 2-3). Grasp the retracting slide handle with the right hand, palm up, and pull the recoiling parts to the rear until the lug on the barrel locking spring aligns with the 3/8-inch hole in the right sideplate of the receiver (just below the feedway exit). The barrel can be turned only when the lug is aligned with the 3/8-inch hole. Place the smallest loop of a caliber .50 link, or suitable spacer, between the trunnion block and the barrel extension (Figure 2-4). This holds the barrel locking spring lug aligned with the 3/8-inch hole in the right sideplate. Unscrew the barrel from the receiver (Figure 2-5, page 2-4). Be careful not to damage the

threads or barrel locking notches when setting the barrel down. Pull back slightly on the retracting slide handle and remove the link or spacer from the receiver.

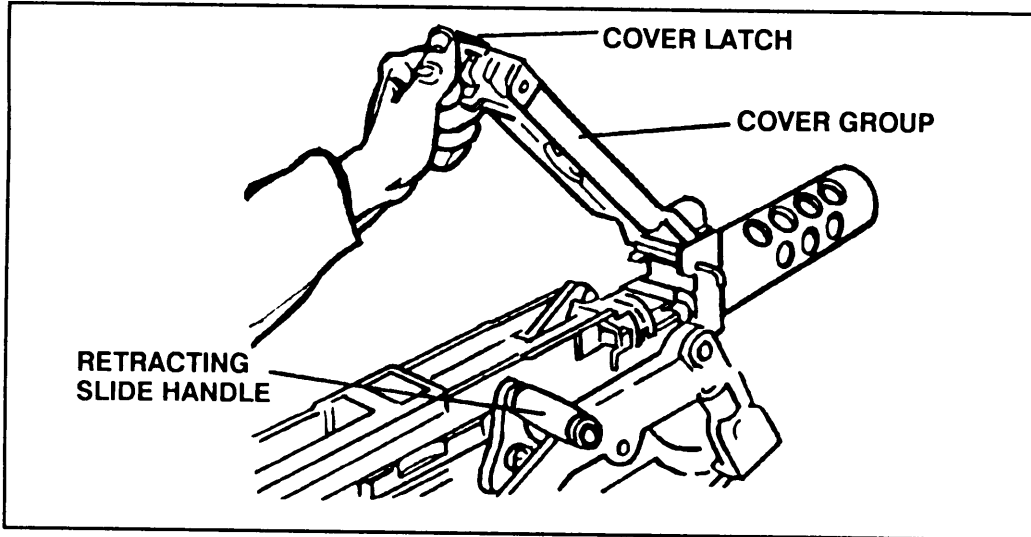

Figure 2-3. Raising the cover.

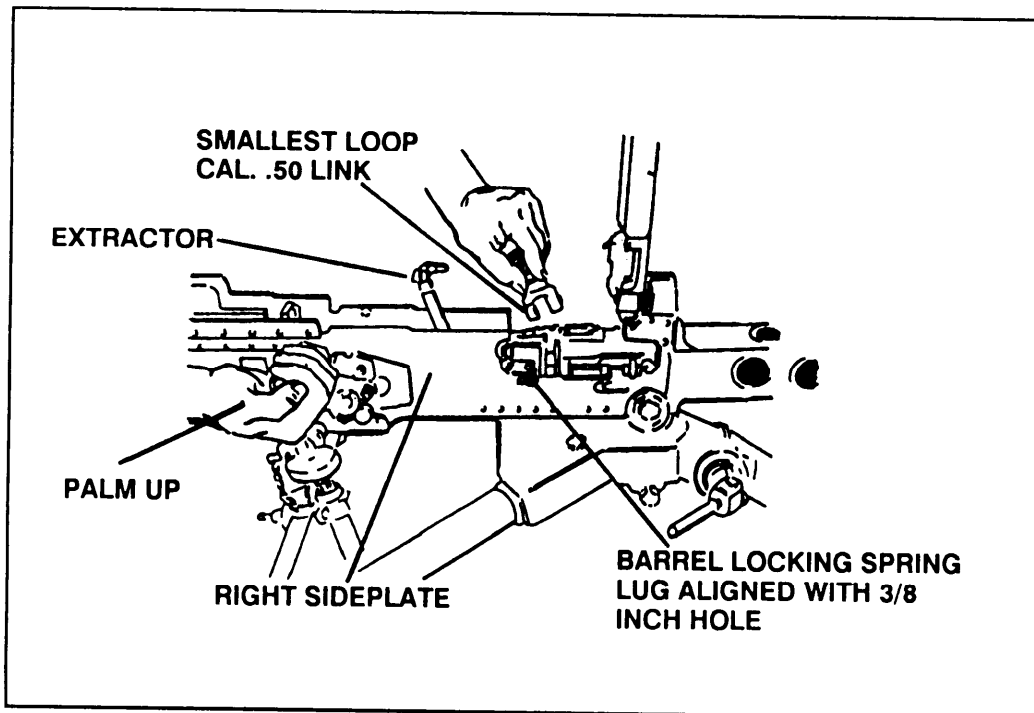

Figure 2-4. Aligning the lug on the barrel locking spring with the 3/8-inch hole in the right sideplate.

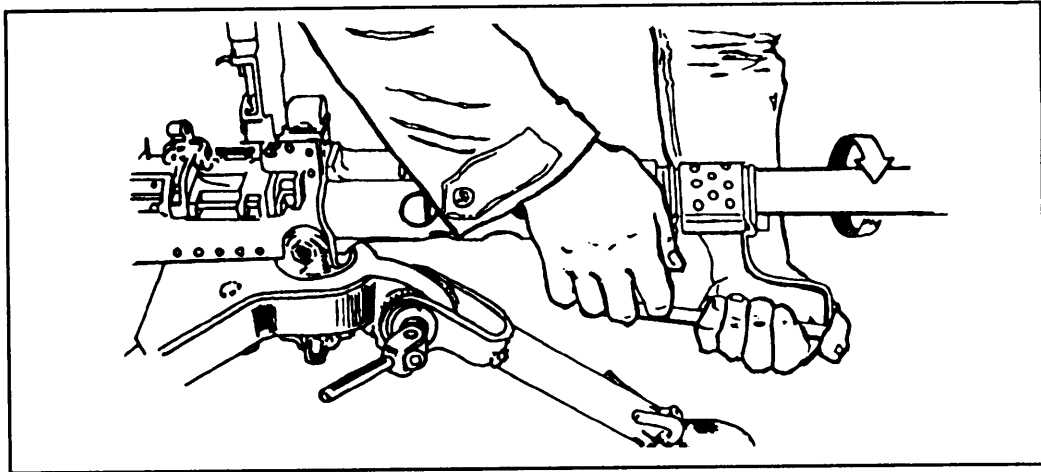

Figure 2-5. Removing the barrel.

b. **Backplate Group.** Ensure that the bolt latch release is up, free of the bolt latch release lock. If it is not, push down on the bolt latch release and turn the buffer tube sleeve to the right to free it (Figure 2-6). The bolt must be forward before the backplate is removed. If the bolt is to the rear, push down on the bolt latch release, place palm up on the retracting slide handle, and ease the bolt forward. The backplate latch lock and latch are below the buffer tube. Pull out on the lock and up on the latch; remove the backplate by lifting it straight up (Figure 2-7).

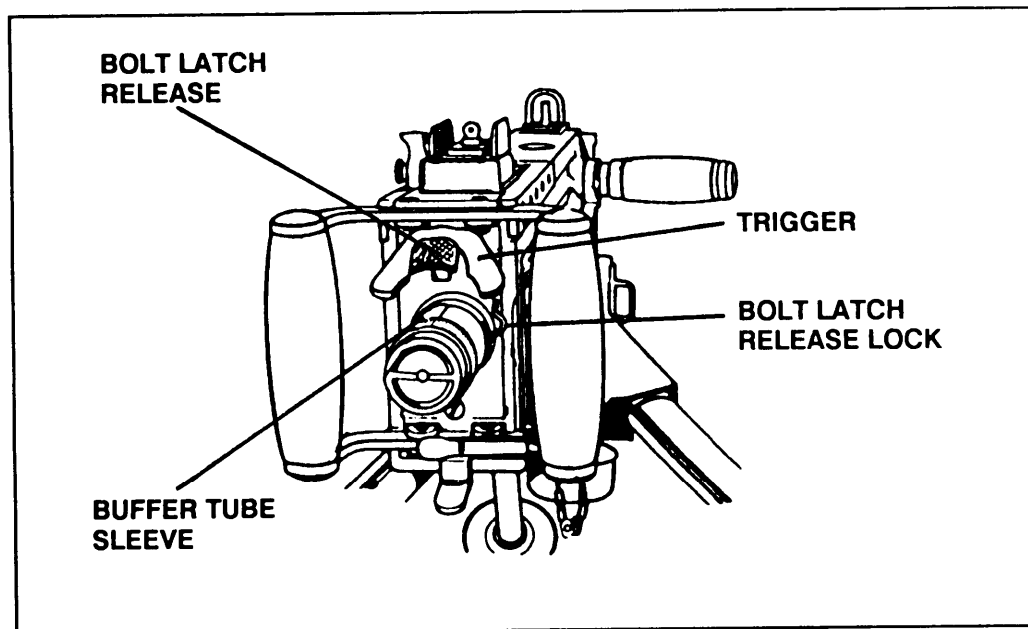
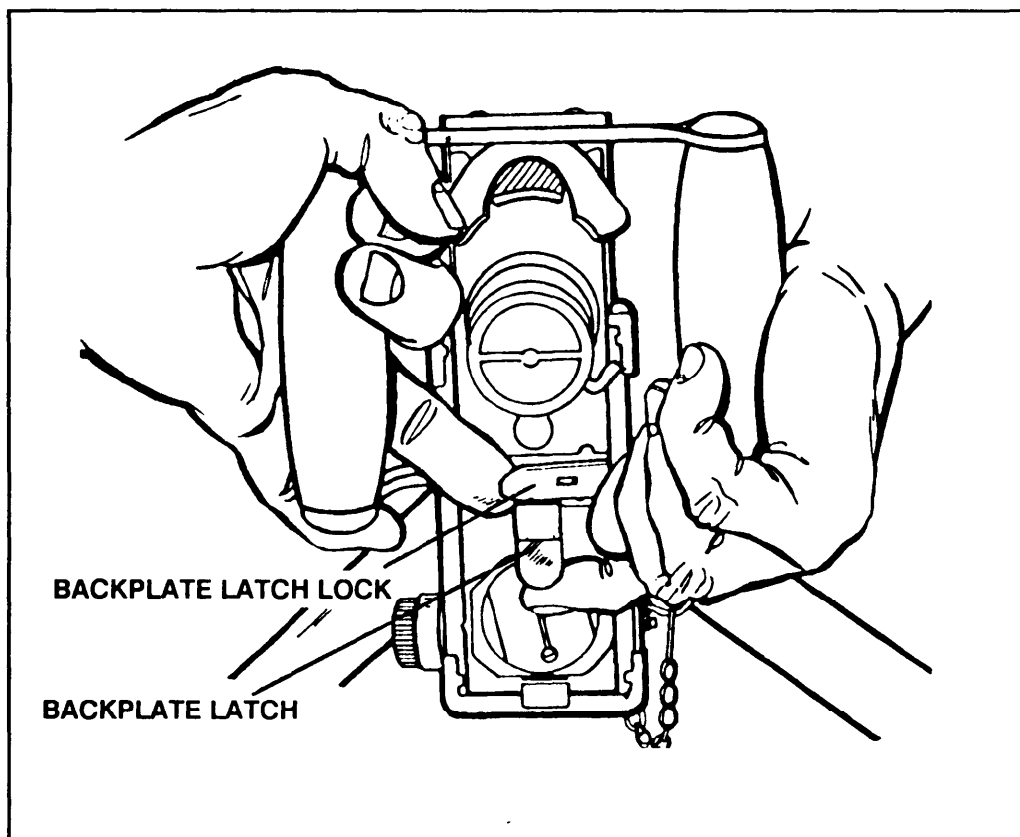

Figure 2-6. Releasing the bolt latch.

**CAUTION**

Care must be taken to prevent the bolt from slamming forward with the barrel removed.

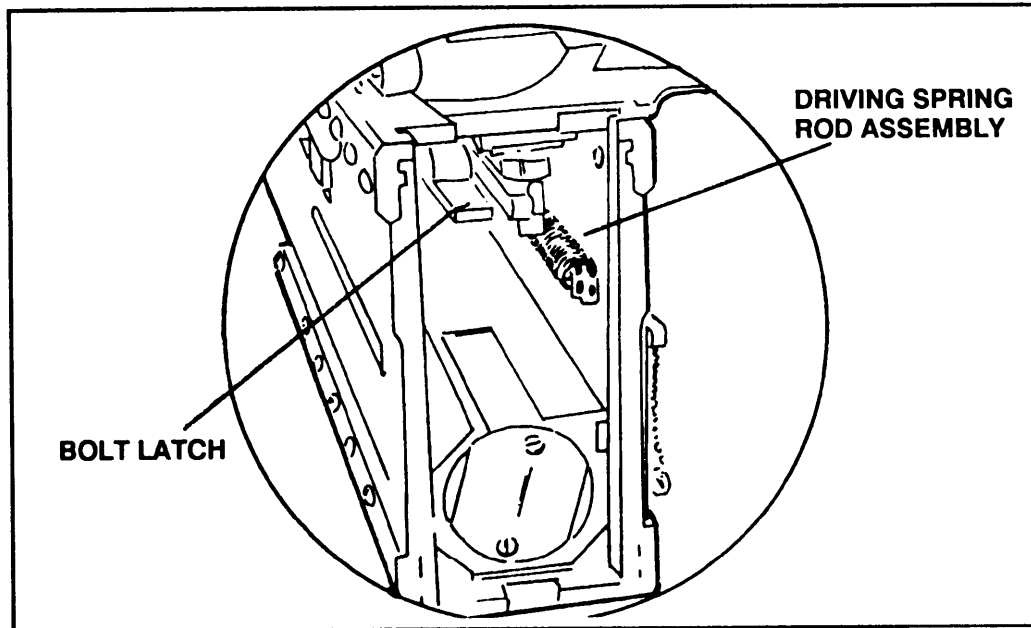

**Figure 2-7. Removing the backplate.**

c. **Driving Spring Rod Assembly.** The inner and outer driving springs and driving spring rod are located inside the receiver next to the right sideplate (Figure 2-8, page 2-6). Push in on the head of the driving spring rod and push to the left to remove the driving spring rod retaining pin from its seat in the right sideplate. Pull the driving spring assembly to the rear and out of the receiver.

**WARNING**

Never attempt to cock the gun while the backplate is off and the driving spring assembly is in place. If the backplate is off and the driving spring assembly is compressed, the retaining pin on the driving spring rod can slip from its seat in the sideplate and could cause serious injury to anyone behind the gun.



**Figure 2-8. Removing the driving spring rod assembly.**

d. **Bolt Stud.** Grasp the retracting slide handle and give it a quick jerk, freeing the bolt from the barrel extension. Align the collar of the bolt stud with the clearance hole in the bolt slot on the right sideplate, and remove the bolt stud (Figure 2-9). If the bolt is accidentally moved all the way to the rear, the bolt latch will engage in the bolt latch notches in the top of the bolt. If this occurs, raise the bolt latch (left of the trigger lever) and push the bolt forward to align the bolt stud with the clearance hole (Figure 2-10).

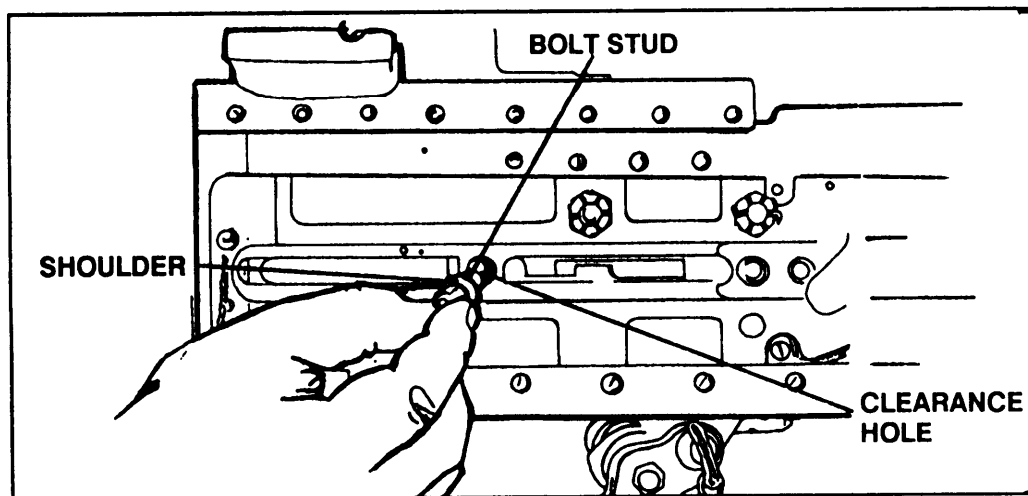

**Figure 2-9. Removing the bolt stud.**

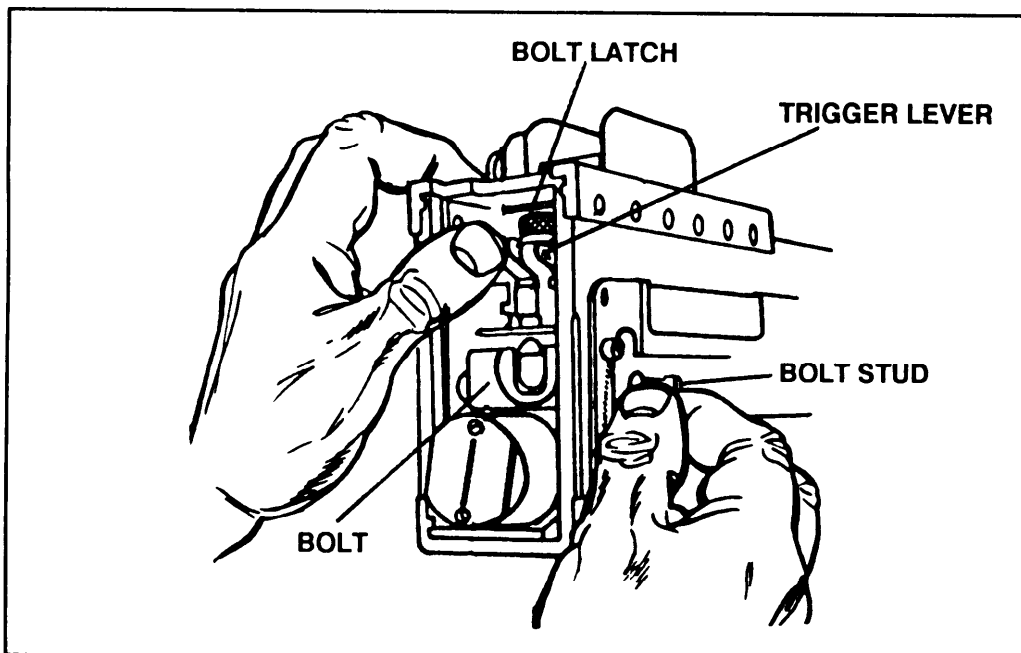

Figure 2-10. Freeing the bolt.

e. **Bolt Group.** After freeing the bolt, slide it to the rear and out of receiver (Figure 2-11). Place the bolt down on its right side (with the extractor arm up), so that the extractor will not fall from the bolt.

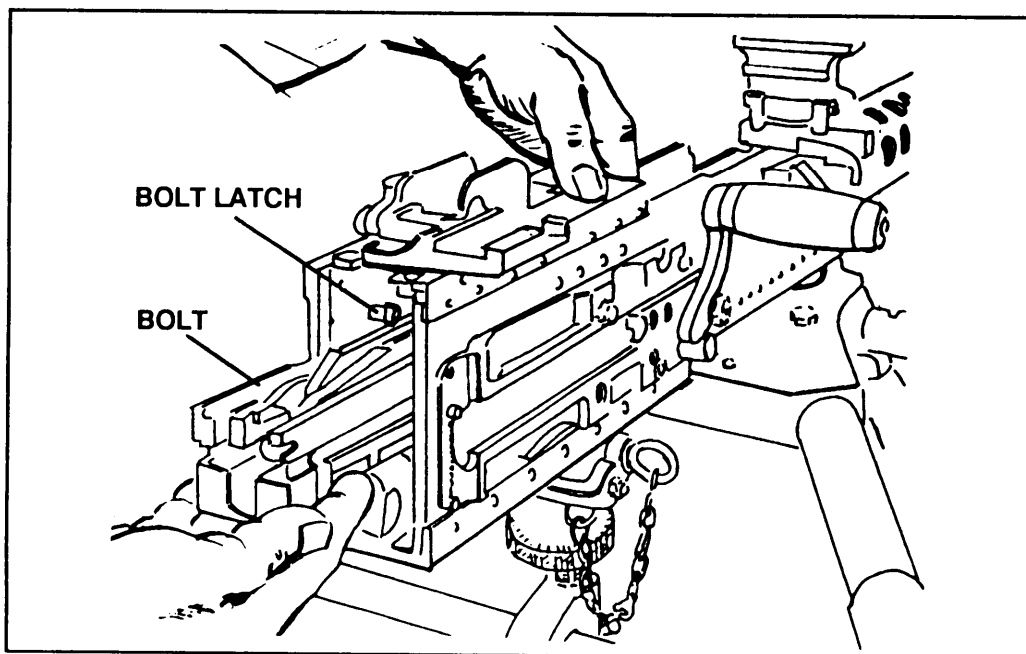

Figure 2-11. Removing the bolt from the receiver.

f. **Barrel Buffer Body Group and Barrel Extension Group.** Insert the drift of a combination tool, or other pointed instrument, through the hole in the lower rear corner of the right sideplate. Push in on the barrel buffer body lock. At the same time, place one hand in the receiver and push the barrel extension group and barrel buffer group to the rear (Figure 2-12). Remove the barrel buffer group and barrel extension group from the receiver. Separate the two groups by pushing forward on the tips of the accelerator (Figure 2-13).

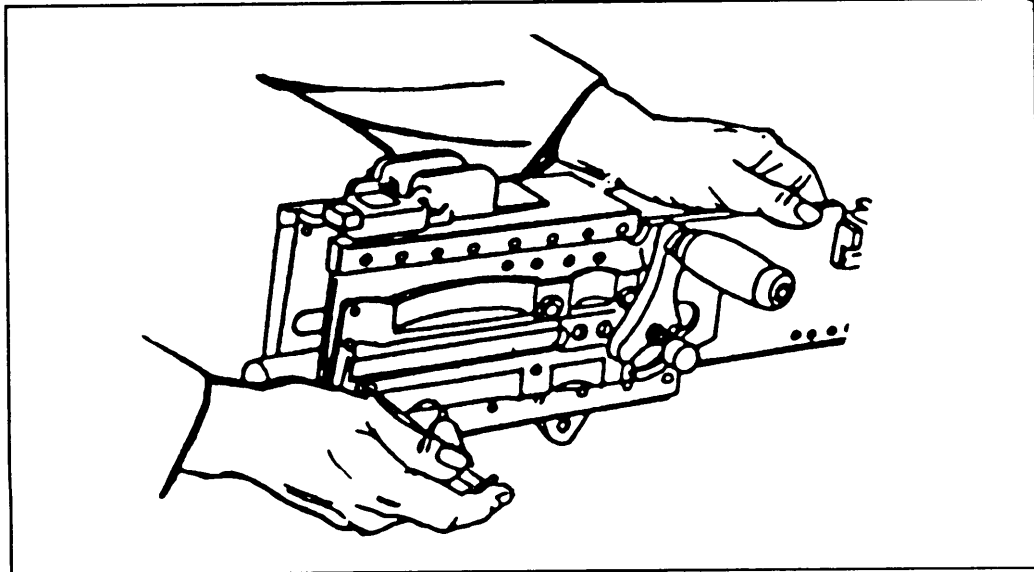

Figure 2-12. Removing barrel buffer group and barrel extension group.

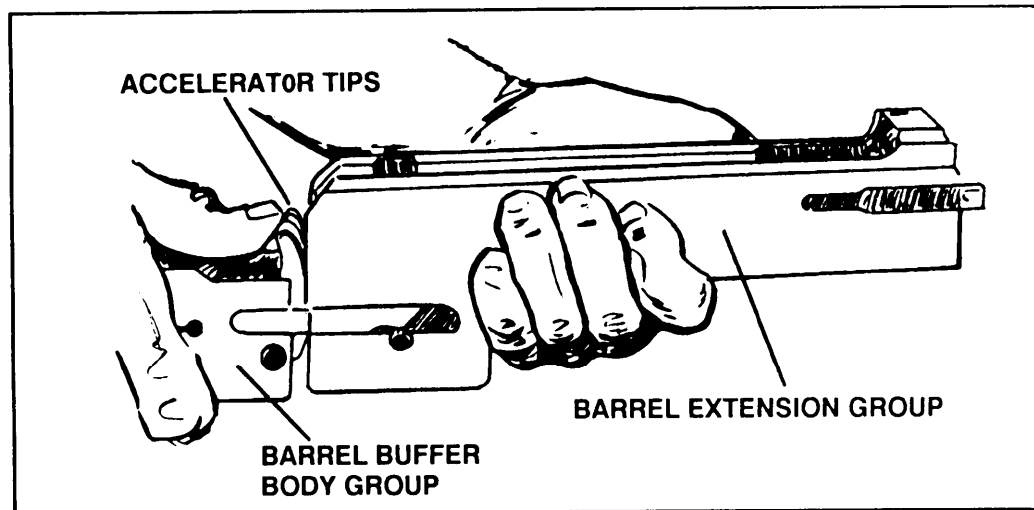
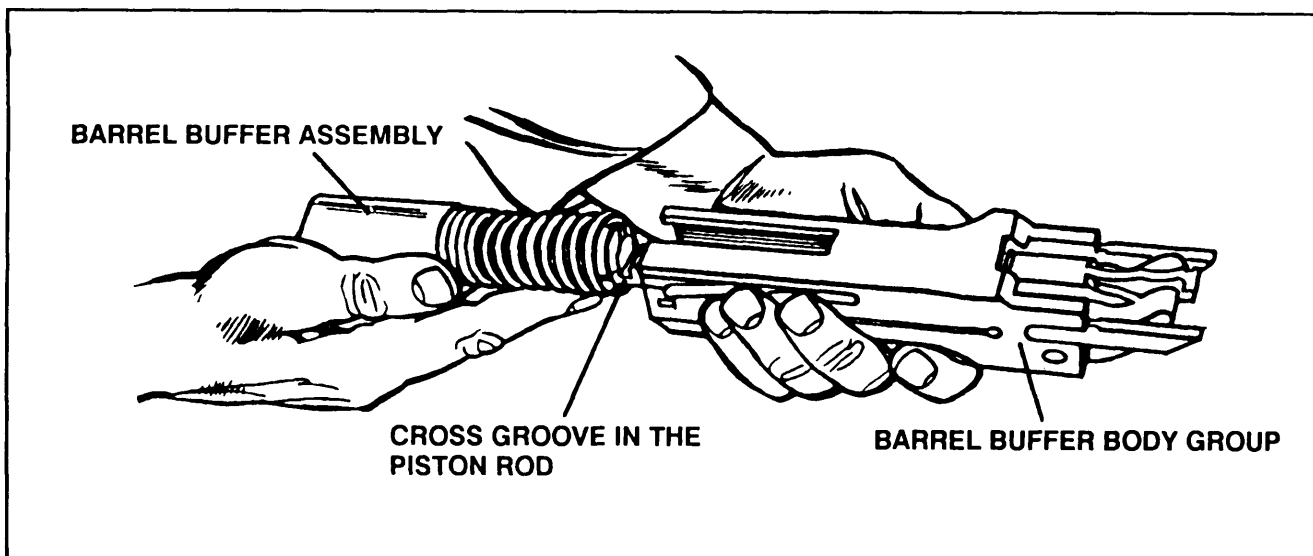

Figure 2-13. Separating the groups.



g. **Barrel Buffer Assembly.** Pull the barrel buffer assembly from the rear of the barrel buffer body group. The barrel buffer assembly will not be disassembled (Figure 2-14). This completes general disassembly.



**Figure 2-14. Separating the barrel buffer assembly from the barrel buffer body group.**

### **2-3. CLEANING, INSPECTION, AND LUBRICATION**

To ensure proper care of the MG, it is necessary to have a system of maintenance or an SOP for the frequency of cleaning. Each gun should be cleaned as soon after firing as possible and each time it is exposed to field conditions. Under combat conditions, the gun should be cleaned and oiled daily. Under extreme climatic and combat conditions, it may be necessary to clean and lubricate more frequently. Under ideal conditions, where the gun is not used, and is stored in a clean, dry place, it may only be necessary to inspect, clean, and lubricate every 5 days. The gun should be disassembled, cleaned, and oiled in a clean, dry location. If possible, keep the gun covered with a gun cover, canvas, tarpaulin, or poncho when not in use.

a. **Routine Care and Cleaning.** Before firing (when the situation permits), take the following steps to ensure efficient functioning of the machine gun:

- Disassemble the gun into its major groups or assemblies.
- Clean the bore and chamber, and lightly oil them.
- Clean all metal parts thoroughly with CLP. See paragraph 2-3f for lubrication procedures.

b. **Care and Cleaning Under Unusual Conditions.** Extreme cold, hot, dry, and tropical climates affect the gun and its functioning. Care should be taken under these climatic conditions to ensure that the gun is cleaned daily with the prescribed lubricants and protected from the elements by some sort of cover if possible. Further information on care and cleaning of the gun under unusual climatic conditions can be found in TM 9-1005-213-10.

c. **Care and Cleaning of M3 Mount and Accessories.** The mount and accessories, such as the ammunition chest and spare parts, should also be kept clean and lubricated. Painted surfaces should be spot painted when necessary. Moving surfaces should be inspected and oiled with the prescribed lubricant. All external surfaces of the mount should be kept clean and lightly oiled. Be particularly careful that the pintle bushing is clean and lightly oiled, and that the pintle lock release cam is well-lubricated and free from grit. The sleeve lock indexing levers and telescopic legs should be clean and lubricated enough for ease in use. The mount should be cleaned and oiled with the same regularity and in the same manner as the gun.

d. **Maintenance and Inspection.** Units must establish guidelines and conduct regular maintenance and inspection to keep the machine gun and its mounts in operational conditions.

(1) *Gun maintenance.* The importance of a thorough knowledge of care, cleaning, and maintenance of the machine gun cannot be overemphasized because these actions determine whether or not the gun will function properly when needed. The bore and chamber must be properly maintained to preserve accuracy. Because of the close fit of working surfaces and the high speed at which the gun operates, the receiver and moving parts must be kept clean, correctly lubricated, and free from burrs, rust, dirt, or grease to ensure proper, efficient functioning.

(2) *Mount maintenance.* The care, cleaning, lubrication, and adjustment of the mounts used with the gun are no less important. The functioning of the gun and mount together determine overall effectiveness. All accessories and equipment used with the gun and mount, including ammunition, must also be properly maintained.

(3) *Inspection.* When inspected, the machine gun should be completely disassembled. Inspecting personnel should look for dirt, cracks, burrs, and rust.

e. **Inspection Checklist.** Table 2-1 is an inspection checklist to be used as a guide for crewmembers or inspecting personnel to ensure that the gun and equipment are properly maintained.

UNIT	INSPECTION
1. GUN.	
a. Barrel.	Inspect the bore and chamber for rust. See that they are clean and lightly oiled.
b. Moving parts.	See that they are clean and lightly oiled. Operate the retracting slide handle and bolt latch release several times to see that the parts function without excessive friction.
c. Headspace and timing.	Check with the gauges to ensure that headspace and timing are correct.
d. Rear sight and windage knob.	Ensure that the sight is in good condition, clean, free of grease or dirt, and lightly oiled. Elevation should be set at 1,000, windage zero, and the sight should be down.
2. MOUNT (M3, MK64, M36, or M4).	See that it is clean, lightly lubricated, and that all clamps are securely tightened. It should function properly and be complete.
3. SPARE PARTS AND TOOLS.	Inspect to see that they are clean and lightly oiled. See that spare parts kits are complete and in good condition. Replacement parts should be requisitioned and newly drawn parts examined.
4. T&E.	See that it is clean, lightly lubricated, and that both hand wheels work properly.
5. AMMUNITION.	See that ammunition is properly stored, and that boxes and ammunition are in good condition and not oiled.

Table 2-1. Inspection checklist.

f. **Lubrications.** Use cleaner, lubricant, preservative to clean the machine gun. As its name implies, it cleans, lubricates, and preserves all in one application.

(1) After cleaning the gun with CLP, wipe it dry and reapply a thin coating. Allow this thin coat to dry on the parts for a short time before reassembly. CLP deposits a thin coating on the metal which minimizes carbon buildup and prevents foreign material from sticking. It is this coating that provides the frictionless operation of the weapon parts, not liquid oil deposited on them. A gun treated with CLP will operate better and remain clean longer than one treated with any other cleaning material. Use of CLP will reduce maintenance costs and extend the life of the weapon.

(2) Rifle bore cleaner is a cleaning solvent which can be used to clean powder residue, carbon, and dirt from weapons. RBC does not preserve or lubricate a weapon. If you clean a weapon with RBC, dry the weapon and lubricate it with lubricating oil, semifluid (LSA); lubricating oil, special purpose (PL-S); or lubricating oil, general purpose (PL-M). The use of these oils will cause sand or grit to stick to the weapon. RBC and oil should be used only when CLP is not available.

**2-4. MAINTENANCE PROCEDURES**

There are certain actions that must be taken before, during, and after firing to properly maintain the gun. See Table 2-2 for a preoperation checklist.

<b>PART</b>	<b>BEFORE</b>	<b>DURING FIRING OR TEMPORARY CESSATION</b>	<b>AFTER</b>
<b>Bore</b>	<b>Make sure it is clear and clean.</b>		<b>Clean and oil lightly.</b>
<b>Moving parts</b>	<b>Oil lightly and test for worn or broken parts. They should function without excessive friction.</b>	<b>Lubricate working parts. Observe the functioning of the gun to anticipate failures.</b>	<b>Inspect, clean, and oil lightly.</b>
<b>Headspace and timing</b>	<b>Check adjustment by gauge and correct if necessary.</b>	<b>Watch for bulged cases to prevent a ruptured (separated) case. If a separated case occurs, remove it and readjust headspace.</b>	<b>Check adjustment.</b>
<b>Rear sight and windage knob</b>	<b>See that the sight is clean and functions properly. Set sight at 1,000, windage zero.</b>	<b>Keep properly set.</b>	<b>Clean and oil; set at 1,000, windage zero.</b>
<b>Spare parts and tools</b>	<b>Clean and oil spare parts and tools. Check kits for completeness. Examine newly drawn parts.</b>	<b>Keep available.</b>	<b>Clean and oil. Check and replace damaged or missing parts.</b>
<b>Ammunition</b>	<b>Have an adequate supply; clean, correctly loaded, and in good condition. DO NOT OIL.</b>	<b>Keep correctly aligned with the feedway; check resupply. Protect from sun, moisture, and dirt. Watch for link stoppage.</b>	<b>Clean, store carefully, and replenish supply.</b>

**Table 2-2. Operational checklist.**

**2-5. MAINTENANCE UNDER NBC CONDITIONS**

If contamination is anticipated, apply oil to all outer metal surfaces of the weapon. **DO NOT OIL AMMUNITION.** Keep the weapon covered as much as possible. If the weapon is contaminated, decontaminate it as prescribed by FM 3-5 and then clean and lubricate it.

**2-6. GENERAL ASSEMBLY**

To assemble the gun, replace the groups and assemblies in reverse order of their removal in disassembly.

a. **Barrel Buffer Assembly and Barrel Buffer Body Group.** Replace the barrel buffer assembly in the barrel buffer body group, with the key on the spring guide to the right. This key must fit in its slot in the right side of the barrel buffer body. Turn the barrel buffer tube until the screwdriver slot (in the rear of the tube) is vertical and the arrow is pointing to the right. The stud on the tube lock will now engage the serrations in the barrel buffer tube to keep the tube from turning. Push the barrel buffer assembly fully forward (Figures 2- 15 and 2-16).

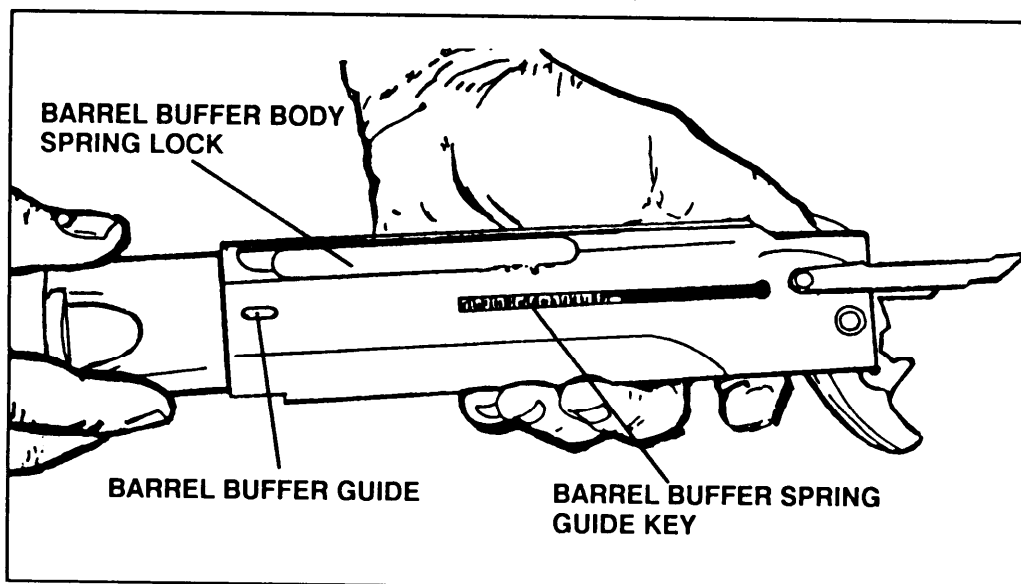

Figure 2-15. Replacing barrel buffer assembly.

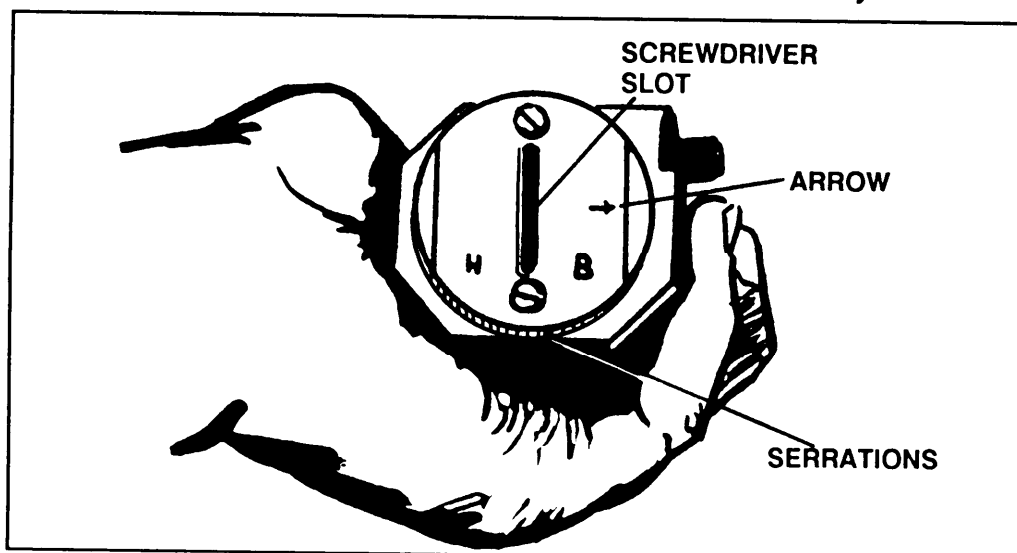

Figure 2-16. Replacing the barrel buffer tube.

b. **Barrel Buffer Group and Barrel Extension Group.** To join the two groups together, hold the barrel buffer group in the right hand, with the index finger supporting the accelerator. Join the notch on the shank of the barrel extension group with the cross-groove in the pistol rod of the barrel buffer assembly. At the same time, align the breech lock depressors with their guideways in the sides of the barrel extension, ensuring that the tips of the accelerator are against the rear end of the barrel extension (claws against the shank) (Figure 2-17). Push the groups together. As the accelerator rotates to the rear, press down on its tips to ensure positive locking of groups. Place the groups in the receiver, and push them forward until the barrel buffer body spring lock snaps into position. When the parts are properly locked in place, the barrel buffer tube should protrude about 1 1/8 inches from the rear of the barrel buffer body group.

c. **Bolt.** Place the bolt in the receiver, with the top of the cocking lever forward and the extractor down. The barrel extension, barrel buffer, and bolt groups may be assembled and returned to the receiver together (Figure 2-18).

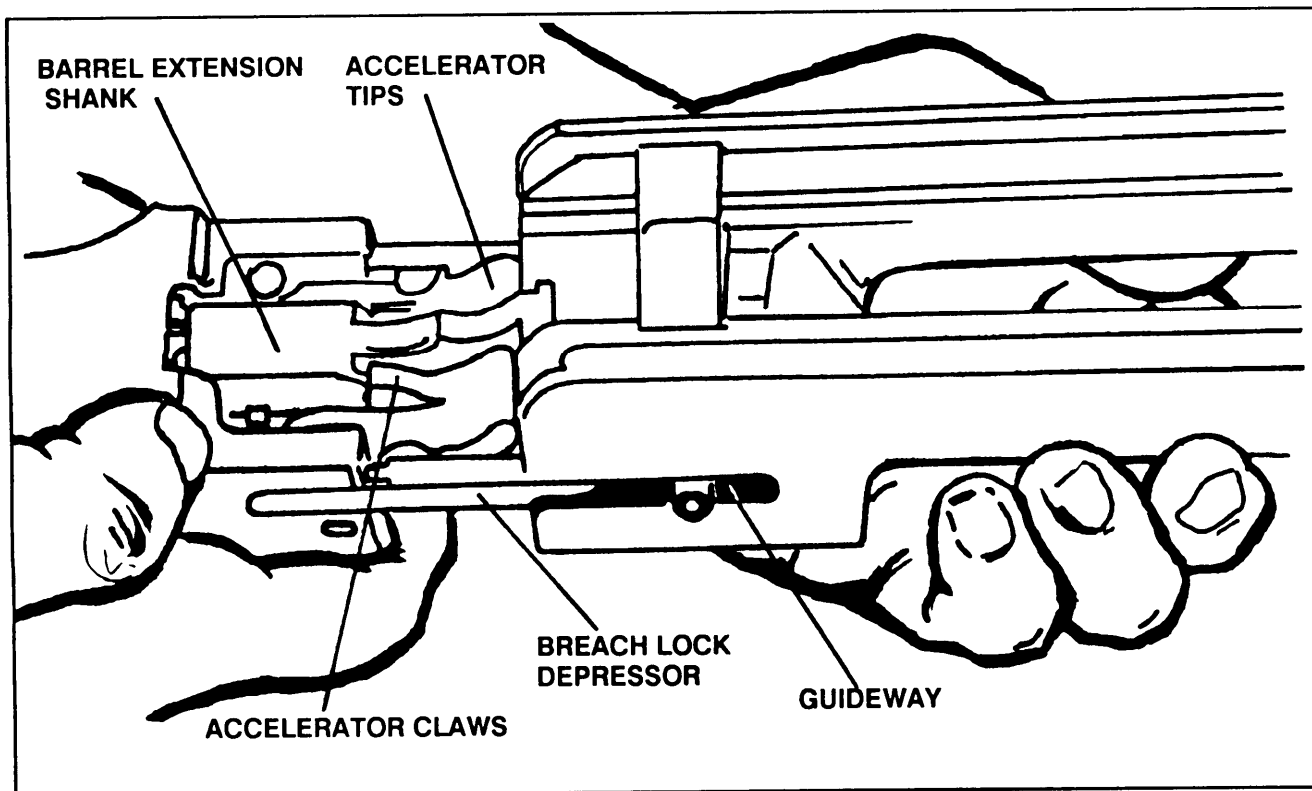
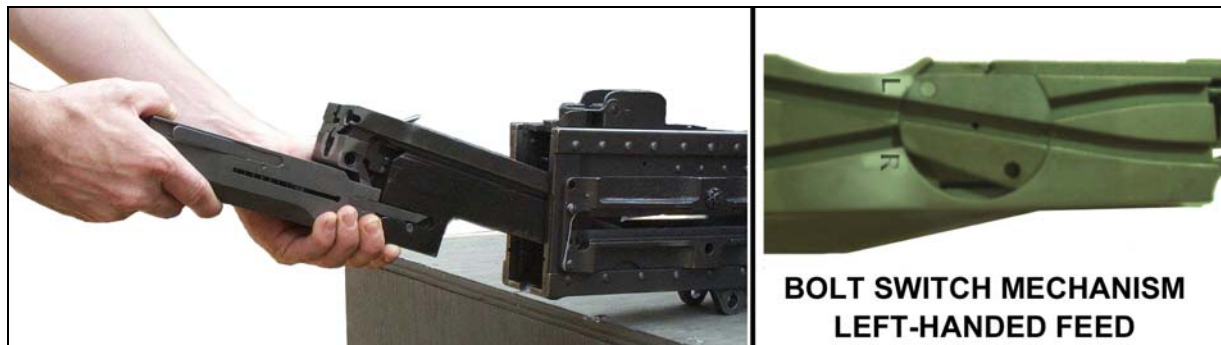

Figure 2-17. Joining the barrel extension group and barrel buffer group.



\* **Figure 2-18.** Returning the barrel extension, barrel buffer, and bolt groups together.

**\* CAUTION**

Before inserting the bolt group, ensure bolt switch mechanism is positioned on **L** (left-hand) feed for the weapon.

- \* **d. Bolt Stud.** Align the stud hole in the bolt with the clearance hole and replace the bolt stud, ensuring that the collar of the stud is inside the sideplate (Figure 2-19).

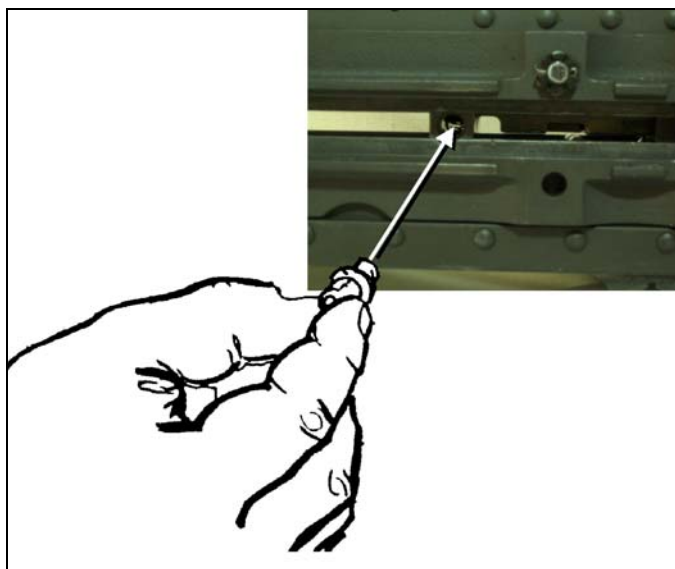

\* **Figure 2-19.** Replacing the bolt stud.

- \* **e. Drive Spring Assembly.** Press up on the bolt latch and push the bolt all the way forward by pushing on the bolt stud only. Place the end of the drive spring rod in its hole in the rear of the bolt, and push forward on the drive spring assembly and the barrel buffer tube. Press in and to the right on the head of the drive spring rod and place the retaining pin in its seat in the right sideplate (Figure 2-20).

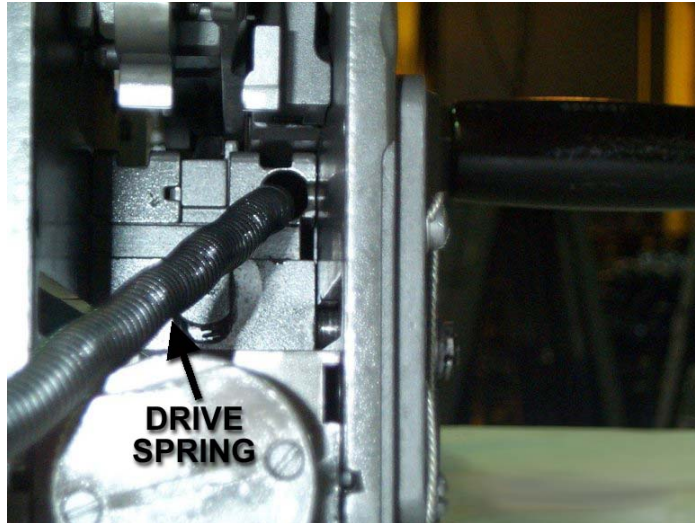

\* **Figure 2-20. Inserting drive spring and drive spring rod (with drive spring rod inside drive spring).**

\* **NOTE:** At this time, the barrel buffer tube should be completely inside the receiver. If not, the barrel buffer body spring is not properly seated.

\* **f. Backplate Group.** Hold the backplate with the latch down and the trigger up; place the backplate guides in their guideways. Hold out on the latch lock and tap the backplate into position until the latch snaps into place (Figure 2-21). Release the latch lock and pull up on the backplate group to ensure it is firmly seated.

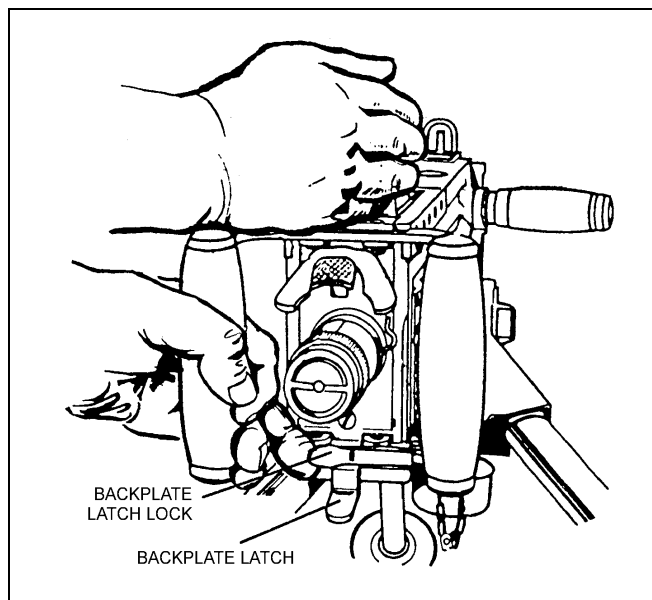

\* **Figure 2-21. Replacing the backplate group.**



**\* CAUTION**

Do not use the driving rod to drive the bolt forward from the rear position. This may damage the drive spring group and cause a stoppage.

- \* g. **Barrel.** Pull the retracting slide handle to the rear until the lug on the barrel locking spring is visible through the 3/8-inch hole in the right sideplate. Place the smallest loop of a caliber .50 link, or suitable spacer, between the trunnion block and the barrel extension. Screw the barrel all the way into the barrel extension; then unscrew the barrel two notches. Remove the link and close the cover. This completes general assembly.

**2-7. FUNCTION CHECK**

A function check must be performed as soon as the weapon is assembled to ensure that the weapon has been assembled correctly. The following procedures should be taken to check the function of the weapon.

- a. Place the weapon in the single-shot mode.
- b. Open the cover and lock the bolt to the rear (bolt should stay to rear while in the single-shot mode).
- c. Hold the retractor handles, press the bolt latch release, and ride the bolt forward.
- d. Press down on the trigger; weapon should fire. (Check T-slot to ensure that firing pin does protrude.)
- e. Place the weapon in the automatic-fire mode
- f. Pull the retractor slide handle to the rear and hold. (Bolt should not lock to rear.)
- g. Release the pressure on the slide handles and ride the bolt forward
- h. Make sure firing pin does not protrude
- i. Press trigger; weapon should fire
- j. Make sure firing pin does protrude.

NOTE: Before firing a newly assembled weapon, first set the headspace and timing. Chapter 3 describes these procedures.