

THIS FILE IS MADE AVAILABLE THROUGH THE DECLASSIFICATION EFFORTS AND RESEARCH OF:

# THE BLACK VAULT

THE BLACK VAULT IS THE LARGEST ONLINE FREEDOM OF INFORMATION ACT / GOVERNMENT RECORD CLEARING HOUSE IN THE WORLD. THE RESEARCH EFFORTS HERE ARE RESPONSIBLE FOR THE DECLASSIFICATION OF THOUSANDS OF DOCUMENTS THROUGHOUT THE U.S. GOVERNMENT, AND ALL CAN BE DOWNLOADED BY VISITING:

[HTTP://WWW.BLACKVAULT.COM](http://www.blackvault.com)

YOU ARE ENCOURAGED TO FORWARD THIS DOCUMENT TO YOUR FRIENDS, BUT PLEASE KEEP THIS IDENTIFYING IMAGE AT THE TOP OF THE .PDF SO OTHERS CAN DOWNLOAD MORE!

AD-A279 968

PAGE

Form Approved  
MB No. 0704-0138



1. AGENCY USE ONLY (Leave blank)	2. REPORT DATE 1993	3. REPORT TYPE Final Report	4. DATE COVERED
----------------------------------	------------------------	--------------------------------	-----------------

5. TITLE AND SUBTITLE Alternative World Scenarios for a New Order of Nations (U)	6. AUTHOR(S) Charles W. Taylor	7. PERFORMING ORGANIZATION NAME(S) AND ADDRESS(ES) Strategic Studies Institute US Army War College Carlisle Barracks, PA 17013-5050	8. PERFORMING ORGANIZATION REPORT NUMBER ACN 93054
---	-----------------------------------	--	---

Alternative World Scenarios for a New Order of Nations (U)

6. AUTHOR(S)

Charles W. Taylor

7. PERFORMING ORGANIZATION NAME(S) AND ADDRESS(ES)

8. PERFORMING ORGANIZATION REPORT NUMBER

Strategic Studies Institute  
US Army War College  
Carlisle Barracks, PA 17013-5050

ACN 93054

9. SPONSORING / MONITORING AGENCY NAME(S) AND ADDRESS(ES)

10. SPONSORING / MONITORING AGENCY REPORT NUMBER

DTIC  
SELECTED  
JUN 02 1994  
S B D

11. SUPPLEMENTARY NOTES

12a. DISTRIBUTION / AVAILABILITY STATEMENT

12b. DISTRIBUTION CODE

Approved for public release; distribution unlimited

13. ABSTRACT (Maximum 200 words)

The author of this futures work presents scenarios appropriate for near- to long-range planning of the activities of the Department of Defense and its agencies out to the year 2020 and beyond. Additionally, the scenarios, because of their design, are useful to other departments of the U.S. Government, industry, business, and academia. Forecasts developed for this report use a technique created by the author for monitoring past, present, and future global trends and events, which he molds into plausible and thought-provoking scenarios of the United States in the world's societies of tomorrow. These plausible scenarios are provided so that users can build policies and make decisions while anticipating and judging their consequences before implementation.

14. SUBJECT TERMS

political, economic, social, technological, and military environments; Alternative World Scenarios; active and reserve components; long-range planning; futures

15. NUMBER OF PAGES

151

16. PRICE CODE

17. SECURITY CLASSIFICATION OF REPORT

Unclassified

18. SECURITY CLASSIFICATION OF THIS PAGE

Unclassified

19. SECURITY CLASSIFICATION OF ABSTRACT

Unclassified

20. LIMITATION OF ABSTRACT

U1

# ALTERNATIVE WORLD SCENARIOS for A New Order of Nations

Charles W. Taylor

DISTRIBUTION STATEMENT B  
Approved for Public Release  
Distribution Unlimited

DTIC  
ELECTE  
JUN 02 1984  
S B D



Strategic Studies Institute  
U.S. Army War College

**ALTERNATIVE WORLD SCENARIOS  
for  
A NEW ORDER OF NATIONS**

**Charles W. Taylor**

**1993**

**DTIC QUALITY INSPECTED**

**94-16365**



**Strategic Studies Institute  
United States Army War College  
Carlisle Barracks, Pennsylvania**

**94 6 1 092**

\*\*\*\*\*

This book is revised and updated edition of *Alternative World Scenarios for Strategic Planning* (Taylor, 1988 and 1990) and is compatible with *A World 2010: A New Order of Nations* (Taylor, 1992).

\*\*\*\*\*

The views expressed in this book are those of the author and do not necessarily reflect the official policy or position of the Department of the Army, the Department of Defense, or the U.S. Government. Research for this book was completed on June 30, 1993. This book is approved for public release; distribution is unlimited.

\*\*\*\*\*

Comments pertaining to this book are invited and should be forwarded to Commandant, U.S. Army College or to the Director, Strategic Studies Institute, U.S. Army War College, Carlisle Barracks, PA 17013-5050. Comments may also be conveyed directly to the author at Box 407 at the above address or by calling commercial (717) 245-3010, DSN 242-3010, or FAX (717) 245-3820.

\*\*\*\*\*

Portions of this book may be quoted or represented without permission, provided that a standard source credit line is included.

\*\*\*\*\*

Cover design by Ms. Roberta M. Hill.

\*\*\*\*\*

<b>Accession For</b>	
NTIS GRA&I	<input checked="" type="checkbox"/>
DTIC TAB	<input type="checkbox"/>
Unannounced	<input type="checkbox"/>
Justification	
By	
Distribution/	
<b>Availability Codes</b>	
Dist	Avail and/or Special
A-1	

# CONTENTS

FOREWORD . . . . .	vii
PREFACE . . . . .	ix
ACKNOWLEDGEMENT . . . . .	xvii
<b>Chapter 1. THE PROCESS . . . . .</b>	<b>1</b>
Introduction . . . . .	1
Methods . . . . .	2
The Cone of Plausibility . . . . .	4
Plausible Scenarios . . . . .	4
Wild Card Scenarios . . . . .	6
Scenario Drivers . . . . .	8
Study Organization . . . . .	10
Addendum . . . . .	15
<b>Chapter 2. THE EARLY DECADES OF THE 21ST CENTURY . . . . .</b>	<b>19</b>
A Common Background . . . . .	19
A New Order of Nations . . . . .	20
Assumptions . . . . .	23
Trends . . . . .	24
A New Arrangement of Nations . . . . .	24
Global Population . . . . .	25
Interdependence . . . . .	27
Social Change . . . . .	30
Energy Sources . . . . .	31
Science, Technology, and Space . . . . .	32
Weapons Proliferation . . . . .	34
Summary . . . . .	35
<b>Chapter 3. SCENARIO SYNOPSES AND ATTRIBUTES . . . . .</b>	<b>43</b>
Introduction . . . . .	43
Finalizing the Scenarios . . . . .	43
Workshop Relationships . . . . .	47

Synopses of the Scenarios in 2020 . . . . .	48
Scenario ALPHA: U.S. Isolationist . . . . .	49
Scenario BRAVO: U.S. World Peacekeeper . . . . .	51
Scenario CHARLIE: Neonationalism World . . . . .	52
Scenario DELTA: Muted Multipolar World . . . . .	54
Attributes of the Scenarios in 2020 . . . . .	56
<b>Chapter 4. THE ALPHA SCENARIOS:</b>	
<b>U.S. ISOLATIONIST . . . . .</b>	<b>59</b>
ALPHA 2005 . . . . .	59
ALPHA 2020 . . . . .	65
<b>Chapter 5. THE BRAVO SCENARIOS:</b>	
<b>U.S. WORLD PEACEKEEPER . . . . .</b>	<b>71</b>
BRAVO 2005 . . . . .	71
BRAVO 2020 . . . . .	76
<b>Chapter 6. THE CHARLIE SCENARIOS:</b>	
<b>NEONATIONALISM WORLD . . . . .</b>	<b>83</b>
CHARLIE 2005 . . . . .	83
CHARLIE 2020 . . . . .	91
<b>Chapter 7. THE DELTA SCENARIO:</b>	
<b>MUTED MULTIPOLAR WORLD . . . . .</b>	<b>97</b>
DELTA 2005 . . . . .	97
DELTA 2020 . . . . .	103
ENDNOTES . . . . .	109
SELECTED BIBLIOGRAPHY . . . . .	117
APPENDIX A. ALPHA 2020: A Miniscenario . . . . .	121
APPENDIX B. BRAVO 2020: A Miniscenario . . . . .	123
APPENDIX C. CHARLIE 2020: A Miniscenario . . . . .	125
APPENDIX D. DELTA 2020: A Miniscenario . . . . .	129
A GUIDE TO ESTIMATIVE SEMANTICS . . . . .	131
ABOUT THE AUTHOR . . . . .	133

# ILLUSTRATIONS

## FIGURES

1. The Cone of Plausibility . . . . .	5
2. The Cone of Plausibility: Past and Future . . . . .	7
3. Alternative World Scenarios for A New Order of Nations . . . . .	11
4. Flow of the Process within the Cone of Plausibility . . . . .	17
5. Potential Advantages Using the Cone of Plausibility . . . . .	18

## TABLES

1. Micro-Scenarios with Potential Drivers for Theme Dominance . . . . .	12
2. Notional Guidelines for Creating Strategic Scenarios . . . . .	13
3. An Arrangement of Nations in 2010-2020 by Industrialization and Modernization . . . . .	22
4. Distribution of Nations by Category, 2010-2020 . . . . .	25
5. Comparative Characteristics of the Categories for A New Order of Nations, 2010-2020 . . . . .	26
6. Distribution of Population by Category in 2010 . . . . .	28
7. Projected Population Estimates by New Order Classification (in Millions) . . . . .	29
8. An Estimate of Political Freedom around 2005 to 2020 . . . . .	31
9. An Estimate of Nations Possessing Nuclear Power Plants in 2020 . . . . .	33
10. Estimates of Nations Possessing Nuclear Weapons and Delivery Means in 2010-2020 . . . . .	35
11. The Probable Occurrence of Selected Trends and Events in A New Order of Nations, 2005-2020 . . . . .	39
12. Scenario Drivers Arranged in Order of Theme Dominance . . . . .	46
13. Comparison of Scenario Attributes for 2020 . . . . .	58



## FOREWORD

This futures book reflects the global trends and events of the recent past and those of today that are bringing about change to the world's political, economic, social, technological, and military environments. The forecasts found throughout the book are derived from analysis of the open literature and other media, the author's experience as a futurist, and his own futures writings.

Since their publication, *Alternative World Scenarios for Strategic Planning* (Taylor, 1988/1990) and its follow-on study, *A World 2010: A New Order of Nations* (Taylor, 1992) have received wide usage for strategic planning throughout active and reserve components of U.S. military. They have also been used nationally and internationally for long-range planning by business, industry, academia, and other private and government organizations. World changes, principally those that have come about since the collapse of the Soviet Union and the decline of Soviet communism, and the consequences of these changes that are unraveling with time, have increased interest in the forecasts of these studies. Further, greater interrelatedness and involvement of nations have encouraged long-range planners and other users to request the author to reassess his earlier writings against this new global setting and produce an updated set of planning scenarios as a sequel to *A World 2010: A New Order of Nations*.

*Alternative World Scenarios for A New Order of Nations* was written by Charles W. Taylor as a text and guide for long-range planners, policymakers, and others. It provides a set of plausible scenarios against which users can build policies and decisions while anticipating and judging their consequences before implementation.

This book was written for the United States Army War College as a contribution to long-range planning for the Army. The Strategic Studies Institute is pleased to publish it.

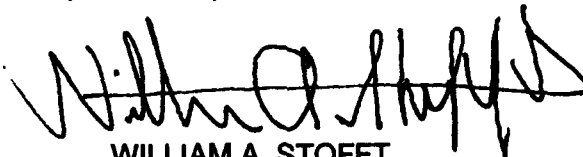

WILLIAM A. STOFFT  
Major General, U.S. Army  
Commandant

## PREFACE

This book is written to provide decisionmakers, policy-makers, long-range planners, and others interested in the future a means to compare the consequences of their actions taken today to plausible, future alternative world environments or scenarios. Earlier work by the author has provided the four basic scenarios which are easily monitored for updating. Scenario updating is a task that is advisable at least every 5 years to maintain the usefulness of the scenarios. The text presented here describes the processes and methods for the creation of alternative scenarios and the use of the Cone of Plausibility (described in *Creating Strategic Visions*, Taylor, 1990) to project the scenarios 10 to 30 years or more into the future. The text also supports and is based on the following two previous writings of the author, *Alternative World Scenarios for Strategic Planning* (Taylor, 1988 and 1990) and *A World 2010: A New Order of Nations* (Taylor, 1992).

Changing trends and the occurrences of associated events (e.g., the demise of the Soviet Union and decline of Soviet communism; the rise of democratic governments; environmental pollution), especially during the last two decades of the 20th century, have created a new era of forced transition for the world's modernized industrial nations. For example, the military of the United States and its defense-oriented industries have been recast into a reformation of conflict/war-based strategies to conflict/peace-based strategies. The military is faced with a forced transition from warfighting missions to missions of peace maintenance: peace-enforcement, -making, -keeping, and -building. Military leaders who view security and defense as an integral part of a strong, but peaceful, economic, and political infrastructure sustained by superior national military strategies increasingly will dominate the U.S. defense rhetoric.

Most industries of the military-industrial complex that are or will be retooling in the late 1990s from defense production to that of domestic, almost certainly will meet the expected

demands of the largely peace-driven national and global economies of the future. From a 20th century view, it would appear that once defense industries have retooled for non-defense production they very likely will be unable to reverse the process easily. From a 21st century view, scientific innovations and technological achievements in the century's first decade almost certainly will have advanced military weaponry and ancillary equipment for warfighting enough to make most of 20th century warfare obsolescent. The retrofitting of 20th century weapons platforms (aircraft, ships, or armored tanks) with 21st century technology almost certainly would be like putting new wine in old bottles.

Economies of the world's nations very likely will no longer be bound by an adversarial political-military relationship of the United States and the former Soviet Union that for nearly 50 years steadily increased defense budgets and national debts. There is little likelihood that the United States or any other nation with large budget deficit problems will overcome them. Expenditures in the so-called peace dividends (former defense expenditures applied to non-defense programs), will likely reduce the deficit only gradually, if at all. During the late years of the 20th century and by 2005 and beyond, nations will have increasing opportunities to establish free-market economies and democratic governments and to increase economic growth, all of which could very likely reduce national debts. Military planners must prepare for the future under current (1994) budgetary reductions, which in comparison to past lush years appear even more austere, through analysis of future world scenarios to determine the extent of the range and types of future conflicts that likely will involve the military. They must also analyze the fit of training, doctrine, and strategy to types of conflict and match technological advancements with conflict strategies.

For this to be accomplished, futurists must construct or synthesize descriptive scenarios from probable future world environments. Planners, in order to identify and understand the challenges that might exist in the future, should make projections of trends from the near future (2-5 years) to the longer range future (20-30 years or more), while evaluating the

impact and interaction of consequences along the way. Trends would include the economic, social, business and industrial infrastructures of a nation or the world, as well as science and technology. This study assists planners and decision makers to view multiple future environments since a single view or projection of a future global environment would be deterministic, i.e., predictive, and would be too chancy.

This study presents four plausible views or scenarios of the global environment of the future in which the United States might exist. The study and the scenarios contain many forecasts. Their purpose is not just to represent one futurist's view of the future, but to bring together four logical and plausible scenarios that are useful to long-range planners. The scenarios are ALPHA, BRAVO, CHARLIE, and DELTA. They appear in synopsis in chapter 3 and in full narrative in chapters 4, 5, 6, and 7. They are presented briefly in the paragraphs below with their descriptive titles.

#### **SCENARIO ALPHA: U.S. Isolationist.**

Scenario ALPHA depicts a relatively peaceful world where the U.S. perception of an external threat is low and the size of its military force is small. The U.S. leadership and its business infrastructure in this international environment have turned toward isolationism. In general, the concerns of the U.S. leadership and its citizens are directed more toward deficit reduction and greater budgetary investments in social welfare, educational, and environmental programs than in programs for space, science and technology, defense, or foreign economic and military aid.

A rise of nationalism throughout many nations of the world, including nations with prior long-term agreements with the United States, has suppressed U.S. international influence and has precluded U.S. military presence overseas. Local U.S. community infrastructures (economies, politics, resources, and demographics) are inhibiting military stationing, training, and installation activities.

The U.S. defense budget has plummeted significantly since the turn of the century. By 2020 the pressures of congressional

environmentalists have forced the closure of many of the remaining military bases that were not closed around 2005. The U.S. armed services have been reorganized into a joint/unified configuration called the General Defense Force (GDF). The warfighting GDF is made up of Land Defense Forces (LDF), Sea Defense Forces (SDF), and Air and Space Defense Forces (ASDF).

### **SCENARIO BRAVO: U.S. World Peacekeeper.**

Scenario BRAVO describes a competitive world of economic trade markets where an undercurrent of external threats and contentions, both economic and military, to U.S. interests are perceptibly increasing. Worldwide, U.S. economic and military assistance agreements are many and are backed by a large U.S. peacekeeping military force. A tradeoff of nationalism for economic development and representative government by many nations worldwide has strengthened U.S. international influence, preserved U.S. investments, and assured the United States of a military presence overseas. The presence of U.S. industries, with their advanced facilities and know-how, is visible and productive in most nations of the world.

Throughout the continental United States, nearly all local communities have accepted military service men and women as part of the community family. Defense budgets are strongly supported by the American public, as are budgets for welfare, education, and the environment. The leadership and citizens of most U.S. local communities underpin and encourage military stationing and installation investments in their neighborhoods without conditions.

Over the past decade or so, the leadership in the U.S. Congresses and the Administrations have advocated a strong military defense. Sizeable and costly military exercises since 2005 continue to be conducted worldwide, some with Russia, the leader of a confederacy named the Union of Sovereign Republics (USR). In BRAVO, the U.S. military budget has increased substantially since the turn of the century because of an apparent increase in a USR threat to world peace. Since

2005, internal ethnic strife and perceived external economic threats have prompted a more aggressive USR leadership to reinforce its military forces.

These potential threats have pressured the U.S. Congress, around 2005, to enact an 18-month National Public Service (NPS) program that includes all agencies of the federal government and provides training for all citizen and noncitizen residents. For the military services, which had been all volunteer, NPS provides a constant source of trained troops.

### **SCENARIO CHARLIE: Neonationalism World.**

The rise of nationalism worldwide in scenario CHARLIE has significantly suppressed U.S. political, economic, and military influence and has eliminated the presence of the U.S. military forces and most American industries overseas. CHARLIE is a highly competitive world where economic trade wars, embargoes, and restrictions abound.

The European Community (EC)\* is experiencing an economic pinch of the nationalistic, worldwide fervor for nations to buy at home. Since around 2005 the EC has perceived no significant military threats to itself, its interests, or to the rest of Europe. With the exception of France and the United Kingdom, all other EC states have demilitarized. NATO became an empty shell nearly a decade ago. The EC and NATO, except for one or two states, essentially, would be unable even to support a peacekeeping force effectively, alone or within a United Nations force, or to quell ethnic conflicts in the EC or in neighboring states. By 2005, nearly all U.S. forces have left Europe except for a few over-manned caretaker contingents and the U.S. forces involved in training exercises in the Union of Sovereign Republics (USR) and the Union of Social Democratic Republics (USDR), confederacies of the former Soviet Union.

External threats to the United States or its interests are more of a challenge to U.S. economic trade and markets than they are threats to political ideology that would call for the use

---

\* As of November 1993 the EC has become the European Union (EU).

of military force. Largely for this reason, the U.S. leadership has provided substantial budgetary support to social and welfare programs and far less to defense. The military budget remains low despite U.S. national political and military leaders advocating a need for a stronger military. This has constrained U.S. security to a small, high-tech, elite military force and has reduced the Defense budget to its lowest level since the 1930s.

A significant portion of the Defense budget is invested into high-tech weaponry and research and development in general. The elite U.S. military forces are organized as the National Defense Forces (NDF). The NDF include all services and are fully capable of land, sea, air, and space operations.

The general public opinion of military service is high. However, partly because of population growth and partly because of military environmental infractions, local U.S. communities do not want military installations in their back yards. Since the military needs only to staff a small force, its source of physically, mentally, and morally fit volunteers for career service is provided through the Universal Public Service (UPS) program of 2003.

Since the late 1990s and the early 2000s, the continued U.S. economic support to Russia and Ukraine (especially), Georgia, and other republics of the former Soviet Union has given these new nations status in the new order of nations. Russia, *circa* 2005, formed a new confederacy with several other former republics and has become the leading republic of the Union of Sovereign Republics (USR). Likewise, Ukraine has become the leading republic of the Union of Social Democratic Republics (USDR).

#### **SCENARIO DELTA: Muted Multipolar World.**

This scenario describes a productive economic world where U.S. political leadership favors social and welfare investments over those of defense. DELTA, however, is a scenario where U.S. local communities increasingly object to military activities at installations in or nearby their communities. The worldwide threat to the United States and its interests is generally perceived by the U.S. leadership to be about the

same as it was in the mid to late 1990s, i.e., more of an economic threat than a military one and with a constant global demand for the United States to prove its global leadership.

Since the turn of the century and by 2020, the military threat emanating from the Union of Sovereign Republics (USR) has steadily grown. The USR is a new confederacy made up of several republics of the former Soviet Union, largely Russia, in about 2003. In 2020 the USR is under a coalition leadership that is an economically aggressive three-party system: democratic, communist, and socialist. The military threat is greater for the European Community (EC) and the other confederacies formed from the former Soviet Union in the first decade of the century than it is for the United States.

The EC, driven by its need for new global economic markets, by 2005 is gaining in economic growth while gradually improving its competitive position globally, especially in the Asian-Pacific Rim markets. U.S. international economic and political influence, during the same time, is being strengthened worldwide by most nations that are making a tradeoff of nationalism for economic growth and are encouraging U.S. trade and tourism.

The reduction of the U.S. military during the past several decades has decreased U.S. presence overseas and reduced the number of local military installations throughout the United States. About 2005, the President combined the Army, Navy, and Air Force into one joint service, primarily to reduce costs and redundancies. The President and the Congress believe that the single joint service will be more responsive to global crises than the services would be separately. The DELTA 2020 military force, organized as a single, Unified Defense Force (UDF), is a mix of generalists and specialists. The UDF has light (easily deployable) high-tech land, air, and sea components for rapid shock attack.

Since the turn of the century the Defense budgets and related programs have been increasingly austere in comparison to past funding of the military in the late 20th century. The national economic benefits of military assistance programs in the DELTA world, however, are mutually satisfying



to host nations and to the United States. These arrangements, i.e., overseas assignments for active and reserve forces, although limited in number, along with other inducements support voluntary military enlistment as the only source of recruitment for the joint service in the DELTA scenario.

## **ACKNOWLEDGEMENT**

Sincere appreciation is extended to the members of the U.S. Air National Guard (ANG) and its contract agency, National Security Analysts Incorporated (NSA), who under the leadership of Major General Philip G. Killey, Director, ANG, participated in a workshop during the summer of 1992 to recommend changes in the text of *Alternative World Scenarios for Strategic Planning* (Taylor, 1988/1990). These recommendations were used to prepare the scenarios of this document and for the writing of the ANG's *Long Range Plan 1993*.

# **CHAPTER 1**

## **THE PROCESS**

### **INTRODUCTION**

This futures study<sup>1</sup> has four objectives. The first is to establish a standard method for Department of the Army (DA) agencies to plan for the midrange to the long-range future through the use of an alternative scenario approach. The second is to describe four future alternative world scenarios (environments) that are plausible, realistic, and appropriate for Army and organizational planning into the 21st century. The third is to revise and update the scenarios to bring them into alignment both with world changes that have occurred since they were published and with the author's recent forecasts.<sup>2</sup> The fourth objective is to adjust the forecasts inherent in the scenarios to accommodate plausible future environments.

The scenarios in this study have broad utility throughout the Army and potential use throughout the Department of Defense (DoD) as well as other government agencies, industries, and academia. The alternative scenario design described here was used in 1986 for a long-range stationing study for the Army in 2020.<sup>3</sup> The design provides a set of four relevant, interrelated scenarios for midrange to long-range planning, policymaking or decisionmaking. Each scenario of the set is multifaceted, holistic, and internally consistent with a time and topic of focus, yet interrelated by design with the other scenarios of the set.

Two time periods are addressed by the scenarios: the years 2005 and 2020. These provide an historical perspective of the future linking 20th century experiences to 21st century requirements, allowing planners to posture for an evolutionary transition of military forces into the 21st century. Further, the scenarios highlight key underlying conditions that may set in motion organizational changes, e.g., in national defense during peacetime. As such, they provide a background for planning

alternative strategic courses of action and for assessing defense and security policies. Equally important, they provide a framework for exploring long-term requirements. Moreover, the alternative scenarios include common parameters that make the most difference to an organization. Planning begins against these common parameters. Once these parameters are defined, organizational subdivisions usually discover unique scenario differences that contribute to the building of a master plan against which decisions can be made and policies set forth.

The advantage of the alternative scenario approach is that it provides a context for planning where a spectrum of trends and concepts can be considered across a variety of settings.<sup>4</sup> Giving each scenario a descriptive title provides a shared reference and common vocabulary for comparisons and discussions among a variety of scenario users.

## **METHODS**

Scenarios, as they are defined for this study, are narratives or outlines that depict preselected future environments at some near or far-off time. They largely consist of knowable things, conditions, and situations in new relationships that when projected into the future evoke new concepts and ideas about change. Although scenarios are neither predictions nor forecasts in themselves, they define future environments and provide insights that allow today's planners, policymakers, or decisionmakers to influence the future. Scenarios are generally semiquantitative or qualitative and judgmental. The validity of the scenarios and methods used to build plausible scenarios can be determined by a consensus of experts<sup>5</sup> or merely by their acceptance and utility by users. A four scenario-package approach is described and developed for this study. It is designed specifically to overcome the deterministic and predictive approach of single-scenario analysis and to provide a more conceptual and probabilistic framework that is plausible.

Within the process of projection there are very distinct dichotomies of terms that are increasingly being accepted by

futurists in the social sciences. One important dichotomy, I believe, is the difference between prediction and forecasting. Prediction, as it is used by some analysts, is a deterministic view of the future, i.e., it is certainty; e.g., tomorrow, it is going to rain. Whereas, forecasting is being used increasingly by futurists as a probabilistic view of the future, i.e., it deals with chance; e.g., tomorrow, there is a 60 percent chance of rain. This difference is important to the development of this book since everyone can predict the future, but no one can predict the future accurately, except by chance. I have taken special care to minimize predicting world conditions in 2020. Moreover, to avoid burdening the reader with numbers, I have made every effort to forecast the future in nominal forecasting terms. For example, the above forecast statement would read: tomorrow, there is a better than even chance of rain. Additionally, I have provided a table of estimative semantics in the back of this book as a guide for the reader to use to determine the probability of the occurrence of trends and events.

The plausibility of the scenarios and the methods created to develop them were originally validated by a seminar conducted by scholars of the J.F. Kennedy School of Government at Harvard University and further supported by the *Harvard Seminar's Executive Summary* and its "Statement of the Seminar Leader," Robert J. Murray.<sup>6</sup> Additionally, since the publication of the *Alternative World Scenarios for Strategic Planning* in 1988, the number of government agencies and private industries using the scenarios for strategic planning supports their acceptance and utility. World events since 1988 have brought about significant changes in international affairs. Many of these changes had been anticipated (e.g., the decline of the superpowers; the turning inward of the Soviet Union for economic reasons; the turning of Eastern Europe toward democracy; and the reduction of U.S. forces at home and abroad) and had been taken into consideration when the 1988 scenarios were written. The early 21st century world environment described in Chapter 2, "The Early Decades of the 21st Century," establishes the background for amending and further developing the scenarios. The scenarios described in this study are extensions and variations of the Chapter 2

environment and reflect the international environment of *A World 2010: A New Order of Nations*.

### **The Cone of Plausibility.**

The scenarios in this futures study encompass a transition of trends and events and their consequences of the last decade of the 20th century and their likely evolutionary change into the 21st century. The planning focus years are 2005 and 2020. The thought process for this transition, or evolution, forms a theoretical cone that encompasses the passage of time, i.e., from the past through today to near or distant tomorrows or futures. Within the cone, cause and effect relationships that define an organization's existence, e.g., the Army's, in response to the external world's characteristics represent trends that can be tracked from today to any point along a time line into the future, while discovering new trends along the way. Although use of the cone does not increase the accuracy of the forecast of the scenarios, tracking in the cone establishes and reinforces the validity and believability of the scenarios and the logic of their development. The process is defined within this theoretical cone where the logical building of plausible scenarios takes place; it is called "The Cone of Plausibility."<sup>7</sup> The cone is displayed in Figure 1 and described in more detail in the addendum to this chapter. The use of this process is a mental exercise of logic that is graphically expressed as an upright cone. It is narrowest at a plane called today, its base, since more is known about today and its immediate future, tomorrow. The cone broadens as knowable futures become increasingly obscure. As the cone extends into time less is known, there are no hard data, and an infinite number of futures exist. Beyond the known futures is where plausible visions of futures or scenarios must be created.

### **Plausible Scenarios.**

Scenarios developed within the cone are considered plausible if they adhere to a logical progression from a starting point to a selected planning focus plane. Plausibility is observed through estimates of the consequences and effects of each scenario's trends and events as they interact

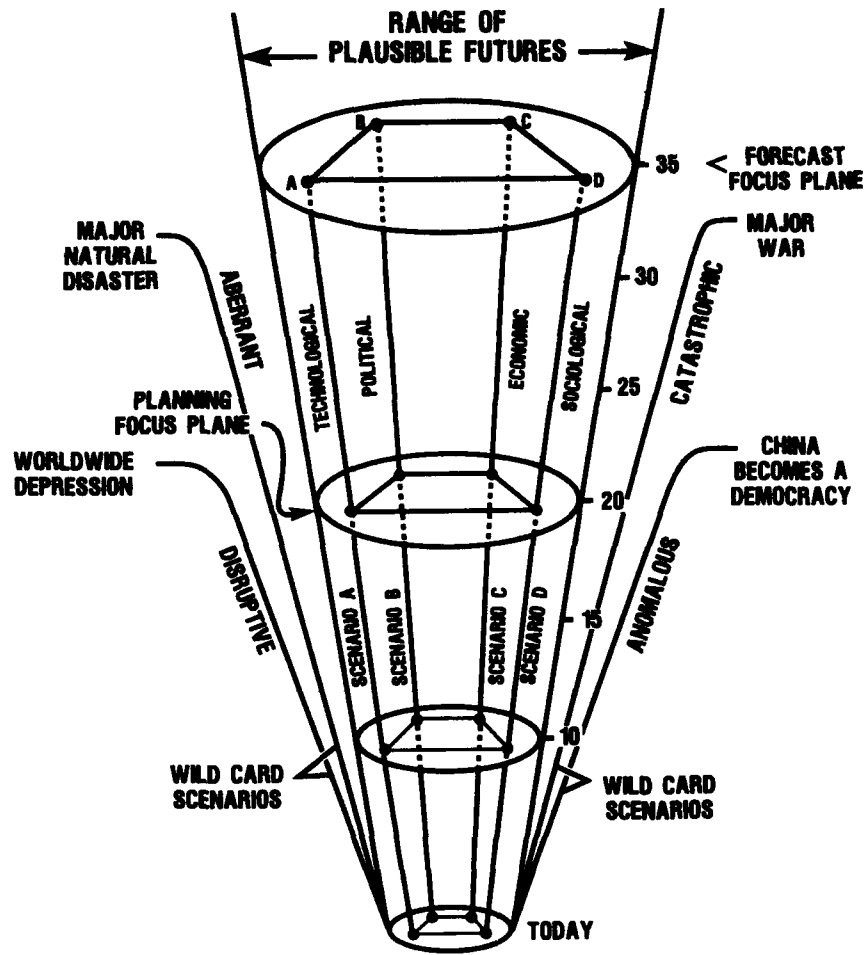

Figure 1. The Cone of Plausibility.

holistically with one another. Moreover, trends and events of each scenario can be tracked backward or forward in the time cone, e.g. from 2020 through 2005 to the 1990s (or earlier) and back to 2020, as a further test of plausibility (see Figure 2). This assures a high degree of compatibility between the past, present, and the future. Ergo, the trends and events and their likely outcomes are intermeshed easily with, and provide guidance direction and orientation for, short-range, midrange, or long-range planning. The process of the cone of plausibility is appropriate and ideal for use by forecasters and planners of governmental, industrial, business, or academic agencies and organizations where logical and plausible observations of trends and events are required.

#### **Wild Card Scenarios.**

Other trends and events and their consequences, when assembled as scenarios, are considered implausible from today's perspective and are called "wild card" scenarios. They are outside of the cone, by definition. They are deviations from the norm. These scenarios encompass major disruptive, aberrant, catastrophic, or anomalous trends and events (see Figure 1). The occurrences of these scenarios, despite variable degrees of warning, are generally not forecast with a high reliability. Wild card scenarios, however, can become operative and quite real at any time, if they do, in fact, occur. When they penetrate the cone, the scenario environments are profoundly altered. Trends and events associated with a wild card event become the dominant drivers of the scenario. They overwhelm the scenario theme. In this event, they would suspend the logical progression of the scenarios established within the cone until new recovery baselines could be determined and new trends and events could be selected as drivers of the scenarios. Wild cards give the cone of plausibility its upright position and conical shape. They are external forces that, theoretically, shape the cone by applying greater pressure against the cone to occur in the very near future, i.e., at the base of the cone, than in the outer years.

The process within the cone of building scenarios is a counterforce to the pressures of the wild cards to disrupt the



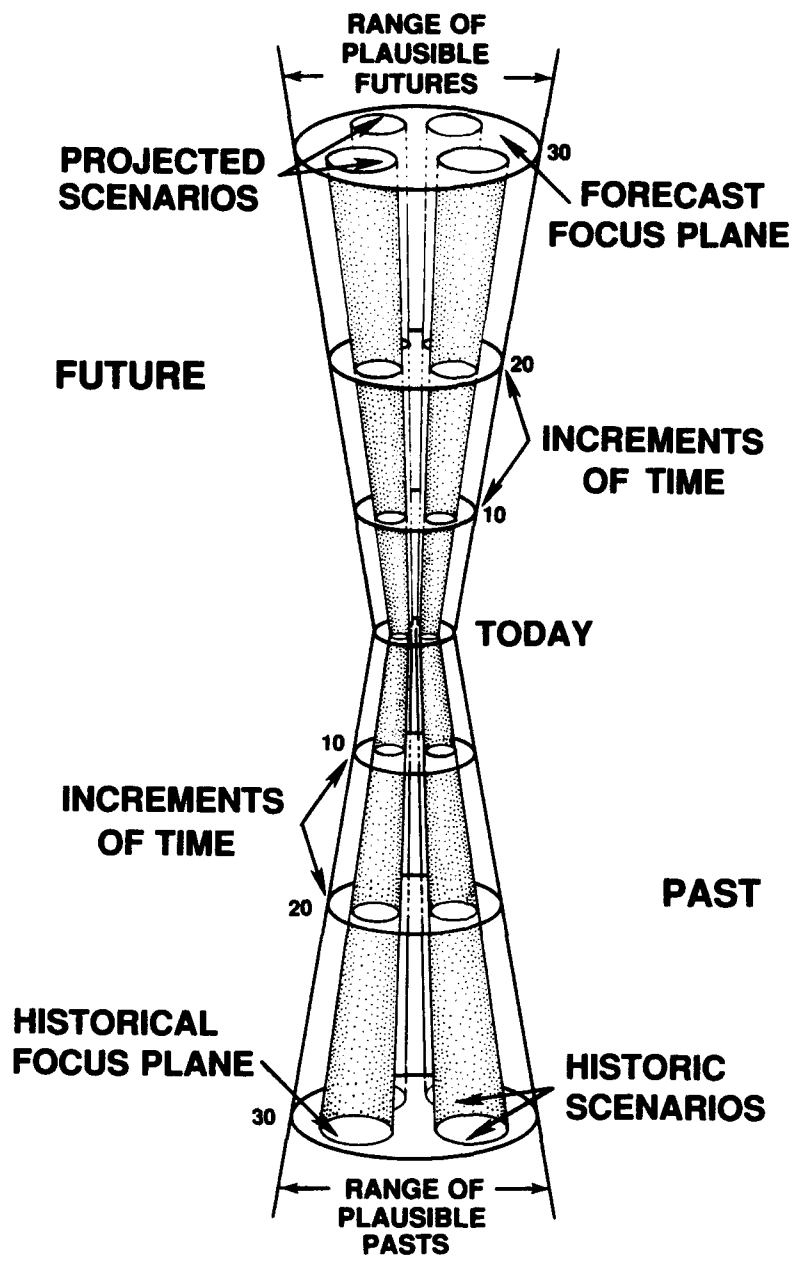

Figure 2. The Cone of Plausibility: Past and Future.

logical sequence and flow of the scenarios outward in time. Wild cards are contingencies. Their occurrence and consequences can be analyzed any time within the cone and might be called digression analysis.

### **Scenario Drivers.**

The trends selected to be the drivers of the scenarios in this study are those that are critical to national and international issues. The trends that shape or drive the future of the United States and its relationships with other nations of the world are the political, economic, social, technological, and military elements of power. Drivers are plausible trends and events associated with these elements, and others, that have varying degrees of dominance and that establish the themes of scenarios. One of these drivers will be selected, placed at the top of the list, and will be dominant over all other driver trends in a scenario. Their interactions create the consequences that move the scenarios outward in the time cone. Four example driver themes—technological, political, economic, and sociological—are depicted in Figure 1 for scenarios called A, B, C, and D, respectively. Examples of drivers or themes that are generally most influential for governments and a variety of businesses and industries are listed at random below:

- Geographic
- Economic
- Military
- Sociological
- Science & Technology
- Demographic
- Political
- Environmental Impact
- Natural Resources
- Community

National and international political and economic drivers were used to set the themes of the scenarios for the Army stationing study. These were selected by the planners and futurist because U.S. national defense is more sensitive to them than to most other drivers, as are most businesses and industries.

Personal experience and research have convinced me that the use of multiple or alternative scenarios improves forecasting accuracy.<sup>8</sup> In order to create four scenarios that were close in relationship to one another, each scenario of the study included driver trends that were similar to those of the other scenarios. The dissimilarities give each scenario a different and distinctive thematic thrust and direction of its environment into the future. When in holistic combination with other scenario trends, the driver trends clearly and dramatically distinguish one scenario from another. Additional discussion of scenario drivers is contained in Chapter 3.

An optimum number of sets of alternative scenarios created by the futurist for a study group of planners is four—each set with four driver statements (see endnote 8). The sets do not include extremes, i.e., upper or lower limits, best or worst case, or middle-of-the-road scenarios. None is intended to be the most or least likely environment or are any forecasts of the world of 2005 or 2020. Rather, each is intended to describe possible combinations of future conditions that can be used as part of a set of considerations for planning or as decision or policy analysis tools.

Notwithstanding the possible independent use of each scenario, the four scenarios were designed to be used as a planning package, where planners and analysts can meaningfully compare the influence of variables across time in realistic situations and in an envelope of potential (not predictive) evolving societal configurations. Use of the scenarios in this study provides users a means by which they can plan realistically for different operating climates, restraints, requirements, and resources for the future. Planners can uncover commonalities and differences as planning form and structure are derived from their analysis. From these

comparisons, final composite plans can be developed. The titles of the four basic alternative scenarios are shown in the cone of plausibility in Figure 3. The scenarios, each with its set of four driver statements, are displayed in Table 1. The scenarios have the following identification and descriptive titles:

- Scenario ALPHA: U.S. Isolationist;
- Scenario BRAVO: U.S. World Peacekeeper;
- Scenario CHARLIE: Neonationalism World; and
- Scenario DELTA: Muted Multipolar World.

Some notional guidelines for generating appropriate scenarios for any subject are suggested in Table 2.

## **STUDY ORGANIZATION**

This study is designed to describe a process for the use of alternative world scenarios for strategic planning purposes by planners and to provide a set of four scenarios that can be used throughout the Department of the Army and other government agencies. The study is presented in seven chapters.

- **Chapter 1, The Process**, provides an explanation of a realistic method to derive sets of plausible world scenarios.
- **Chapter 2, The Early Decades of the 21st Century**, is a background world environment of the early decades of the 21st century from which alternative scenarios can be developed.
- **Chapter 3, Scenario Synopses and Attributes**, describes how the four scenarios were finalized for study purposes and provides a brief synopsis of each of the scenarios for the year 2020 that can be used as a handy reference by the readers and users of this study.
- **Chapters 4, 5, 6, and 7** contain detailed descriptions for each of the scenarios, ALPHA, BRAVO, CHARLIE, and DELTA, for the focus years 2005 and 2020, respectively.

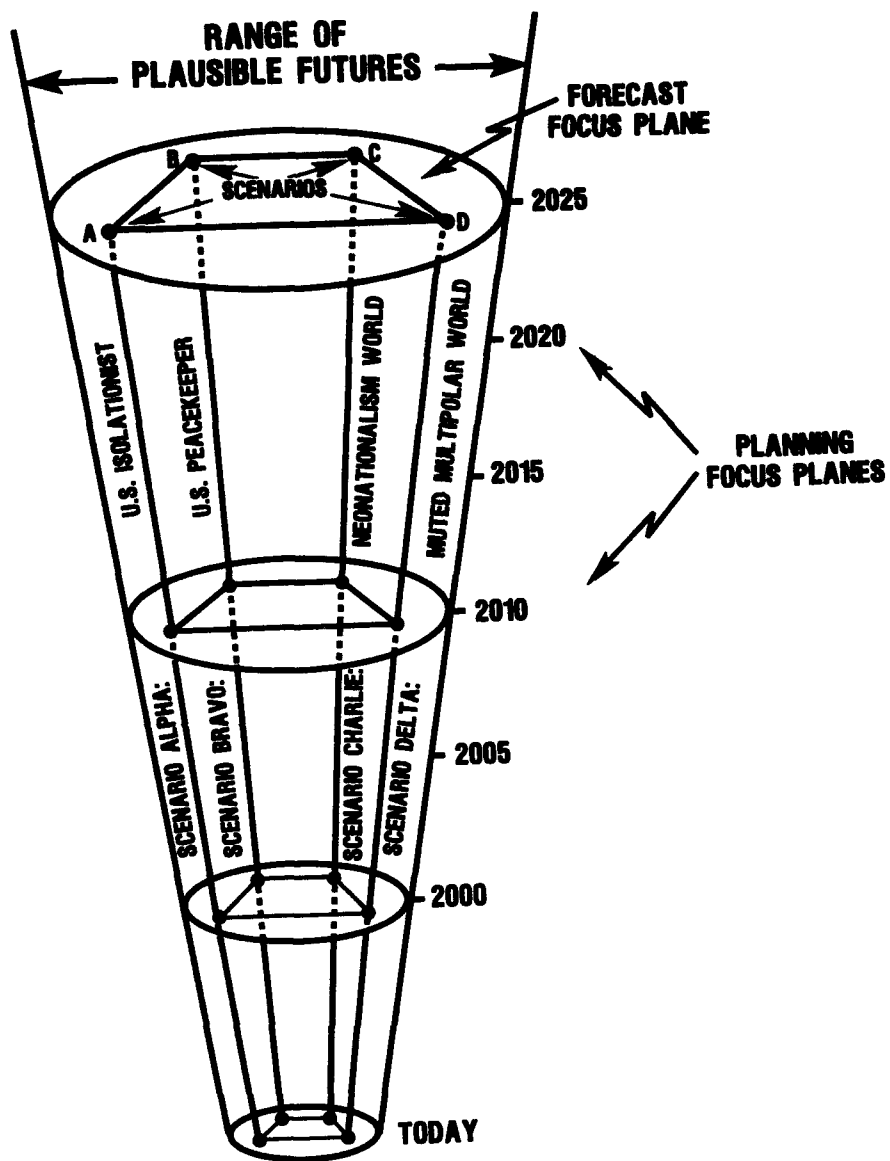

Figure 3.  
Alternative World Scenarios for A New Order of Nations.

**SCENARIO ALPHA:  
U.S. ISOLATIONIST**

U.S. national political leaders advocate a strong welfare and social investment economy.

Postindustrial infrastructures, along with specialty industries, lack the capacity to support industrial surge requirements adequately.

A rise in worldwide nationalism suppresses U.S. influence and precludes U.S. military presence overseas.

U.S. local community infrastructures inhibit military stationing and reduce installation investment.

**SCENARIO CHARLIE:  
NEONATIONALISM WORLD**

U.S. national political leaders advocate a strong military defense.

Postindustrial infrastructures, along with specialty industries, lack the capacity to support industrial surge requirements adequately.

A rise in worldwide nationalism suppresses U.S. influence and precludes U.S. military presence overseas.

U.S. local community infrastructures inhibit military stationing and reduce installation investment.

**SCENARIO BRAVO:  
U.S. WORLD PEACEKEEPER**

U.S. national political leaders advocate a strong military defense.

Postindustrial infrastructures, along with specialty industries, have the capacity to support industrial surge requirements adequately.

Tradeoffs of nationalism for economic development strengthen U.S. influence and preserve U.S. military presence overseas.

U.S. local community infrastructures underpin military stationing and installation investments.

**SCENARIO DELTA:  
MUTED MULTIPOLAR WORLD**

U.S. national political leaders advocate a strong welfare and social investment economy.

Postindustrial infrastructures, along with specialty industries, lack the capacity to support industrial surge requirements adequately.

Tradeoffs of nationalism for economic development strengthen U.S. influence and preserve U.S. military presence overseas.

U.S. local community infrastructures inhibit military stationing and reduce installation investments.

**Table 1. Micro-Scenarios  
with Potential Drivers for Theme Dominance.**

- **Build on Logic and Plausible Assumptions**
- **Focus on Relevant Issues and Interests**
- **Include Valid Trends and Realistic Variables**
- **Challenge Traditional Notions of Structure**
- **Keep Free of Disruptive, Aberrant, Anomalous, and Catastrophic Events (Optional)**
- **Maintain Internal Consistency and Interrelatedness**
- **Create Holistic Visions of the Scenarios**

**Table 2.**  
**Notional Guidelines for Creating Strategic Scenarios.**

## **ADDENDUM**

### **THE CONE OF PLAUSIBILITY**

The cone encompasses the projections of a set of four plausible scenarios, i.e., external worlds and the responses of planners to them. They are identified as A, B, C, and D, and ascend from today to a planning focus plane year of 2020. Although the scenarios individually vary in strength for a particular characteristic, the four scenario package creates a comprehensive political, economic, sociological, and technological holistic set. Each scenario is shown as a point and represents an animated environment at each focus plane. Each scenario ascends along a time line maintaining a continuity through incremental time periods from today to the 2020 focus plane.

Within an incremental time period, e.g., five years, any single trend line may actually be straight, angular, or curved. Trends also may discontinue and be replaced by new trends or combined with others. When the audit trails of all trends in a scenario time increment are combined, the projection, most often, would appear as a straight line. Each successive time increment thus approximates a smooth curve, or straight line, over a thirty-year audit trail of the scenarios. Within any plane there are galaxies of plausible and possible scenarios built from clusters of respective cause and effect relationships. The external world of each scenario on a given focus plane can have any number of plausible planning responses. The fact that each of the designated scenarios, A, B, C, and D, works in concert with the other three captures (mathematically) any other combination of realistic planning responses on a shared focus plane. Various military responses, for example, might be force structure configurations for heavy, medium, and light brigades in percentage; the number of people; and the number of equipment end items at various technology levels, respectively.



## **SCENARIO DRIVERS**

The amount of influence that the drivers may have on U.S. national policies and behavior varies in each scenario. U.S. courses of actions in planning and decisionmaking respond to the influence of the drivers to provide a future architecture for U.S. defense. For example the architecture for the U.S. armies of the future would include specific force structure of the total Army, the Army's end strength, technology (weapons systems and supporting equipment), training strategies, demographic and population shifts, and installation characteristics. Moreover, the drivers likely will influence as well how the Army will be employed in the environment of the future. The drivers also serve as precursors and catalysts to bring about new trends and events that become the forerunners for other future world environments. Each of the basic drivers is given a high probability of occurring in the four scenarios. The purpose is to establish a general scenario theme that can be woven into the environment of each scenario.

The initial scenarios are made up of these basic drivers expressed as brief statements. The number of basic driver statements for this study was narrowed by the author to a set of four relevant and plausible descriptive statements. Each set shapes the conditions and attitudes for expandable scenarios of plausible world environments for 2005 and 2020.

The initial scenarios provide useful tools for establishing a working relationship among experts, planners, and futurists and their scenario writers. Within the flow of the process of the cone of plausibility, it is the experts and planners who provide accurate and relevant input and who will use the final scenarios. The futurists and scenario writers are the ones who provide the forecasts and give consistency and a holistic view to the scenarios. Within the flow of the process, they will gain a better understanding of the level of detail that must go into the final scenarios (see Figure 4). Planners or other scenario users also can participate in the scenario development when the drivers are expressed as statements. The planners' perceptions and comprehension of interrelated effects of the scenario drivers permit them to visualize future possible end

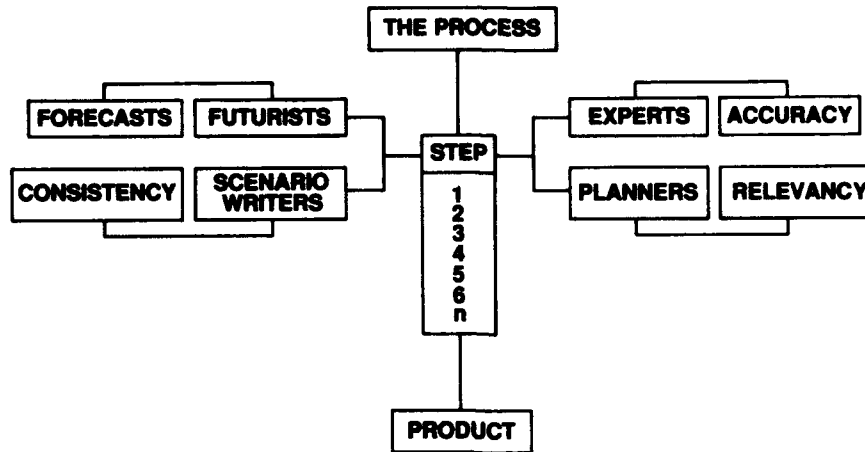

Figure 4.  
Flow of the Process within the Cone of Plausibility.

states for long-range projections that can be used as tentative input to the scenarios. The evolution and plausibility of the scenarios unfold as the basic drivers are expanded and tracked from a starting year through an end-state year, e.g., *circa* 2005-2020.

By using the processes offered by the Cone of Plausibility the following become available: scenario building, the possibility of standardizing forecasting within an organization, and making the methods for forecasting more scientific. Moreover, the thought process used within the cone tends to stimulate users toward goal setting, solution finding, and creativity, as well as uncovering new challenges, all of which build tremendous client (chief executive officer, president, others) confidence in the final product (see Figure 5).

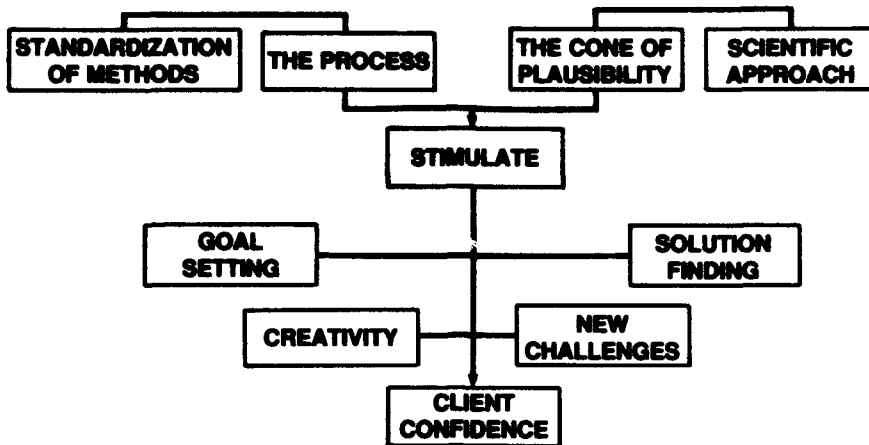

Figure 5.  
Potential Advantages Using the Cone of Plausibility.

## CHAPTER 2

### THE EARLY DECADES OF THE 21ST CENTURY

#### A COMMON BACKGROUND

A large number of potential future world environments emerge from the world as it exists today. Political, economic, sociological, scientific, and technological trends and events are rebounding in heavy activity on a global scale. The concepts and realities of peace and war, rich and poor, love and hate, life and death are confronting all nations, especially the newly emerged independent nations of the late 1990s. The latter nations are seeking self-identity and a destiny of their own in a situation that is increasingly dominated by global and regional economics rather than politics, ideology and military force. Therefore, it would seem that a common framework or background is essential for the development of the scenarios created for this study. Such a framework would be suitable for projections from the near future (2-5 years) to the longer range future (20-30 years or more). *A World 2010: A New Order of Nations* (Taylor, 1992)<sup>1</sup> (hereafter referred to as *A New Order of Nations*), provides an appropriate background scenario for developing the alternative scenarios of this study.

*A New Order of Nations*<sup>2</sup> is an estimate of the world environment as it might be around the year 2010. It is based on the author's projection of the consequences of 20th century trends and events and new trends as they come into being along the way. It takes into account the most current strategic changes in the world's international environment and then forecasts the probability of strategic outcomes that could occur from about 2000 to 2020. The forecasts in *A New Order of Nations* not only provide an adequate starting point for the rebuilding of the scenarios from the earlier 2010 document, (Taylor, 1986),<sup>3</sup> but also provide a basis for constructing the

architecture for U.S. national security strategy and a fitting defense or security force for the future. *A World 2010: A New Order of Nations* is summarized in this chapter. Detailed data that are less strategic or are needed for specific usage of the scenarios, e.g., projected technological advances or demographic data, can be compiled from data found in documents in the open literature.

## **A NEW ORDER OF NATIONS**

In the world of 2010 documents, future environments for the early decades of the 21st century are built upon an evolving hierarchy of nations as they might exist around the years 2005 to 2020 and beyond. Essentially, in the context of these studies and in 21st century terms, there are no superpowers,<sup>4</sup> nor are there nations called Third World.<sup>5</sup> All nations are categorized in terms of their modernization and industrialization. This tends to create status for each nation in the world community or family of nations. Theoretically, having status very likely will increase each nation's self-worth, encourage each to plan and set national goals, and, finally, allow each an opportunity to pursue a more self-directed destiny. Not all nations will be able to do these things by themselves and will look for help from agencies such as those of the United Nations (U.N.) or like organization, and from the world's wealthier leader (postindustrial) nations, e.g., Europe,<sup>6</sup> Japan, or the United States. It is my belief that the 20th century traditional descriptive modifiers for nations, i.e., more developed, developing, less developed countries, and the like, are now and will be inappropriate constructs to describe a ranking of nations for the world of the 21st century.

Nations of the world are aligning in the direction of a new order. This is happening primarily because of the increasing economic and trade relationships and the cultural exchanges in which nations have been engaging. Moreover, the decline of the international power positions of the 20th century superpowers—capped by the fall of the Soviet Union and decline of the Soviet Communist Party—has encouraged many nations of the world to assert their individual concerns for, and interests in, developing their own futures. Imperialism and colonialism, as they have been known in the past, are unlikely

to rise again. Moreover, during the period under consideration in this study, it is unlikely that there will be any nations of the world that will demonstratively seek to fill the world power gaps created by the decline of the superpowers. There are few nations that by mid-21st century would be likely to have a political, military, and economic infrastructure to do this. All nations of the world, however, will continue to recognize that the United States most certainly will remain the foremost leader of the world's nations throughout the early decades of the 21st century.

The new order of nations in the 21st century can be classified into five categories or groups<sup>7</sup> according to their progress in industrialization and modernization (see Table 3). They are postindustrial, advanced industrial, transitioning industrial, industrial, and preindustrial. This chapter includes a brief description of each category.

The arrangement of nations in Table 3 was developed to substantiate the trend that the world is drifting away from political ideological bipolarity to a world of economic multipolarity. The broad latitude created in a devolution of power world allows new economic agreements, alliances, and partnerships to form. It also allows states to achieve new levels of economic statehood; even to be carried along by the rest of the nations of a group. For example, all of the European Community (EC) is categorized as postindustrial, including Albania, Bulgaria, and most of the east European nations—states that are unlikely to achieve such a status on their own. They are symbolically carried along, while being helped by the other European nations to complete the general notion of this 21st century arrangement of nations.

Two new nations appear in Table 3 that must be identified. My belief is that in order for the republics of the former Soviet Union to survive in a highly competitive 21st century economic world, republics with common or like interests and needs will have to group together as new nations. There exists a possibility that of the original 15 former republics, 11 of them (excluding Estonia, Latvia, Lithuania, and Moldavia) of the former Soviet Union, will form three new national confederated entities. These will be tied loosely together by a new

**POSTINDUSTRIAL**

Australia (incl. New Zealand)  
 Canada  
 Europe (EC)  
 Japan  
 United States  
 Union of Soc. Dem. Rep

**ADVANCED INDUSTRIAL**

Hong Kong  
 Israel  
 Singapore  
 South Africa  
 Taiwan

**TRANSITIONING INDUSTRIAL**

Argentina  
 Brazil  
 Chile  
 Costa Rica  
 Mexico

**INDUSTRIAL**

China  
 Cuba  
 India  
 Korea  
 Malaysia  
 Pakistan  
 Philippines  
 Turkey  
 Union of Sovgn. Rep  
 Venezuela  
 Vietnam

**PREINDUSTRIAL**

All other nations of  
 Africa, Asia, Latin  
 America, and Oceania  
 not listed elsewhere.

**Table 3. An Arrangement of Nations in 2010-2020 by Industrialization and Modernization.**

commonwealth created around 2005 that will replace the Commonwealth of Independent States (CIS). For the purposes of this study I have created and named three hypothetical combinations.

- The first nation, a confederation, is the largest in population and geographic area and is classified as an industrial country. I have named it the Union of Sovereign Republics (USR). The common bond that will bring some of the former republics together in this new democratic confederation is primarily the retention of much of each republic's sovereignty. This is something like the relationship of states of the United States to the Federal government, but less like the European Community (EC) where the sovereignty of individual European states continues to be a background issue. The USR leadership is centered in Moscow.

- Another new nation, also a confederation, is about half the size of the USSR in population and geography and is considered marginally a postindustrial country. This nation I have called the Union of Social Democratic Republics (USDR). The USDR includes former Soviet republics that believe they would like to continue some of the former socialist/communist welfare programs within a new democratic government. Its seat of government is Kiev.
- The third new nation, another confederation, is formed from most of the remainder of the former Soviet republics and includes the former autonomous areas and ethnic groups. This group likely will come together as free and independent states. I have called them collectively the Union of Independent States (UIS). The UIS is classified as a preindustrial country and therefore does not appear in Table 3. The seat of government alternates between Tbilisi and Baku.

Other likely configurations of the former Soviet Union, e.g., an economic community, will be defined in the appropriate chapters if needed. Whether there are three, more than three, or less configurations of the former Soviet Union is not important. The logic here is that the republics must join together because individually they cannot survive economically or politically.

## **ASSUMPTIONS**

The assumptions of this study allow the development of both the background and scenario environments during a period of relative peace that extends into two decades of the new century. The assumptions encompass war, world economy, and science and technology. The environments are essentially free of restrictive world societal events, e.g., any natural or manmade event that basically would be so pervasive that it would alter the course of the world. Any such occurrence of catastrophic events affecting the assumptions listed below would create a destabilized world environment in which the trends and events in the scenarios, at most, could not occur or, at least, would be delayed. The assumptions are:



- Neither general war nor a war between the United States and any other militarily equal state, nor a war among other major 20th or 21st century powers will occur before the year 2020.
- Neither a worldwide economic collapse nor major world depression will occur before the end of the 20<sup>th</sup> century or in the early years of the 21st century.
- No major scientific or technological breakthrough(s) will occur that will give one nation the ultimate power of intimidation over all other nations of the world.
- No natural or manmade catastrophic event will occur that will alter the arrangement of nations.

## **TRENDS**

The characteristics of the world environment that are likely to span the period over the next 30 or 40 years are derived, for the most part, from trends of the last half of the 20th century. The environment described in *A New Order of Nations* addresses a period around the year 2010. It is derived from an aggregation of the plausible outcomes of seven basic trends selected for their universal and worldwide influence on almost all nations. These trends, generally recognized by futurists as important to the development of future world environments, are described briefly in this chapter. They are basic strategic trends that can be used by futurists and planners. These trends very likely will continue to impact mankind for at least most of the next century. Moreover, these trends and their consequences create the framework needed to support a common background for the scenarios of this study. The trends include the following.

- **A New Arrangement of Nations.**

*Nations of the world continue to align themselves in a new pattern of international political and economic order.* In the absence of a bipolar superpower dominance based on political ideology, the world's nations very likely will continue to experience a devolution of power in the new century, i.e., a more multipolar world and one that emphasizes economic

ideology. The devolution of global power that likely will evolve will shift increasingly from the 20th century superpower profile to the new order of nations. By 2010 to 2020 the centers of international economic power structure will very likely swing variably from Washington to Berlin, Paris, Singapore, Tokyo, Kiev, Beijing, and Moscow. All nations of the world will remain nation states; none will relinquish sovereignty to any regional or supranational organization. However, they very likely will be members of multinational economic organizations that may or may not be regional. By 2005 new confederacy groups of the former Soviet republics will have established their right to sovereignty and statehood and by 2010 will have organized new economic markets. Although the U.N. remains active, no nation has relinquished its sovereignty to that supranational body. The distribution of the new order of nations within each category is displayed in Table 4. Based on advancements in modernization and industrialization that will come about by 2010 to 2020, some abbreviated statements of comparative characteristics that describe each category are shown in Table 5.<sup>8</sup>

• **Global Population.**

*Global population continues to increase.* Demographers estimate that by the year 2020 world population will have increased by greater than 35 percent over the 1990s. Many nations will have slowed their rate of population growth by the

Approximate No. of Nations	Nation Status	Percent of All Nations
115	Preindustrial	68
32	Postindustrial	19
11	Industrial	7
5	Advanced Industrial	3
5	Transitioning Industrial	3
168	Total	100

Table 4.  
Distribution of Nations by Category, 2010-2020.

Societal Structure	CATEGORIES:				Preindustrial
	Postindustrial	Advanced Industrial	Translating Industrial	Industrial	
Industrial orientation	Ultramodern, science-based/high-tech oriented for information, service, and knowledge industries; maximum use of space	Highly modernized, automated and robotic 21st century manufacturing including the use of space	Modernized industrial/manufacturing and agriculture mostly 21st century	Modern, late 20th century industrial manufacturing and agriculture	Partly industrial to almost completely agriculture
Work force (percent of workforce)	Information 33% Knowledge 32% Services 15% Light manufacturing 18% Technoagriculture 2%	High-tech manufacturing 35% Light and heavy manufacturing 25% Services 10% Technoagriculture and agriculture 30%	Manufacturing 30% Light and heavy industry 30% Agriculture 30% Services 10%	Manufacturing 15% Light and heavy industry 45% Agriculture 30% Services 10%	Light and heavy industry 30% Agriculture and extractive processes 65% Services 5%
Political freedom	6 nations: 100% free 0% partly free	5 nations: 20% free 80% partly free	5 nations: 80% free 20% partly free	11 nations: 27% free 64% partly free 9% not free	115 nations: 32% free 32% partly free 36% not free
Military forces	Small active forces. Large general purpose reserve; high-tech trained; most advanced weapons in the world.	Large active highly mobile forces; small reserve force; sophisticated training; technology-oriented; advanced conventional and some nuclear weapons.	Small active and reserve forces; well trained defensively; advanced, sophisticated conventional weapons and some with modest nuclear weapons; Mexico and Costa Rica less capabilities.	Large (relative to country) armed forces; most are highly trained; mix of advanced and modern weapons; USA and China weapons nearly the same as post-industrial nations.	Small active forces; poorly trained; mix of antiquated and advanced weapons; some with few to no forces or weapons at all.

Table 5. Comparative Characteristics of the Categories for A New Order of Nations, 2010-2020.

year 2005 while some others very likely will be approaching zero growth by 2020. Still others, where starvation had been prevalent before the turn of the century, will have gone bankrupt; while others will have failed in nationhood and no longer exist despite international aid from the U.N., supranational organizations, and others. The population growth of other nations, however, although slightly reduced from that during most of the 20th century, will continue at a high rate. The increasing population growth in urban areas will significantly add to societal change as well as to new urban crime and social strife, much of which very likely will involve international crime syndicates. Transnational migrations of large numbers of unemployed, unemployable, and impoverished peoples to the more industrialized nations after the turn of the century increasingly will burden these countries also with crime and strife.

The world's population distribution by the year 2010 is displayed by category in Table 6. The distribution by 2020 throughout the new order of nations of an estimated 8.0 billion world population can be extrapolated from Table 7.<sup>9</sup>

• **Interdependence.**

*Interdependence among the world's nations continues to increase but in new patterns of political, economic, and cultural arrangements and competition.* The growth of interdependence along with new economic treaties and trade arrangements among nations between 2005 and 2015 very likely will have caused a general abandonment of 20th century trade agreements; increases in the adoption of the free-market and enterprise systems; creation of an acceptable common currency throughout Europe; and rises in economic growth for most nations of the world.

The new order of nations almost certainly will evolve gradually into a world economy that, for most nations, will generate greater wealth. The resulting redistribution of the world's wealth will especially benefit the transitioning industrial and industrial countries, while simultaneously lessening the economic influence of the 21st century postindustrial countries. Inequality in the redistribution, however, likely will increase in

<b>Percent of World Pop.</b>	<b>Nation Status</b>	<b>Population (In Billions)</b>
48	Industrial	3.36
30	Preindustrial	2.10
16	Postindustrial	1.10
5	Transitioning Industrial	0.37
1	Advanced Industrial	0.10
100	World Population	7.04

**Table 6.**  
**Distribution of Population by Category in 2010.**

the resource-rich preindustrial countries—with the rich becoming richer faster than the poor become rich. Foreign capital investments will be sought by the transitioning industrial and industrial states from the postindustrial and advanced industrial countries. Such arrangements will become increasingly more acceptable, will create a new capital flow, and will be a positive step toward increasing free enterprise in these countries. Worldwide economic stagnation is unlikely in the 2010 scenario.

The resource-rich preindustrial countries very likely will require economic assistance by 2010 due to poor financial management, new sources of competition, and because they believe their resources are beginning to show signs of depletion. Such economic aid most likely will be provided, in part, competitively by the industrial countries in return for bilateral, preferential access agreements and, in part, by the postindustrial nations, especially the United States, to sustain some vestige of economic influence. This intense competition for scarce natural resources, needed by almost all the modernized countries, will keep the cost of these resources high. The uneven natural distribution of these resources, found mostly in the single industry preindustrial countries, makes the resource-poor preindustrial countries even poorer. Without continued economic aid (emergency and survival) from the International Monetary Fund, the World Bank, U.N. agencies, and charitable organizations in the form of money, credit, food

	1986	1993	2010	2025
<b>WORLD</b>	<b>4,948.0</b>	<b>5,508.0</b>	<b>7,041.0</b>	<b>8,425.0</b>
<b>POSTINDUSTRIAL</b>	<b>994.7</b>	<b>1,046.1</b>	<b>1,101.3</b>	<b>1,133.8</b>
North America	267.0	287.0	331.0	371.0
Europe (EC)	493.0	513.0	523.0	516.0
Japan	121.5	124.8	130.4	125.8
Australia & New Zealand	19.1	21.2	24.8	27.1
Union of Soc. Dem. Rep.	94.1	100.1	92.1	93.9
% of world population:	<b>20.1</b>	<b>19.0</b>	<b>15.6</b>	<b>13.5</b>
<b>ADVANCED INDUSTRIAL</b>	<b>65.3</b>	<b>73.8</b>	<b>96.1</b>	<b>112.7</b>
Hong Kong	5.7	5.8	6.3	6.2
Israel	4.2	5.3	6.9	8.0
Singapore	2.6	2.8	3.2	3.3
South Africa	33.2	39.0	55.9	70.0
Taiwan	19.6	20.9	23.8	25.2
% of world population:	<b>1.3</b>	<b>1.3</b>	<b>1.4</b>	<b>1.3</b>
<b>TRANSITIONING INDUSTRIAL</b>	<b>271.2</b>	<b>292.3</b>	<b>365.5</b>	<b>412.8</b>
Argentina	31.2	33.5	39.9	44.6
Brazil	143.3	152.0	185.6	205.3
Chile	12.3	13.5	17.0	19.8
Costa Rica	2.7	3.3	4.5	5.6
Mexico	81.7	90.0	118.5	137.5
% of world population:	<b>5.5</b>	<b>5.3</b>	<b>5.2</b>	<b>4.9</b>
<b>INDUSTRIAL</b>	<b>2,397.1</b>	<b>2,717.7</b>	<b>3,362.1</b>	<b>3,887.3</b>
China	1,050.0	1,178.5	1,397.8	1,546.3
Cuba	10.2	11.0	12.3	12.9
India	785.0	897.4	1,166.2	1,379.6
Korea	63.8	67.2	80.2	86.9
Malaysia	15.8	18.4	26.0	33.5
Pakistan	101.9	122.4	190.7	275.1
Philippines	58.1	64.1	85.5	100.8
Union of Sovgn. Rep.	180.2	185.0	202.3	213.6
Turkey	52.3	60.7	81.8	98.7
Venezuela	17.8	20.7	27.6	32.7
Vietnam	62.0	71.8	91.7	107.2
% of world population:	<b>48.5</b>	<b>49.4</b>	<b>47.8</b>	<b>46.1</b>
<b>PREINDUSTRIAL</b>	<b>1,219.7</b>	<b>1,397.2</b>	<b>2,102.4</b>	<b>2,866.9</b>
Africa	549.8	638.0	1,025.1	1,482.0
Asia	560.5	616.4	884.5	1,149.4
Latin America	119.8	136.0	183.6	223.6
Oceania	5.9	6.8	9.2	11.9
% of world population:	<b>24.7</b>	<b>25.4</b>	<b>29.9</b>	<b>34.0</b>

Table 7. Projected Population Estimates by New Order Classification (in Millions).

and other goods, many of the poorer preindustrial countries will face the prospects of internal upheaval, bankruptcy and complete collapse and, eventually, disappearance as nations.<sup>10</sup> These nations likely could survive their increasingly dire situations provided supportive, long-term economic aid, once given, is continued. The application of agro-technology likely could provide both food and employment for their people as well as their survival as nations. The destiny of these countries will lie more in the elimination of war and strife than it will in the unavailability of food as a source of famine and extinction.<sup>11</sup>

- **Social Change.**

*Sociopolitical changes increasingly are affecting all nations of the world.* Between 2000 and 2005, most of the world's nations can be expected to have experienced a sociopolitical reorientation. These changes or experiences very likely will reflect the new status in the international order of nations as well as a general relaxation of world tensions. Nations and their leadership very likely will form new views of, and make modifications to, political processes and social structures as new industrial, economic, and technological infrastructures come into being within most nations. The spread of free enterprise on a worldwide scale increasingly will promote a rise in capitalism along with an increase in privately owned and controlled industries. Moreover, the influence of a free-market system,<sup>12</sup> very likely, will encourage a growing preference by many people for representative government and the recognition of human rights and social justice.<sup>13</sup> Such changes in political and economic systems that increasingly are occurring in nations of the world can be described as they relate to each nation's political and civil freedoms (see Table 8).<sup>14</sup>

Nations increasingly will be rated by other nations for political and civil freedoms where a politically free baseline is a fully competitive electoral process and those elected clearly rule; where the baseline of civil liberties is where freedom of public expression for political change is not closed; and where courts protect individual expression. Also included in Tables 5 and 8 is a partly-free category where there is overlapping of either political or civil freedoms, and a not-free category where

Category	Nations		Free		Partly Free		Not Free	
	No.	%	No.	%	No.	%	No.	%
Postindustrial	32	19.0	29	17.3	3	1.8	0	0.0
Adv. Industrial	5	3.0	1	0.6	4	2.4	0	0.0
Trans. Industrial	5	3.0	4	2.4	1	0.6	0	0.0
Industrial	11	6.5	3	1.8	7	4.2	1	0.6
Preindustrial	115	68.5	37	22.0	37	22.0	41	24.4
Totals:	168	100	74	44.0	52	31.0	42	25.0

**Table 8.**  
An Estimate of Political Freedom around 2005 to 2020.

governments are authoritarian and individual rights and freedoms are denied. There is a good chance that by 2010 even China will become partly free as it increasingly recognizes individual freedoms and blends free enterprise within a controlled economy and social democracy with communism after the turn of the century. Through the early decades of the new century, most of the nations of the world can expect cultural and philosophical changes that most likely will continue to alter their societies profoundly. Unless technology can provide remedies, however, ignorance and apathy are likely to result in new geographical patterns of pollution in and around the newly industrial countries (NIC). Paradoxically, a new growth of nationalism can be expected also to arise in most nations, which very likely will weaken 20th century world cooperative movements, international organizations, and alliances. On the up side, the spread of free enterprise worldwide increasingly will promote a continuing rise of capitalism and civil and political freedom, while on the down side, there is a good chance of a rise in terroristic acts that will alter the progress of some nations.

• **Energy Sources.**

*Reserves of petroleum, primarily, and gases continue to decrease as sources of energy while the use of coal, nuclear, and alternative energy sources rises. Sometime before the end of the 21st century, barring any major discoveries of oil in China, in the former Soviet Union, or from offshore drilling,*



there is an even chance that conventional oil reserves of the world could be moving toward depletion.<sup>15</sup> If this trend is valid, then, around the year 2010, nations of the world can expect that the cost of pure oil and oil with added extenders very likely will become increasingly prohibitive for any practical use. The new order of nations with more industrial countries probably will continue to depend on oil at least through the early decades of the new century. The source of oil during this period most likely will be from several suppliers, such as the 20th century Organization of Petroleum Exporting Countries (OPEC), if it remains in existence; an OPEC-like cartel and splinter cartels; or independent oil-rich countries. To replace oil as a source of energy production, the use of coal, gas, nuclear and renewable energy sources almost certainly will increase substantially over the long term—especially coal.<sup>16</sup>

Toward the year 2010, most of the postindustrial, advanced industrial, transitioning industrial, some of the industrial, and a few preindustrial countries increasingly will expand or begin their use of nuclear power as an energy source. Despite legal, technical, and high-cost setbacks, plus the shutdown of a few plants because of age, and notable accidents (e.g., the U.S. "Three Mile Island" incident, the Soviet Chernobyl catastrophe, and others), there is little likelihood that nations will abandon existing operational or planned nuclear power plants as the primary source of energy in the new century. As gas and fuel prices increasingly rise, nearly all nations will become aware that fossil fuels, oil and gas supplies very likely will be approaching depletion during the latter half of the 21st century leaving many nations dependent on coal and nuclear power for energy sources. By 2020, about 40 nations (as displayed in Table 9)<sup>17</sup> may have acquired or restored nuclear power plants to satisfy most of their energy needs.

- **Science, Technology, and Space.**

*Science and technology continue to advance rapidly as do space exploration and use.* Most nations of the world by 2010 will be benefiting from the continuing great strides in the advancements of science and the achievements of technology. All nations will be sharing in this progress; even the poorest of the preindustrial states, although they will continue to receive

**POSTINDUSTRIAL**

Austria  
 Belgium  
 Bulgaria  
 Canada  
 Czech Republic  
 Finland  
 France  
 Germany  
 Hungary  
 Italy  
 Japan  
 Netherlands  
 Poland  
 Romania  
 Spain  
 Sweden  
 Switzerland  
 Union of Soc. Dem. Rep.  
 United Kingdom  
 United States

**ADVANCED INDUSTRIAL**

Israel  
 Singapore  
 South Africa  
 Taiwan

**TRANSITIONING INDUSTRIAL**

Argentina  
 Brazil  
 Chile  
 Mexico

**INDUSTRIAL**

China  
 Cuba  
 India  
 Korea  
 Pakistan  
 Philippines  
 Union of Sovereign Republics  
 Vietnam

**PREINDUSTRIAL**

Egypt  
 Iran  
 Iraq  
 Saudi Arabia

**Table 9. An Estimate of Nations Possessing Nuclear Power Plants in 2020.**

the most advanced appropriate technology<sup>18</sup> from benevolent nations and world organizations. By the turn of the century, the transfer of technology, including technical information and equipment, is very likely to be unimpeded to all states that have the economic and societal infrastructures to afford its costs, understand its complexity, and absorb the societal changes it causes. Some nations, however, will not be able to understand the complexities nor be able effectively to absorb and apply 21st century technology within their societies. Such situations likely will result in societal frustrations and adverse reactions not just against the technology, but against its source as well.

As for space, there is a good chance that many nations that could not afford the benefits of space in the 20th century will be able to buy portions of satellite and shuttle activities after

the turn of the century. Almost all nations increasingly will profit from the peaceful commercial and exploratory use of space. Several exploratory space programs will be shared in the joint efforts of the United States and the USSR, e.g., a manned Mars expedition. The cost-benefits of such developments and activities by 2005 to 2020 most likely will outweigh the uncertainties and risks of military weapon systems or missile defense systems in space.

• **Weapons Proliferation.**

*Proliferation of conventional, chemical, biological and nuclear weapons continues.* Despite the reduction of world tensions, almost every industrial nation will be armed with a range of conventional, chemical, and biological weapons. Most of these weapons will have been supplied to them by the EC, the United States, and China before the year 2005; by several of the former Soviet republics before and after their reorganization as new states; and by new 21st century weapons manufacturing nations. Many nations will continue to purchase or barter for the latest conventional high-tech weapons, which will be available from new 21st century arms suppliers. Additionally and more importantly, by the end of the first decade of the century, nuclear proliferation will have increased.<sup>19</sup>

Most nations, except the very poorest, very likely will demand the most advanced conventional systems they can afford to buy. They almost certainly will find a broader as well as different source of arms suppliers available than existed before the turn of the century. Hence, with this likely increase in the possession of weapons, the potential for conflict almost certainly will be high and continue to rise. There is a good chance that the proliferation of nuclear weapons will continue despite the increased number of signatories to the Nuclear Non-proliferation Treaty.

Table 10<sup>20</sup> is based on the hypothetical criteria that some nations perceive a need to have nuclear weapons in their arsenals; some will have a capability of producing their own, and others will have the means to acquire them surreptitiously. Their need might arise from a real or imagined threat, or a belief

that possession of nuclear weapons raises their international status, or just because their neighbor has them. Chances are better than even that by 2010-2020 the number of nations acquiring a military nuclear capability could approach 24 or more. Thus, there is, at most, an even chance that a nuclear weapons accident, nuclear blackmail, or a limited nuclear conflict between small nations, e.g., preindustrial and newly industrialized countries (NIC), will occur within the early decades of the 21st century. Chances are almost certain that if proliferation of ballistic missiles and nuclear weapons is not halted in the very early years of the century, not only will the potential for accident or conflict increase, but so will the direct or indirect involvement of other nations as well.<sup>21</sup> Chances are

<b>POSTINDUSTRIAL</b>	<b>INDUSTRIAL</b>	<b>ADVANCED INDUSTRIAL</b>
France <sup>1</sup>	China <sup>1</sup>	Israel <sup>2</sup>
Germany <sup>3</sup>	India <sup>2</sup>	South Africa <sup>2</sup>
Japan <sup>3</sup>	Korea <sup>3</sup>	Taiwan <sup>3</sup>
USDR <sup>1</sup>	Pakistan <sup>2</sup>	
United Kingdom <sup>1</sup>	USR <sup>1</sup>	
United States <sup>1</sup>	Vietnam <sup>4</sup>	
		<b>PREINDUSTRIAL</b>
<b>TRANSITIONING INDUSTRIAL</b>		Egypt <sup>5</sup>
Argentina <sup>4</sup>		Iran <sup>5</sup>
Brazil <sup>4</sup>		Iraq <sup>5</sup>
Chile <sup>4</sup>		Libya <sup>5</sup>
		Saudi Arabia <sup>5</sup>
		UIS <sup>?</sup>

---

1 = substantial, 1,000 or more; 2 = significant, 1,000 or less;  
 3 = moderate, 500 or less; 4 = modest, 100 or less; 5 = very modest, 50 or less;  
 ? = number unknown.

**Table 10. Estimates of Nations Possessing Nuclear Weapons and Delivery Means in 2010-2020.**

only slightly better than even that the proliferation of nuclear weapons alone will deter their use.

## **SUMMARY**

This chapter has described a new order of nations that almost certainly will contribute toward a devolution of international power. The chapter also provides a base-line world scenario for the building of alternative scenarios. More importantly, this chapter suggests that new patterns of political and economic competition and cooperation among nations of the new order very likely will contribute toward a new intensity of international free trade and competitiveness. Notwithstanding, many new international relationships and arrangements are likely to emerge in the early decades of the century. Despite a period of relative peace and calm, collusion on the part of some nations, along with some international economic market chicanery on the part of others, likely will be a common practice during the early years of the new century. For better or worse, the superpowers of the 20th century were role models for many nations. Each had its followers. Each was sought by other nations for political, economic, or military guidance and support. Even by 2010, many nations will not have as yet adjusted to the absence of the competitive leadership of the superpowers. The devolution of power has brought about new economic and political relationships among the six postindustrial and all other nations of the world.

By the turn of the century, the United States will be the accepted leader of the postindustrial states. And, although by 2010 it likely will find its 20th century international position of influence somewhat diminished, the United States will remain the preeminent world leader. However, other postindustrial states, many of which were once traditional U.S. allies linked directly by security commitments, very likely will become even greater competitors for political influence and economic markets than they were in the past. Moreover, the United States might find its need for national and economic security occasionally challenged by these conscientious competitors who are bent on grasping the international industrial influence previously held over the past half century by the United States. There is a very good chance that a few of the industrial and newly industrialized countries (NIC) will make a rigorous and substantial effort to fill that gap. The United States very likely

will retain its international position in political and economic influence through its status as the world's leader in services, information and knowledge.

The world in the early decades of the 21st century, as described in this chapter, is a world of a new international order where many nations, formerly centrally controlled and communist, have become free societies with free-market economies. Together, the world of 2010-2020 might appear to be a relatively peaceful world. However, it is a world where political and economic stability is fragile; a world that is fraught with threats of crises, armed conflicts, and possibly wars among, between, and within nations.

There is a good chance that the USSR will be ill content to remain an industrial country in the new order of nations; while the USSR and its 20th century rival the United States advance beyond the USSR's national capabilities. The USSR leadership very likely will depend heavily on political and economic agreements with the European nations and the United States. Moreover, the USSR leadership likely will depend on considerable assistance from the European Community (EC) in the early years to help them develop sufficient economic capabilities to become a transitioning industrial nation. The USSR very likely will continue national introspection to avoid what could be gradual national fragmentation, dissolution, or a return to state controlled government. During the next 10 or more years, the USSR will be forced to devote more of its national assets toward creating and managing a new international image so that it can maintain a positive USSR presence on the world scene. Moreover, the leadership very likely will reassess the late 20th century political and economic ideological decisions for a quick change to a free-market system. A self-imposed USSR withdrawal from the international scene during this readjustment period very likely would exacerbate a steady decline of its perceived international image or prompt a resurgence of international aggressiveness.

Well within the first decade of the 21st century, all former Soviet Marxist support to governments and factions in the Middle East, Africa, and Latin America will have dried up. There is a likelihood that a small group of former Soviet

Communist Party and military hard-liners within the UIS will offer some support to small nations unable to shake the yoke of the past and turn to democracy. Despite the fading interests in communism, however, chances are good that Chinese hard-liners will attempt the export of Chinese communism at the turn of the century to fill this void in the ideological competition of democracy and communism. Moreover, before 2005, arms sales of late 20th century high-tech conventional weapons in these same regions very likely will be replaced by the sale and transfer of 21st century weaponry. While the USDR and USR recognize a potential threat from China, internal political, social and economic development within these two nations most likely will take priority over any external military investments or ventures.

To be realistic, futurists, planners, policymakers, and decisionmakers, whether they are optimistic or pessimistic about the world's economic, sociopolitical, scientific and technological, and military environments, must recognize that in all likelihood many changes in each of these elements will occur during the next 20 to 30 years. These changes very likely will direct and redirect the destiny of not only the United States, but also every nation of the world and those that have yet to come into existence. Some of these changes have been described in this chapter. Many others that have not been mentioned may, however, occur as a consequence of others that have or have not occurred. Table 11 provides some of the author's insights on some strategic trends and events that have varying chances of occurring. They very likely also will have some degree of influence as to how the world environment of the future, *circa* 2010-2020, might turn out. Although they are not all mentioned or discussed in detail in the text of this study, readers may consider using them as happenings in alternative scenarios for the development of long-range plans, policies, and decisions.

## TRENDS AND EVENTS

ECONOMIC	CHANCES
Competition in world trade	H
Regional economic agreements	H
Economic interdependence	H
U.S. dependence on imports	H
Stability of economic agreements	H
Commercial use of outer space	H
Economic growth for China and the Pacific Rim	H
Multiple-source economic assistance programs	H
Restrictions on trade	H
Near-worldwide free enterprise and markets	H
Economic growth for most nations	H-M
Trade wars and barriers	H-M
Economic growth for the Union of Social Democratic Republics (U.S.D.R.)	H-M
U.S. and U.S.D.R. economic cooperation	H-M
U.S. and Union Sovereign Republics (U.S.R.) economic cooperation	M-H
European free market enters into agreements with China	M-H
Economic growth for the U.S.R.	M
Redistribution of wealth	M
Regional single monetary systems	M
Debt repayments by former Third World nations	M
Cartels control prices and supplies	M
Influence of 20th century international economic organizations	M-L
U.S. and Union of Independent States (U.I.S.) economic cooperation	L-M
Stability of 20th century economic agreements	L
Increase of disparity of economic growth among nations	L

---

Code:	<b>Nominal Term</b>	<b>Probability</b>
	H = High	0.66 and above
	M = Medium	0.65 to 0.34
	L = Low	0.33 and below
	IP = Improbable	less than 0.01

Table 11. The Probable Occurrence of Selected Trends and Events in A New Order of Nations, 2005-2020.



**TRENDS AND EVENTS**

<b>SOCIOPOLITICAL</b>	<b>CHANCES</b>
Diffusion of international power	H
Ad hoc political alliances and agreements	H
Rise of nationalism	H
Cultural values and life-style shifts	H
Worldwide population migrations	H
National pursuit of self-directed destiny	H
U.S. leader of the postindustrial nations	H
Global increase in cultural exchange	H-M
Democratization of governments	H-M
Increase in social investments	H-M
Sociopolitical influence of multinational organizations increases	M-H
Improved human rights and quality-of-life	M-H
Multiple-source sociopolitical assistance programs	M-H
Increase in political freedom worldwide	M-H
European nations move toward a single language	M-H
Increase in global educational and cultural exchange	M
Educational deficit decreasing in industrial nations	M
Cohesion of political alliances and agreements	M
Traditional ideological terrorism decreasing	M
New sophisticated, high-tech international terrorists strike global strategic targets	M
Spread of totalitarian governments	L-M
Cohesion of 20th century political alliances	L
Influence of 20th century international political organizations	L
<b>SCIENCE AND TECHNOLOGY</b>	<b>CHANCES</b>
Global diffusion of science and technology	H
Transfer of technology	H
Increase in scientific dialogue and exchange	H
Diffusion of nuclear power as energy source	H
Increasing research and development investments	H
Regional sharing of nuclear energy	H-M
Potential for nuclear power plant disaster	H-M
Increase in scientific and technological use of space	M-H
Development of alternative energy sources	M-H
Potential for ecological disaster (non-nuclear)	M
Disparity in distribution of technology	L-M

**Table 11. The Probable Occurrence of Selected Trends and Events in A New Order of Nations, 2005-2020 (continued).**

**TRENDS AND EVENTS**

<b>MILITARY</b>	<b>CHANCES</b>
Diffusion of high-tech weapons	H
Ad hoc, short-term defense agreements	H
Arms trade and sales	H
Nuclear weapons accident	H-M
Use of U.S. armed forces for peacekeeping	H-M
Nuclear weapons proliferation	M-H
Cooperative U.S., U.S.D.R., and U.S.R. in prevention of continued nuclear proliferation	M-H
Use of U.S. armed forces for warfighting	M
Utility of military forces	M
U.S. development of new weapons systems	M
Worldwide arms control and disarmament	M
Worldwide propensity for armed conflict	M
Worldwide propensity for low intensity conflict	M
Singular use of a nuclear weapon (nation vs nation)	M
Retention and availability of U.S. basing, port facilities, and overflight rights	M
Stability of bilateral defense agreements	M-L
Worldwide propensity conventional conflict	M-L
Use of military assistance programs	M-L
Projection of military power	M-L
Stability of 20th century collective defense agreements	L
Military use of outer space	L
Weapons in outer space	L
Nuclear conflict (no U.S. involvement)	L
State-sponsored international terrorism	L
Strategic nuclear exchange between the United States and any other nuclear armed nation	L-IP
Total war (global)	IP

Table 11. The Probable Occurrence of Selected Trends and Events in A New Order of Nations, 2005-2020 (concluded).

## **CHAPTER 3**

### **SCENARIO SYNOPSES AND ATTRIBUTES**

#### **INTRODUCTION**

This chapter includes the final bits of germane information about the four scenarios and their construction that will enable long-range planners, policymakers, and decisionmakers to use an alternative scenarios approach more effectively. At the end of the chapter there is a listing of attribute values for each scenario which, although relative, has been derived from each scenario environment. The listing is provided for scenario comparison and analysis.

The first chapter of this study described the general methods used to develop the scenarios. This included a discussion on the *Cone of Plausibility*; the ways to build plausible scenarios; the purpose for the exclusion of wild cards as events or trends and from scenarios; and the reasons for needing scenario drivers to set the theme of each scenario. The second chapter established a common background projection (i.e., a foreground) of the world environment to *circa* 2020 that would be appropriate for creating the four alternative scenarios described in the last four chapters of this study. This chapter describes ways that futurists and planners can develop and complete the scenarios with sufficient detail to give them greater utility. Lastly, included in this chapter are synopses of each of the scenarios and the attribute comparisons that can serve as reference to readers and users for their continued use of these scenarios over time and for different applications.

#### **FINALIZING THE SCENARIOS**

The process used by the futurist to finalize the scenarios uses the *Cone of Plausibility* as do the planners to develop their responses to the scenarios. The process first involves an holistic pondering and reviewing of all aspects of each scenario. It then involves a reevaluation of the logic for and the

derivation of the trends and events within each scenario. The process also includes a reassessment of the interrelated consequences of trends and events by the futurist and the planners together. This can uncover new trends not previously observed. The finalization stage, most importantly, creates for the planners images and visions within the context of the micro-, mini-, and macro-scenarios through a passage of time.

The planners during the process of the Cone of Plausibility give special attention to the interwoven themes within, between, and among the scenarios. Finally, they re-observe the dynamics of cross impacts and changing probabilities of driver trends within the scenarios and the consequences that create the strategic environments of the future.

The finalizing process can be described as follows. The basic drivers or themes for the scenarios are political and economic elements.<sup>1</sup> Using these basic elements and the logic of the Cone of Plausibility, the futurist creates, side by side, a set of four basic driver trend statements in each of four scenarios. They are each a single sentence and as a set they are called a micro-scenario. From this micro-scenario set, planners create the initial organizational planning responses for each of the four sets of future political and economic environments or scenarios. This is a continuous process for the planners, and, in the final analysis, they conclude the planning responses against each of the four scenarios. The purpose of the previous chapter was to broaden the perception of the future for decisionmakers and planners by projecting selected, relevant trends some 20-25 years into the future. This enables readers, planners, and users to envision a common background for creating their scenario responses while the scenarios are further developed and reevaluated here and in the remaining chapters.

In this first step, the planners review and update their responses to the four alternative scenarios in their simplest, but significant, format—the micro-scenarios. All previous planners' responses to the alternative scenarios are now recorded and evaluated as to their fit into an holistic view of or response to each scenario. For this reevaluation by the planners of their first impressions of the four scenarios, the

futurist has rearranged the order of the trends to a theme dominance, i.e., in an order of their dominance of, and influence on, organizational (e.g., U.S. military) plans, policies, and behavior. The reason for changing their order is based on the notion that there are specific trends and events that at any point in time are foremost in creating a society's behavior. They tend to preoccupy the society and, often, become deep-seated for a lengthy period of time. Such trends have a dominant influence on the direction that most other trends and events likely will take in the future. For example, the OPEC oil embargo of 1973 set in motion a dominant trend that indicated a long-term shortage of gasoline. This trend in 1973 was plausible. The long lines at gas station pumps and the daily increase in the cost per gallon made it very real. It altered the direction of most other trends and events, such as noted in the automotive, recreational vehicle, and tourism industries, for the duration of the embargo and beyond for some time. A more recent example, the likes of which have never existed before within this nation, might be the terroristic bombing in February 1993 of the World Trade Center in New York City. This event set in motion dominant trends throughout major U.S. cities affecting long-term security and protection of public and private property, facilities, artifacts, and persons, regardless of the frequency of reoccurrences. One example of possible reoccurrence might be the precautionary measures likely to be taken for any international sporting event sponsored within the United States, such as the 1996 Olympics in Atlanta, Georgia.

When theme dominance is applied to the scenarios at this point of their development, the scenarios begin to show direction and body or substance. The rearranged basic driver-trend statements for the scenarios are displayed in Table 12 (see Table 1 for the transposition). This method of approach to scenario writing assists in maintaining realism and adds variety in long-range planning. For example, in scenario BRAVO the worldwide trend for economic development that strengthens U.S. global influence and preserves U.S. bases overseas is the dominant theme that overrides and permeates all other themes within scenario BRAVO. Whereas, in scenario DELTA that same theme has less probability of influence and

**SCENARIO ALPHA:  
U.S. ISOLATIONIST**

U.S. national political leaders advocate a strong welfare and social investment economy.

Postindustrial infrastructures, along with specialty industries, lack the capacity to support industrial surge requirements adequately.

A rise in nationalism worldwide suppresses U.S. influence and precludes U.S. military presence overseas.

U.S. local community infrastructures<sup>2</sup> inhibit military stationing and reduce installation investment.

**SCENARIO BRAVO:  
U.S. WORLD PEACEKEEPER**

Tradeoffs of nationalism for economic development strengthen U.S. influence and preserve U.S. presence overseas.

Postindustrial infrastructures, along with specialty industries, have the capacity to support industrial surge requirements adequately.

U.S. national political leaders advocate a strong military defense.

U.S. local community infrastructures underpin military stationing and installation investments.

**SCENARIO CHARLIE:  
NEONATIONALISM WORLD**

A rise in worldwide nationalism suppresses U.S. influence and precludes U.S. military presence overseas.

U.S. local community infrastructures inhibit military stationing and reduce installation investment.

U.S. national political leaders advocate a strong military defense.

Postindustrial infrastructures, along with specialty industries, lack the capacity to support industrial surge requirements adequately.

**SCENARIO DELTA:  
MUTED MULTIPOLAR WORLD**

U.S. local community infrastructures inhibit military stationing and reduce installation investments.

U.S. national political leaders advocate a strong welfare and social investment economy.

Postindustrial infrastructures, along with specialty industries, lack the capacity to support industrial surge requirements adequately.

Tradeoffs of nationalism for economic development strengthen U.S. influence and preserve U.S. military presence overseas.

Table 12.  
Scenario Drivers Arranged in Order of Theme Dominance.

the dominant theme is the trend concerning the attitude of the U.S. public toward the U.S. military.

After the dominant and general themes have been established for each of the four micro-scenarios, the scenarios can be expanded outward in time through the holistic logic of the Cone of Plausibility by the futurist. In this process the futurist rewrites each scenario into an expanded theme form called the mini-scenario. Examples of the mini-scenarios are in Appendices A, B, C, and D to this study. These are scenarios of one or two pages in length that now begin to take on identities distinct from one another. The scenarios in this form begin descriptions of logical and plausible futures that might exist toward the year 2020. The planners continue to ponder and reevaluate their responses within the logic of the cone while under the prompting of the futurist to look outward in time. The planners then develop new and additional responses to each scenario based on the broadened information that now appears in each of the mini-scenarios. Considering these new responses, the futurist then writes the final form, the macro-scenario, for each scenario. Additional insights, perceptions, and historical perspectives (from 2000 to 2005 to 2020) can now be provided to the planners by the futurist. This process assures that the futurist is aware of and addresses all of the major related concerns of the planners for the time periods of 2005 and 2020. Planners now, for a last time, review and modify their earlier responses to the scenarios. The macro-scenarios are presented in the next four chapters. The planners' responses are included only in part as examples since they will vary according to the organizational interests of the planning group, e.g., interests may be oriented toward industry, education, or national defense.

## **WORKSHOP RELATIONSHIPS**

The workshop relationships between the futurist and the planners are informal, thereby broadening opportunities for communication. Such exchanges are firm requirements for the development of scenarios. Beyond the scenario workshops, communication can be enhanced by telephonic-computer networking since the planners and futurist are likely to be

remote from each other. The single most important advantage of close and informal workshop relationships is that the futurist can envision and design the scenarios with first-hand knowledge of the planners' insights, concerns, and problems related to scenario responses. At the same, the futurist can describe trend and event consequences and their future implications that are most likely to challenge the skills of the planners and policymakers.<sup>3</sup> In those cases where planners or policymakers design the scenarios instead of futurists, the environments are often written so that they accommodate planning and policy goals, i.e., they are skewed, biased, or parochial. The single most important responsibility of the futurist is to maintain the integrity of the scenarios once they are completed for the planners' final analysis and responses.

Upon completion of the above steps, the final scenarios, prepared by the futurist, and the final responses, provided by the planners, are addressed once again in a final workshop. Each macro-scenario can be assessed by the futurist with the planners for plausibility, logic, and fit. Assessment criteria are based on the resource constraints posed by the economic and political environments that are embodied as variables in each respective scenario. A synopsis of each of the final four scenarios of this futures study is presented below. Each synopsis includes the futurist's forecasts of the scenario drivers and the futurist's and planners' notional responses<sup>4</sup> to each scenario environment.

## **SYNOPSIS OF THE SCENARIOS IN 2020**

Some of the differences between the scenarios are readily apparent by their titles alone. Additional significant differences are evident within each scenario as a reader peruses or a planner analyzes its contextual substance. Unless a scenario is written in great detail, many implicit, cause and effect, or consequential trends can develop and events occur that fall within the narrative of the scenarios. The following synopses are summarized here to aid those who will use the scenarios for planning or policymaking purposes. For each of the scenarios the synopses are broadened to include some of the



inferential consequences that are built into the scenarios. The synopses are set in the context of the year, *circa* 2020.

**Scenario ALPHA: U.S. Isolationist.**

Scenario ALPHA describes a relatively peaceful world where the U.S. perception of an external threat is low and the size of its military force is small. The U.S. leadership and its business infrastructure in this international environment have turned toward isolationism. In general, the concerns of the U.S. leadership and its citizens in the year 2020 are directed more toward greater budgetary investments in social, welfare, educational, and environmental programs than in programs for space, defense or foreign economic and military aid. For the most part, the infrastructures of the United States and the other postindustrial nations individually do not appear to have a capacity to support a timely major military or industrial surge in the event of national or global crises.

A rise of nationalism throughout many nations of the world, including nations with prior long-term agreements with the United States, has suppressed U.S. international influence and has precluded U.S. military presence overseas. Increasingly, on the home front, despite the small number of military forces, local U.S. community infrastructures (economies, politics, resources, and demographics) are inhibiting military stationing and training requirements, as well as other installation activities. Public indifference to new military investments (especially those related to weapons and their movement into or out of stations and through community thoroughfares for testing and training) has generally hampered any semblance of military preparedness.

The U.S. defense budget has plummeted significantly since the turn of the century. The pressures of congressional environmentalists have forced the closure of many of the remaining military bases that were not closed around 2005. The U.S. armed services have been reorganized into a joint/unified configuration called the General Defense Forces (GDF). New military and other government personnel are acquired through PEP, a nationwide Public Education

**Program. Slightly more than about half of the total U.S. military force is equipped with high-tech, state-of-the-art, 21st century equipment and weapons. The warfighting GDF, Land Defense Forces (LDF), Sea Defense Forces (SDF), and Air and Space Defense Forces (ASDF), overall, are 15 percent heavy (not easily deployed), 50 percent medium, and 35 percent light (easily deployed). Most SDF ships (U.S. Navy) have been mothballed, since they are outmoded and of mid 20th century vintage. The remainder are high-tech and staffed by well-trained career SDF personnel. The ASDF (Air Force), although reduced in personnel strength, has sufficient highly-trained warfighter personnel to support its high-tech contingency air and space craft, weapons, and other equipment. Older 20th century aircraft have been scrapped or converted to civilian use.**

**Despite a mild U.S. economic slump and a global recessive trend, the world's economy continues to experience fluctuating periods of high and medium growth, yet is invigorated and remains highly competitive. The European Community, essentially a singular unit, has abandoned defense expenditures to meet the heightened demands of economic competition from the Asian-Pacific Rim markets. The Union of Social Democratic Republics (USDR), a new confederacy made up of and derived from several former Soviet Union republics around the turn of the century, has progressed sufficiently well in economic, political, and social development to be accepted (marginally) as a postindustrial nation by other nations in that category. The USDR is highly competitive with the Union of Sovereign Republics (USR), another confederacy of former Soviet Union republics, but retains certain grievances against the USR. The USDR and USR, however, maintain close, supportive relationships through a temporary Commonwealth of Confederacies which replaced a previous commonwealth over a decade ago. Both the USDR and the USR have small, well-structured armies and both possess nuclear weapons.**

### **Scenario BRAVO: U.S. World Peacekeeper.**

Scenario BRAVO describes a competitive world of economic trade markets where an undercurrent of external threats and contentions, both economic and military, to U.S. interests are perceptibly increasing. Worldwide, U.S. economic and military assistance agreements are many and backed by a large U.S. peacekeeping military force. A tradeoff of nationalism for economic development and representative government by many nations worldwide has strengthened U.S. international influence, preserved U.S. investments, and assured the United States of a military presence overseas. The presence of U.S. industries, with their advanced facilities and know-how, is visible and productive in most nations of the world. Deindustrialization of the United States and most of the other postindustrial nations has occurred since the latter half of the past century. Almost all of these nations by 2010, however, can still support an industrial mobilization or even surge requirements quite well in the event of confrontations or global crises.

Over the past decade or so, the leadership in the U.S. Congresses and the Administrations have advocated a strong military defense. Sizeable and costly military exercises are being conducted worldwide. U.S. military forces are freely participating in combined land exercises in many regions of the globe where the U.S. military have never been seen before, e.g., in land masses of Asia, China, and, as early as 2000, in the former 20th century Soviet Republic of Russia. Russia is the leader of the confederacy of the Union of Sovereign Republics (USR).

Throughout the continental United States, nearly all local communities have accepted military service men and women as part of the community family. Defense budgets are strongly supported by the American public, as are budgets for welfare, education, and the environment. The leadership and citizens of most U.S. local communities underpin and encourage military stationing and installation investments in their neighborhoods without conditions. They also share with the U.S. military service men and women the personal and

community enrichment brought about by an ever increasing foreign military personnel exchange program. Such enrichment is further increased through the international scientific and cultural exchanges that are evident in the BRAVO world of 2020.

In BRAVO, the U.S. military budget has increased substantially since the turn of the century. This has come about since 2005 when a more aggressive USR leadership reinforced its military forces because of internal, ethnic strife and perceived external threats. By 2005 the USR's conventional strength, its residual nuclear capabilities, and its achievements in space (alone and jointly with the United States), have become potentially formidable threats to the Union of Social Democratic Republics (USDR), the European Community (EC), United States, possibly China, and other nations. The USDR, a marginal postindustrial nation contiguous with the USR, has increased its military forces also. These potential threats have pressured the U.S. Congress, around 2005, to enact an 18-month National Public Service (NPS) program that includes all agencies of the federal government and provides training for all citizen and noncitizen residents. For the military services, which had been all volunteer, NPS provides a constant source of trained troops. The U.S. military leadership believes its total force is well prepared for any eventuality. The total force is 60 percent high-tech while the warfighting force is 85 percent high-tech. The active U.S. military strength in personnel is about half that of an over-a-million Reserve Component.

#### **Scenario CHARLIE: Neonationalism World.**

The rise of nationalism worldwide in scenario CHARLIE has significantly suppressed U.S. political, economic, and military influence and has eliminated the presence of the U.S. military forces and most American industries overseas. CHARLIE is a highly competitive world where economic trade wars, embargoes, and restrictions abound. The European Community (EC) is experiencing an economic pinch of the nationalistic, worldwide fervor for nations to buy at home. Since around 2005, the EC has perceived no significant military

threats to itself, its interests, or to the rest of Europe. With the exception of France and the United Kingdom, all other EC states have demilitarized. NATO became an empty shell nearly a decade ago. The EC and NATO, except for one or two states, essentially, would be unable even to support a peacekeeping force effectively, alone or within a United Nations force, or to quell ethnic conflicts in the EC or in neighboring states. By 2005, nearly all U.S. forces have left Europe except for a few over-manned caretaker contingents and the U.S. forces involved in training exercises in the Union of Sovereign Republics (USR) and the Union of Social Democratic Republics (USDR).

External threats to the United States or its interests are more of a challenge to U.S. economic trade and markets than they are threats to political ideology that would call for the use of military force. Largely for this reason, the U.S. leadership has provided substantial budgetary support to social and welfare programs and far less to defense. The military budget remains low despite U.S. national political and military leaders advocating a need for a stronger military. This has constrained U.S. security to a small, high-tech, elite military force and has reduced the Defense budget to its lowest level since the 1930s. A significant portion of the Defense budget is invested into high-tech weaponry and its ancillary equipment, and research and development, in general. The general public opinion of military service is high. However, partly because of population growth and partly because of military environmental infractions, local U.S. communities do not want military installations in their back yards. These communities tend to block military stationing requirements and are demanding that Congress close more stations and reduce military installation investments. The congressional majority also perceives little or no significant threat or a need for a large military establishment, and supports the interests of these communities. Since the military needs only to staff a small force, its source of physically, mentally, and morally fit volunteers for career service is provided through the Universal Public Service (UPS) program of 2003.

Since the late 1990s and the early 2000s, the continued U.S. economic support to Russia and Ukraine (especially), Georgia, and other republics of the former Soviet Union has given these new nations status in the new order of nations. Russia, *circa* 2005, formed a new confederacy with several other former republics and has become the leading republic of the Union of Sovereign Republics (USR). Likewise, Ukraine has become the leading republic of the Union of Social Democratic Republics (USDR). Drawbacks in the USR by 2010, such as mismanagement of the national economy and sociopolitical struggles, including ethnic strife, have prevented the USR from achieving the status of a postindustrial state. It remains an industrial country, whereas the USDR held steadfast to democratic government reforms and wisely managed its economic affairs. Additionally, the USDR skillfully averted the ethnic fighting that largely sapped the progress of its neighbor confederacy, the USR. For these reasons, the USDR has been marginally accepted by the other postindustrial states to join them in the management of peaceful world affairs. Both the USDR and the USR have modern military forces and both have nuclear weapons.

The elite military forces of the United States are organized as the National Defense Force (NDF) and include all services. The NDF is fully capable of land, sea, air, and space operations. It is operationally situation-dependent, i.e., organized for warfighting in any one of the four operations alone, in dual combinations, e.g., air or space and land or sea, or in a multi-operational configuration, all four at one time. The NDF is supported by a large single reserve component (National Guard and Reserve combined). Both the active and reserve components are 100 percent high-tech equipped and trained. Operational doctrine and warfighting strategies are highly advanced to match the capabilities of the elite forces, i.e., any combination of strategies and operations.

#### **Scenario DELTA: Muted Multipolar World.**

This scenario describes a productive economic world where U.S. political leadership favors social and welfare investments over those of defense. DELTA, however, is a

scenario where U.S. local communities increasingly object to military activities at installations in or nearby their communities. The worldwide threat to the United States and its interests is generally perceived by the U.S. leadership to be about the same as it was in the late 1990s, i.e., more of an economic threat than a military one and with a constant global demand to prove its global leadership. Since the turn of the century and by 2020, the military threat emanating from the Union of Sovereign Republics (USR) has steadily grown. The USR is a new confederacy made up of several republics of the former Soviet Union, largely Russia, in about 2003. In 2020 the USR is under a coalition leadership that is an economically aggressive three-party system: democratic, communist, and socialist. The military threat is greater for the European Community (EC) and the other confederacies formed from the former Soviet Union republics in the first decade of the century than it is for the United States. The other confederacies are the Union of Social Democratic Republics (USDR) and the Union of Independent States (UIS). The EC, driven by its need for new global economic markets, by 2005 is gaining in economic growth while gradually improving its competitive position globally, especially in the Asian-Pacific Rim markets. U.S. international economic and political influence, during the same time, is being strengthened worldwide by most nations that are making a tradeoff of nationalism for economic growth and are encouraging U.S. trade and tourism.

The reduction of the U.S. military during the past several decades has decreased U.S. presence overseas and reduced the number of local military installations throughout the United States. About 2005, the President combined the Army, Navy, and Air Force into one joint service, primarily to reduce costs and redundancies. The President and the Congress believe that the single joint service will be more responsive to global crises than the services would be separately. They also believe that a jointly responsible service will be better able to accommodate state and local governments and their citizens who are demanding greater military adherence to Federal laws regarding the protection of the environment. Local and military community relationships have been faltering in the DELTA scenario almost since the turn of the century because of the

military's disregard of the environment and its procrastination in clean up of its past violations.

Since the turn of the century the Defense budgets and related programs have been increasingly austere in comparison to past funding of the military in the late 20th century. The national economic benefits of military assistance programs in the DELTA world, however, are mutually satisfying to host nations and to the United States. These arrangements, i.e., overseas assignments for active and reserve forces, although limited in number, along with other inducements support voluntary military enlistment as the only source of recruitment for the joint service in the DELTA scenario.

The DELTA 2020 military force, organized as a single, Unified Defense Force (UDF), is a mix of generalists and specialists. The UDF has light (easily deployable) high-tech land, air, and sea components for rapid shock attack. They complement medium and heavy (less deployable) land, air, and sea components that have high-tech, light weight, high resistance armament and 21st century weaponry; some are remotely controlled robots. The UDF is supported by a component of National Guardsmen and Reservists who wear the UDF uniform when in active service. The primary role of the DELTA 2020 military force is defensive, but it is fully capable of responding to a variety of offensive missions and situations when needed.

## **ATTRIBUTES OF THE SCENARIOS IN 2020**

When a scenario is in final form, various conditions and attitudes are created. They reflect the intensity and direction of the scenario drivers, express the overall character of composition of the scenario, and vary from one scenario to another. These are scenario attributes that can be observed or assumed to exist in the scenario environments. They are variables that depend on the scenario drivers and, where possible to quantify, can be expressed as a numerical range. These attributes are important to the reader and user of the scenarios since they aid in the understanding of the scenarios. Where the scenarios bear close similarity in design and



content, as is the case of the scenarios of this report, the attributes can be compared from one scenario to the next. Table 13, which displays the attributes that are shared by the alternative world environments of this report, includes a suggested baseline value, and a relative value for comparison of the scenarios in the end year of 2020.<sup>5</sup> Using these suggested data, planners can structure intermediate scenario snapshots consistent with the basic scenarios and the attributes which will vary from one time increment to the next.

<b>SCENARIO ATTRIBUTE</b>	<b>BASELINE*</b>	<b>ALPHA</b>	<b>BRAVO</b>	<b>CHARLIE</b>	<b>DELTA</b>
Global economy (Growth 2% - 5%)	4%	2%	4.5%	4%	2.5%
Global nationalism	M	H	L	H	L
U.S. global military deployment (Forces deployed 0-500K)	500K	0-50	500	105-200	250-300
U.S. economy (Growth 1.5-3%)	3%	1.5-2%	2.5-3%	2-2.5%	2-2.5%
U.S. trade dependence (10-20% of GNP)	12%	10-15%	15-20%	10%	15%
U.S./Allied relationships (Poor to Good)	G	P	G	P	G
U.S. Army overseas (0-300K)	250K	0-10	300	10-25	150-200
U.S. local acceptance of military bases	H	L	M-H	L	L
U.S. public image of military service	H	L	H	H	M
U.S. defense spending (5-10% of GNP)	6.5%	5%	9-10%	7-8%	6%
USDR economic growth	4%	2-4%	3-5%	3-4%	2-4%
USR economic growth (2-6%)	4%	1-3%	2-4%	2-5%	2-4%
USDR military growth	2%	1-2%	3-4%	2-3%	2-3%
USR military growth (1-4%)	2%	1-3%	3-4%	2-3%	2-3%
U.S. perceptions of security threat	M	L	H	L-M	L-M
European Community perceptions of threat	L-M	L	H	L	M
Nuclear weapons proliferation (9-24 nations)	M-L	H	L	M	L

\*Key to ranges: H = high, M = medium, L = low, G = good, P = poor.

Table 13. Comparison of Scenario Attributes for 2020.

## **CHAPTER 4**

### **THE ALPHA SCENARIOS: U.S. ISOLATIONIST**

#### **ALPHA 2005**

The United States by the year 2005 continues to evolve as one of the foremost postindustrial nations of the world. Since the early 1990s, the U.S. leadership (both the Administration and the Congress), by popular demand and championed by a politically active and powerful aging population, has sponsored and achieved increasingly more social and welfare oriented domestic programs than programs related to national defense or foreign military aid. In addition, programs budgeted for environmental protection, education, and space exploration have gradually surpassed those for defense programs, which are followed in their turn by lower budgets for science and technology.

Throughout the United States over the past decade or so, the distribution of Federal funds has resulted in an increase in federal, state, and local environmental protection legislation and regulations. Despite the Department of Defense position that these regulations are encroaching upon military installations, the growing political influence of environmentalists has forced the closure of a number of military installations. The land has been turned back to the states for state and local use. This currently popular attitude is not an expression of an antimilitary sentiment; it does, however, support a growing public belief that most military activities belong in low-density population areas. A contributing factor to these attitudes has been the overcrowding of military bases by forces returning from overseas bases. Because of the reduced stationing facilities in the states, 30-40 percent of returning units have been assigned to the Reserves or

deactivated, while troops have accepted Reserve assignments or mandatory retirement.

Another factor contributing to the public attitude, which has lessened most communities' need for financial support from military installations, has been a gradual rising of national economic growth and employment rate (unemployment is down). Moreover, problems for military installations are exacerbated further by the growing U.S. population with its need for living space and by the increasing number of light specialty and high-tech industries with their need for industrial parks. Either or both of these have surrounded and, in some instances, encroached upon military installations. Increasingly since the late 1990s, the abundance of job opportunities available in the high-tech postindustrial U.S. society has resulted in a general nationwide attitude of disinterest in the military and a greater interest and awareness in community development by federal and state governments as well as by the general public.

The Congress, in order to accommodate the growing need for all citizens to be trained and to develop new skills for the U.S. postindustrial society, passed in the year 2005, a federally subsidized, 18-month public educational program (PEP) that is now completely operational. PEP encourages all interested citizens and residents over 19 years of age without regard to race, creed, sex, disability or other orientation, to enroll for the full program with an option for outstanding trainees on completion to continue careers in public service in the various federal, state, or local governments. Competition by the various federal departments for high-quality PEP trainees is quite keen. The Defense Department, within this competition, is faced with an increasingly difficult task of acquiring the caliber of volunteers it needs for its specialized military programs.

Increasingly, over the past decade, the industrial base of a number of newly industrializing countries (NIC) has been expanding. This largely has been the result of a relocation of many heavy industries. These industries have been chemicals, steel and iron, automobile production, arms manufacturing, and building and construction supply businesses from the

United States and other Western nations primarily, as well as from Japan and some of the East European nations. The new industrial base of the NIC is increasing employment, raising the overall standard of living and providing encouraging economic growth, while it also is creating an increasingly competitive world economy. Many of the NIC are in various stages of perfecting free-market economies and democratic societies. For others, the transition from centrally controlled to free societies has been made easier by the leadership and management of relocating foreign industries. Concerned with the need to protect their interests, many of the NIC have been armed with late, mostly conventional, 20th century weapons by the arms merchants during that era. Others now are buying new and affordable high-tech weapons systems from the new 21st century arms merchants. A few, openly or secretly, are investing also in nuclear weapons and delivery systems as well as chemical and biological weapons to build or increase their arsenals.

The combined effect of new found economic status (i.e., from Third World nations to modern, newly industrial nations) and political power has encouraged a rise in nationalism and independence within many of these countries. This transition is accompanied by a cultural strangeness of and unfamiliarity with new industrial technology and the political/economic power of a free-market economy. While most of the NIC are currently considering nationalizing foreign industries, others not only have already done so, but, selectively, they have also ousted many foreign technicians. Moreover, some of these same countries have requested that foreign nations close their military bases, while others, despite long-term political and military agreements, have been more aggressive. These countries have denied overflight and port visitation rights and have reclaimed the lands of foreign military bases located on their territories. As a final action, they have demanded remedy for environmental damage to their countries.

The postindustrial nations, faced with a declining industrial infrastructure, especially in heavy industry during the past several decades, still retain a residual industrial capability. Some of these nations (including the United States), however,

are concerned currently that, if this industrial decline continues, they likely will lose the capacity to support national industrial surge requirements should war occur. Subsequent to the breakup of the Soviet Union in the early 1990s, the European Community (EC) increasingly had become disillusioned by the apparent U.S. turn toward isolationism and the reduced U.S. economic aid to the former Soviet Union republics. As a result, most of the EC nations, rather than to return to strengthening their own war-fighting capabilities that were previously provided by the presence of U.S. forces during most of the 20th century, have been encouraging East European participation in the EC. Also contributing during the 1990s to the EC decision to include these nations were the following situations: 1) the waning of U.S. interests in and commitments to NATO; 2) the U.S./Russia mutual force reductions in Europe in the early 1990s (90 percent of all overseas U.S. forces have returned to the United States; all former Soviet forces have returned to the Republics); 3) the gradual nuclear weapons reductions between the United States and Russia (which began initially in the late 1980s with the former Soviet Union); and 4) the increasing world economic and trade competition. The EC logic is that including these nations would build their economies, gainfully employ more people, very likely reduce ethnic conflicts, and create new opportunities for the EC in the global market.

Russia, the largest and most powerful country and preeminent force emerging from the former Soviet Union and its temporary successor, the Commonwealth of Independent States (CIS), has formed new economic alignments with other former Soviet republics. The Republic of Ukraine, likewise for economic advantages, has formed the beginnings of a new confederacy. Both have been increasing their efforts to improve their internal economic development and place in the world's free market through these new cooperative agreements with the other like-minded republics. Despite the breakup of the Soviet Union, the subsequent emphasis on economic stability, and the move to reduce arms, Russia, Ukraine, and the other former Soviet republics retain formidable military power. They have, however, more aging and obsolescent weapons than new 21st century systems.

Since East and West Germany united and the Warsaw Pact was dissolved in the early 1990s and the former Soviet forces have been withdrawn from their countries, a significant military strength in the former Pact member states no longer exists. The interests of the former Pact countries are now in pursuing economic development and in the building of free states.

The CIS and East European economies increasingly are bolstered by growing economic ties with the EC and the Asian-Pacific states. U.S. economic aid and other assistance to the former Soviet republics have been reduced dramatically or discontinued. By 2005 Russia and Ukraine, each with their alignments of other former Soviet republics, are becoming more economically than militarily adventuresome and unpredictable. Increasingly, former Soviet republics with like or common interests are grouping together economically and politically to form new confederacies under a new administrative commonwealth that is not unlike the CIS. The CIS was created in 1991 and became a provisional, administrative body to assist in the control and disarmament of nuclear weapons and to give some structure to the dismantling of centrally controlled government and the transition to free, representative government.

In an effort to maintain international prestige and visibility on a global scale, Russia is continuing with space programs planned by the former Soviet Union. The Russian space ventures—more numerous than those of the United States, Japan, or the European Community since the successful joint U.S./Russia Mars landing—offer more favorable world publicity than an adventurous military undertaking. The ousting of U.S. military forces from some of the NIC, however, has encouraged the Russian leadership to seek economic, political, and military ties with those countries. The NIC, however, are no more interested in a Russian presence, the presence of other former Soviet republics, or of any foreign element in their country than they were in that of the United States.

The combined impact of world and domestic events by 2005 increasingly is thrusting the U.S. defense strategy toward isolationism and is returning the United States and Russia,

again toward reliance on a strategic nuclear deterrent. All of the U.S. services have faced force reductions including shrinkage of installation accommodations. The U.S. Navy (surface, subsurface, and air) is becoming the bulwark of the U.S. continental defense. Air Force budgetary and personnel reductions along with installation closures have resulted in the Air Force being restructured and reduced in size, leaving its bomber force of aging aircraft retaining a strategic, albeit deteriorating, capability. Its strength, however, remains in its strategic warning and space surveillance capabilities and its limited strategic defense systems in space.

Subsequent to the overseas force withdrawals, troop and budgetary reductions, and installation closures of the 1990s, the military is being challenged increasingly now with the problems of mission management, identity, and retention of an adequate defense posture. To meet this changing, relative peacetime world the U.S. armed services are reorganizing into a joint/unified configuration, called the General Defense Force (GDF). It is comprised of the Land Defense Forces (LDF), the Sea Defense Forces (SDF), and the Air and Space Defense Forces (ASDF). The GDF in 2005 has been organized into regional commands.

The Land Defense Forces (LDF) include the Active, Reserve, and civilian components of the Army. The total force is about 50 percent light (rapidly deployable); the Reserve component is about 75 percent heavy (not readily deployable). The active Alpha 2005 LDF are comprised of about 500 thousand troops whose capabilities are oriented toward low-intensity conflict, with almost all units assigned to unified commands. They are supported by a Reserve component which includes both Reserve and National Guard, of about 950 thousand troops and by a civilian component of about 300 thousand trained personnel. Equipment for the Active and Reserve component of the LDF in 2005 is about equally distributed in 21st century high-tech equipment, 1990s vintage equipment, and older equipment of 1980s vintage that is obsolescent. The deployment of the LDF in 2005 heavily depends on civilian facilities for air and seaports of embarkation. The ALPHA 2005 GDF, i.e., all of the services,



for the most part, uses home-station training with computers and, at the nearest work station, conducts exercises with simulation devices. Unit training for the GDF is by simulation conducted at regionally leased training centers that use about 80 percent contractors as trainers. Installations, where possible, have multipurpose use and are about 80 percent contractor operated. Increasing social investment policies of the Federal Government provide a quality of life to the GDF which is comparable to that of the general society. Sustainment of the GDF in 2005, however, is considerably reduced because of these same social investment policies. Similar descriptions can be made of the other reorganized joint/unified services, the Sea Defense Forces (SDF) and the Air and Space Defense Forces (ASDF).

## **ALPHA 2020**

In the year 2020, the United States, internationally, is recognized as the foremost economic postindustrial country of the world. It is faced, however, as it enters the year 2020, with a mild economic slump, well short of a full recession, where the general economy is slightly declining and operating partially below capacity. Increasingly over the past decades the U.S. political leadership—the Administration and the Congress—has expanded federal support to improve social welfare programs. Moreover, the leadership in 2020 is so supportive of these social programs that the United States is skewed decidedly toward a social investment economy. Budgetary support of social programs (which are over 70 percent of the national budget) is followed by national public education, environmental protection, space, defense, and science/technology programs. Defense programs have dropped to an all-time low. Most national strategists believe that this obsessive national trend in social investments by the U.S. leadership demonstrates a serious neglect of the other programs of the nation, especially those involved with national security. The same trend, however, has been occurring in most of the other free-world nations as well.

By the year 2020, the growth of the U.S. population (more than 300 million) in general as well as in and around U.S. cities

(more than 85 percent of the U.S. population are urban dwellers), especially those cities contiguous to or within a 50 mile radius of military bases and installations, has complicated the stationing and activities of U.S. forces. Training and testing facilities and weapons ranges, which retain 20th century configuration, are affected most. Throughout the states since the turn of the century, the military services have been unable to cope with environmental issues of pollution and resources conservation (especially water) associated with military activities. Additionally, such demographic factors as an older, more conservative electorate along with an ethnic distribution that is approaching half black, Hispanic, and Asian have brought about a general change of attitude toward war and international involvement that rejects both. Increasing affluence and leisure time of the average American worker also have brought about activities that are preventing military stationing in close proximity to high density population areas. The additional U.S. communities that have achieved economic self-sufficiency since 2005, collectively, continue to inhibit military stationing and reduce installation investments through lobbies for state and federal legislation or by outright political activism and demonstrations.

During the past several decades, most of the nations of the world have experienced a period of rising economic growth that has been increasingly challenged by an invigorated, but highly competitive, world economy. In 2020, however, economic indicators are showing a global recessive trend. Concerned over their national economic interest, 60 percent of the nations of the world (based on 168 nations), except the very poorest, are armed with early 21st century conventional weapons; 20 percent are also armed with the latest high-tech weapons and systems, and over 14 percent have nuclear weapons and delivery systems in their arsenals.

Most of the heavy industries, those that made nations great during the past two centuries, essentially have disappeared from the postindustrial states of the United States, Canada, Europe, Australia, and Japan. They have been relocated in the industrial states in South, Southeast, and Southwest Asia; China; South America; and the USSR. Most industries remaining

in the postindustrial nations are high-tech oriented and are supported by an increasing number of light, specialty industries. The heavy industrial needs of these nations are imported competitively in the world market. This situation has brought to the forefront the realization that the postindustrial infrastructures in the year 2020 lack the industrial surge capacity to support national mobilization plans.

The new international economic status and the regional positions of prestige and power that began early in the century for the industrial states (some of which were formerly Third World nations) continue to nurture a general rise of nationalism worldwide. This has affected U.S. international political influence adversely and has resulted in the expulsion of all U.S. forces from U.S. overseas bases and port facilities, and in a repossession of the land, regardless of prior agreements with the United States. Most forces that have returned from overseas have been retired or have been assigned to the Reserve component and their units deactivated. World conditions in 2020 make U.S. reliance on nuclear deterrence more critical than it was at the turn of the century. The deployment of a limited U.S. strategic missile defense system in space, however, contributes heavily toward the U.S. deterrent posture.

The economic progress that almost all nations have made, along with absence of any major wars over the past 30 years or so, have outbalanced an armed and militarily competitive world in furtherance of a peaceful but highly economically competitive world. The United States, despite a current, although near-predictable cyclic mild economic slump, remains a prospering postindustrial state. The new Russian confederacy, the Union of Sovereign Republics (USR) is an industrial state striving to increase its internal economic and social development programs that began with the former Soviet Union in the late 1980s. The international trade and economic investment activities of the new Ukrainian confederacy, the Union of Social Democratic Republics (USDR), is a postindustrial state. Since the 1990s both states have become increasingly capitalistic and adventuresome in the world's markets. An undercurrent of traditional Soviet

communism, however, remains intact in the USSR and the USDR, especially in the USSR. The USSR also has been burdened with ethnic strife since the turn of the century. The status of USSR military power, notwithstanding, by 2020 has become increasingly more defensive than offensive and the export of ideology is tied more to client-state economic programs than to military programs or political ideology. Moreover, internal economic growth, the building of more space platforms, and a limited, strategic missile defense system in space, as well as the expansion of its manned Mars station have taken precedence over maintaining a large and expensive military force. The USSR, nevertheless, still remains a substantial military power in 2020, as does the USDR, when compared to other nations.

The reorganization of the U.S. armed forces, completed in 2005, that formed a peacetime joint/unified force, the General Defense Force (GDF), remains adequate for most contingencies within a one-war strategy. In general, U.S. forces are stationed in available existing installations that are in low-density population areas of the United States and that are shared with other federal agencies. The role of Land Defense Forces (LDF) in 2020 is mainly defensive and complements nuclear deterrence. The Active Army is comprised of a small (250 to 450 thousand troops), volunteer, high-tech, multi-mission, rapidly deployable Professional Defensive Force (PDF) organized in light units. Most volunteers come from the Public Education Program (PEP) created by the Congress in 2005. This force is supported by a larger (700 to 800 thousand troops) single Reserve component of the LDF. The active and reserve forces are supported by highly trained LDF civilian component (200 to 250 thousand personnel). In general, the quality of life for the PDF and LDF in 2020 matches the civilian sector in all respects.

Force structure for the GDF is designed to accommodate a unified, joint force for warfighting needs. The Active PDF (Army) component is structured in combat, combat support, and combat service support-like units. The total force of the GDF includes about 15 percent heavy (not easily deployed), 35 percent light (rapidly deployed), and 50 percent medium

combat forces. A fifth of the total force is vehicularized land and air units. The LDF Reserve component is structured in four regional commands located in the United States, each with a specific defense mission, but is considerably less deployable than the PDF. The equipment used by the PDF and the Reserve is about half late 20th century and half early 21st century. About one third of the Reserve component is considered ready. Deployment of forces primarily depends on post-event, ad hoc alliances with allies providing a major share of land forces. In the event of a conflict, mobile operational bases (sea and air) are of utmost importance for the PDF. The GDF, in 2020, are making greater use of robotics as well as intelligence and antiweapons provided by advanced space technology. Additionally, the PDF by 2020 is using home-station training, existing and available regional training centers, and leased areas of land for mission training purposes. Operational training for combat is accomplished through the use of variable computerized simulations (e.g., virtual reality) and simulators, which are especially important for training with advanced weapons systems that have near infinite ranges.

Advocates of a strong U.S. defense are faced with a postindustrial infrastructure that lacks the capacity to support mobilization plans. They are confronted also with loss of defense facilities throughout most of the states. Moreover, they are opposed by local communities throughout the nation. These communities are inhibiting military stationing and forcing the Congress to make more reductions in military installations. Moreover, behind the apparently peaceful economically competitive but viable world in 2020, a latent threat to world peace and U.S. interests exists, especially if nations resort to the use of military actions rather than the use of economic strategies.

## **CHAPTER 5**

### **THE BRAVO SCENARIOS: U.S. WORLD PEACEKEEPER**

#### **BRAVO 2005**

Over the past decade most of the nations of the world, especially the newly industrial countries (NIC), formerly the Third World, increasingly have encouraged the presence of the United States. This infusion of U.S. industries, businesses, and its military has nurtured new economic growth in the NIC along with an orderly transition of many of these nations to modern industrial statehood. Through its good offices, economic aid, and industrial leadership, the United States is raising the national pride of these nations while protecting and furthering U.S. base and overflight rights. Several of the agreements (e.g., Malaysia, Mexico, the Philippines) formed since the start of the century have been less formal than the 20th century treaties and agreements.

During the past 20 years or so most of the postindustrial nations (Australia, Canada, Europe, Japan, and the United States) increasingly have experienced deindustrialization. Heavy industries such as steel, chemical, arms manufacturers, and construction materials, as well as other types of manufacturing businesses have relocated to foreign countries, e.g., Korea, Taiwan, Malaysia, the Philippines, Mexico, Venezuela. A few of these countries have relocated industries also. Although within the postindustrial nations high-tech and specialty industries with new products are creating substitute products, sufficient industrial capacity remains in the postindustrial nations to support surge requirements, should war appear imminent. The industrial sectors of the postindustrial nations are well advanced technologically, especially those of the United States.

The high-tech specialization in the United States is creating new and innovative products that are robotic and plastic or the results of genetic engineering. All are improving the overall national economic scene as well as the quality of life of the general public. Further, these new industries increasingly are creating opportunities for additional new industries and employment. Since the mid-1990s, U.S. public education, under federal guidelines, has instituted new programs to accommodate the rapidly changing postindustrial U.S. society. Along with many new advanced courses related to high technology, there are courses in speed-learning of foreign languages and cultures designed to prepare graduates for both government and private employment. In 2005, as many as a third of the employees of most major U.S. industries work for their companies overseas for extended periods of time.

In general, since the late 1990s the political attitude of both the U.S. Congress and Administration has favored larger defense budgets. Over the same period, federal expenditures have also increased for space research and exploration as well as for science, technology, and education, respectively. Social programs continue to be the highest budgeted item; such expenditures, however, have been on a gradual decline since mid-1990. By 2005, the United States has substantially increased its foreign aid programs and has been especially generous in economic aid to former Third World countries (mostly newly industrializing nations [NIC]) striving to develop the skills needed to achieve success in industrial statehood. Additional U.S. dollars going to the NIC are for military assistance programs, most of which emphasize defensive military training using largely 20th century arms and early 21st century high-tech systems.

By the year 2005, many nations of the world, including the newly industrialized nations, have achieved a new economic prosperity. This growing affluence is commensurate with general increases in their industrial productivity and trade. Some of these nations, however, harbor real or perceived fears of their economic competitors and remain heavily armed with conventional weapons purchased from the arms dealers of the 20th century. Others continue to build their weapons

inventories with early 21st century high-tech weapons purchases. Some of the NIC are producing light arms and ammunition, while others are developing high-tech weapons industries under co-production arrangements with some of the advanced industrial and postindustrial nations.

Russia and other countries that emerged from the former Soviet Union of the 20th century became nations of the Commonwealth of Independent States (CIS) in the 1990s. The CIS was formed to accommodate the transition from a centrally controlled government and economy to democracy and a free market system. The CIS served more as an administrative body than a governing one and was only loosely associated with its member states. The new states continued their efforts toward internal economic development using programs that they began in the 1990s. At the same time, some of the new states have been able to generate a modest level of military expenditures. They can easily purchase arms from available foreign dealers or confiscate weapons from the disarrayed army of the former Soviet Union. Although none of these states are considered a military threat to the United States, collectively they cause some concern to the nations of Europe. Russia has maintained moderately high expenditures in weapons programs, especially those related to military space activities. The conventional threat once posed by the former Soviet Union and the Warsaw Pact no longer exists.

Since the early 1990s and stemming initially from U.S./Soviet arms control meetings in the late 1980s, then from U.S./Russian meetings in the 1990s, Russia and the United States have made dramatic progress in the bilateral reduction of nuclear weapons. Accounting, however, for all nuclear weapons possessed by the former Soviet Union and that once confronted Western Europe is an unverifiable task. Proliferation of nuclear weapons, however, has continued and the number of nations possessing nuclear weapons in their arsenals in 2005 has increased by 25 percent over those known to have had such weapons in 1995. Russia's conventional strength, its remaining nuclear capabilities, and its achievements in space, however, remain a potential threat to other nations and U.S. interests worldwide. This potential



military threat that appears to be emerging around 2005 reinforces the traditional alertness of the United States to watch the worldwide political and economic adventuresome activities of several of the new states of the CIS.

A factor often overlooked as being important to the effectiveness of a nation's military posture is its societal or local community attitudes. During the past decade or so, the U.S. military increasingly has gained an acceptance within local U.S. communities that is beyond usual economic or political interest. New military installations have been created relative to demographic population shifts which assure the military of an adequate share of needed specialized civilian skills as well as transportation and resource accommodations. The positive military attitude toward the preservation of the local community's natural resources and toward environmental protection further contributes to the acceptance of the military's presence. This positive attitude, moreover, extends to the community in other ways also. For example: Use of nonspecific military training facilities in 2005 is available to local communities (beyond civil defense and disaster preparedness exercises) for civilian or joint civilian/military training in such nonmilitary programs as health, physical fitness and sports activities, and adult continuing education programs.

In response to the increasing imbalance of racial (whites, blacks) and ethnic (Hispanic, Asian, Black American, for example) groups in the U.S. population and the need to inculcate in all citizens the workings of American democracy, citizenship and constructive attitudes toward freedom, the U.S. Congress has passed an 18-month National Public Service (NPS) program for all citizens and noncitizen residents. The NPS program is currently in the implementation planning stage. NPS will assure citizenship for all, reduce welfare rolls, and by 2020, will provide a constant supply of workers and trainees for almost all federal agencies including the military services.

In 2005, the U.S. defense posture is highly capable of reacting to any threat across the broad spectrum of war. The U.S. strategic defense has been bolstered by successive achievements during the past decade toward the

accomplishment of a strategic space defense. Overall, however, U.S. defense strategy in 2005 relies less on nuclear deterrent forces and more on conventional land, sea, and air forces under an unfolding strategic space umbrella. Since the turn of the century, the U.S. military services gradually have increased in numbers of personnel, weapons, and equipment commensurate to U.S. foreign economic and military assistance programs, which are extensive in 2005. U.S. forces overseas serve more as a deterrent to local conflicts, as U.S. soldier ambassadors and as world peacekeeper forces, than they serve in actual warfighting. Their overseas activities are nonthreatening and are oriented toward assisting host nations to maintain a peaceful climate while they grow into free-market economies, democracies, and industrial statehood. The U.S. military services are organized under regional unified commanders-in-chief. In general, they are supported by single defense programs for logistics, communications, supplies, health, installation management, and other common functions.

The force structure of the BRAVO 2005 military (all services) is about 30 percent light (rapidly deployable) and 40 percent heavy (not readily deployable). While the BRAVO warfighting ground forces are equipped to fight with high-tech weapon systems primarily, they are still using some residual (and aging) 20th century conventional weapon systems, including tanks. The same situation exists for naval and air warfighters. The Active BRAVO 2005 ground force is comprised of about 800 to 900 thousand troops and is reinforced by a large Reserve component of 1.2 to 1.4 million troops. Both the Active and the Reserve component are supported by a civilian force of 350 to 450 thousand specialized personnel which includes a variable average of 25 thousand contract personnel who are primarily engaged in trial combat-training management and operations and other basic services. The other military services are also well endowed with personnel and have contracted many nonwarfighting activities to the private sector. The 2005 Reserve components can be 50 percent ready and deployable in about 30 days. The large number of host nation military support agreements permit reasonably rapid deployment of U.S. forces worldwide and

allow large amounts of equipment and supplies to be prepositioned and readily available in selected host nations.

Technology in 2005 readily assists transition from 20th century weapons and equipment to those of the 21st century. Training is especially advanced over that of the 20th century through the use of computerized simulators, robotics, simulations, and other electronic devices. Most training is with individual or unit simulators at collective, contract-operated training centers located regionally within the United States or in selected overseas host nations. Training, additionally, is joint or at times combined with host-nation forces. Some exploratory training using military personnel on manned space platforms is currently in progress. Planning for earthbound specialized installations also has been started to accommodate weapons technology advances for such weapon systems as directed energy, lasers, electronic magnetic pulse, acoustic, genetic, and electronic rail guns.

The firmly implanted trends of the BRAVO 2005 world suggest that over the next decade or so, the United States increasingly will become more heavily involved in all facets of international activity than ever before in its history as a nation. Not only will the United States be the economic mainstay of the newly industrializing countries (NIC) but it likely will also be the most advanced and influential leader of the postindustrial states; a titan among the nations of the world.

### **BRAVO 2020**

Internationally, the United States in the year 2020 is acknowledged by almost every nation as the foremost postindustrial state. It is also considered the colossus among the nations of the world. The United States is the world's model of national economic stability, growth, and leadership. Worldwide, the United States is a provider of benevolent economic and military assistance to selected countries for which overflight, port visitation, and basing rights as well as trading advantages for scarce resources are provided in return. Its international economic, sociopolitical, and moral influence is unsurpassed by any other postindustrial state. Most

importantly, the United States is recognized by just about every nation as the most advanced military power of the world.

During the past decade or so, the economies of almost every nation have grown significantly. This is especially evident in the nations (republics) that emerged from the former Soviet Union as independent and in the 1990s became members of the Commonwealth of Independent States (CIS), a temporary administrative body. The inability of the CIS to administer the republics adequately resulted around 2010 in the independent republics with like interests banding together for economic and security reasons to create a new administrative commonwealth of three new nations. The new commonwealth includes the following nations:

- the Union of Social Democratic Republics (USDR), principally Ukraine, a marginally accepted postindustrial nation;
- the Union of Sovereign Republics (USR), principally Russia, an industrial nation; and
- the Union of Independent States (UIS), principally composed of former Soviet independent, anomalous and ethnic groups. The UIS is described primarily as a preindustrial country.

Despite significant economic advancement internationally in the past decade or so, the USR remains an industrial state in the year 2020. The leadership of the USR is, however, showing increasingly more interest in the internal economic, social, and political development of its people as a nation than it did in the past and less attention to any of its former client states of the past century. The USR, nevertheless, remains quietly willing and capable of waging violent war if provoked.

By the year 2020 the world economy has become increasingly brisk and highly competitive. The postindustrial nations include the United States, Canada, all of Europe, the Union of Social Democratic Republics, Australia, and Japan. These nations formerly represented the leading world markets of the 20th century in heavy industrial products, automobiles, and other manufactured products. They are now the 21st century world leaders in high-tech products, services, information, and knowledge programs and systems. None of

the postindustrial nations show any inclination for military aggressiveness. Former 20th century industrial nations along with newly industrializing countries (NIC, formerly Third World countries) are supplying the world with heavy industrial products and most other high-demand manufactured consumer products. The industrial nations are keenly competitive in the world markets and are prone to occasional military aggressiveness short of war with a competitor.

Most nations of the world, except for the very poorest, are achieving a new economic prosperity that is expanding their horizons while, at the same time, altering their political and social infrastructures. The formal bilateral economic and political/military security agreements and treaties signed by the industrializing countries and the United States in the 20th century have been replaced by ad hoc agreements.

The highly competitive world economy along with a broad transfer of technology have generated an increased frequency of trade wars and political and economic power competitions. Notwithstanding, most of the industrial states are trading off a new growth of nationalism for economic development and investment as a solution to financial and unemployment problems. Along with the comprehensive U.S. foreign aid programs and the generous economic aid of the U.S. Government and its business corporations over the past decade or so, the former Third World countries have developed the skills and expertise needed to achieve industrial statehood. This economic diplomacy, over the years, has continued to strengthen U.S. international political and economic influence, has ensured the availability of scarce mineral resources, and, more importantly, has guaranteed U.S. military presence and in-country rights overseas.

The achievements of science and the advances of high technology in the postindustrial states by the year 2020 have offset the economic loss of heavy industries. Over the past three decades, the Western countries, the United States especially, increasingly have been importing steel, building and construction materials, and certain other heavy industrial and manufactured products. Until the development of plastic (polymer) munitions ordinance and lightweight, high-impact

armor plate in about 2010, the United States (for a short time only) imported ammunition for its military after the U.S. arms manufacturers moved to foreign countries and owners. Although the trade deficit increased early in the century, the introduction of new products and replacements developed by the specialty industries of the Western countries, e.g., those created in the high-polymer plastics industries, has reduced the deficit considerably. The continued efforts of science and technology, coupled with those of the specialty industries, provide the postindustrial states nearly full capability to support surge plans for most contingencies anticipated over the next decade or so.

National pride within the United States is as high as the economy is strong. Although the U.S. social and welfare program investment remains the foremost national budget expenditure, by 2020 the defense budget is almost equal to it. This has been brought about by new federal social programs with cost and investment responsibility available for optional assumption by, or shared partnerships with, the state governments or with industry and the individual reducing the social welfare budget expenditure to its lowest level in 25 years. The Defense budget in 2020 has increased substantially above those of the 1990s. These programs are followed in budget expenditures by national education, science and technology, environment, and space research and exploration.

Both the current Congress and Administration, as well as the general public, support extensive military programs. Almost all communities throughout the United States have accepted and approve of the military policy, which began around 2005, of sharing military facilities wherever and whenever possible. This program of sharing facilities has allowed an interchange between the military and the local communities that assists in resolving economic, resources, environmental, demographic, and attitude and value problems that are relevant to both military and civilian societies.

The National Public Service (NPS) program, enacted in 2005, was fully implemented by 2015. Since that time, the NPS has provided a constant flow of qualified Americans through 18 months of training in an agency of the Federal Government.

The most intensive training has been in the military. NPS has provided the military with qualified trainees, many of whom after NPS training have chosen to continue a career in the military. NPS has also bolstered the general economy and has helped to reduce national unemployment problems.

Most nations of the world, except the very poorest, have been highly armed by the new weapons merchants of the industrial states. The number of nations with nuclear weapons and delivery systems in their arsenals has increased by 25 percent over those known to have had these weapons in the early years of the century. This greatly increases the potential deliberate or accidental use of a nuclear weapon or device. Subsequent to the breakup of the Soviet Union in the 1990s, nuclear arms agreements resulting from significantly improved relations between the United States and the new confederacies (USDR, USR, and the UIS) have resulted in a significant reduction of nuclear arms when compared to the 20th century. The inclination to use military power, however, remains low as the USDR and USR try to establish economic stability and leverage in world politics.

The Union of Sovereign Republics (USR) has made progress since the turn of the century in modernizing its internal social and economic status. It has also made significant strides in its international diplomatic relations and its status in the world's free-market economy. The USR, however, remains dissatisfied to be labeled an industrial state while the United States and the USDR are recognized as postindustrial nations in the eyes of the rest of the world. The USR by 2020 is considerably more adventuresome militarily than before the turn of the century. For the past decade or so it has provided military arms and training to other industrial and preindustrial states, while at the same time, it has become increasingly more adventuresome economically in foreign markets. Moreover, the USR leadership has not only encouraged an economic fusion of some East European states with the European Community (EC), but also is seeking membership itself. Further, the USR has become involved in somewhat speculative economic international trade ventures of its own that are interfering increasingly with U.S. trade relations. The

USR, for what it lacks in economic know-how, remains highly capable of military intervention worldwide or of waging war despite the apparent disinclination of its leadership to do so. The army of the USR, however, is a significant challenge to the U.S. military and one for which the United States must remain prepared.

The U.S. military maintains a high level of readiness and is prepared for all foreseeable contingencies. By the year 2020 technological achievements and innovations have provided an opportunity for all military services to increase their warfighting capabilities. Technology, additionally, has increased the overall requirement for operational training, while at the same time has displaced a substantial number of military personnel required to conduct operations. Contracted training programs for the U.S. forces as well as foreign forces under military assistance and training programs are mostly accommodated by simulations and the use of simulators at installations in continental United States (CONUS) or overseas. These programs permit a large variety of joint/combined contingency plans rehearsals. During the year 2020, e.g., a 90-day major mobilization exercise in Southwest Asia is planned for the purpose of testing and comparing the reliability of the BRAVO 2020 military/contractor operational training simulations at any conflict level. Many training activities for the U.S. forces are performed by civilian contractors who use multi-environmental, functional training centers in CONUS and abroad, land-based or afloat. Training programs, as well as weapons and equipment development, stress environmental safeguards and the preservation of natural resources. The concept of environmental protection is incorporated in all activities of U.S. forces with special units assigned a restoration task.

The BRAVO 2020 world provides the U.S. armed forces—land, sea, air, and space—an opportunity to build an all-purpose military force structure and specialized forces for any contingencies. For example, the U.S. land forces in BRAVO 2020 are organized principally as a large standing Army of specialized, highly deployable active brigade-size warfighting units. The Active BRAVO 2020 Army is a large component of about 800 to 900 thousand troops. Combat



forces are 40 percent heavy (not easily deployed), 50 percent medium, and 10 percent light (easily deployed). The Active force is supported by a Reserve component—the Army National Guard (ARNG) and the U.S. Army Reserve (USAR)—approaching 1.6 to 1.8 million troops and a highly technologically trained civilian component of about 200 to 250 thousand personnel. The total force is 60 percent high-tech. Additional support to the Army, especially the ARNG and USAR, is provided by the National Public Service program of 2005. In general, the quality of life for BRAVO 2020 Army personnel in all respects is equal to or better than that of their civilian counterpart.

Operationally, the BRAVO 2020 Army fully uses space-age technology and weapons under highly advanced stages of strategic defense. Twentieth century heavy equipment/ weapons, e.g., tanks, have been replaced with light, easily transportable systems. Such systems are sustainable, automated, computerized or robotic, use near-earth and space transport and platforms, and are BRAVO 2020 Army force multipliers.

The role of the BRAVO 2020 military forces is to support a "big stick" deterrent strategy which complements the U.S. nuclear deterrent. Its force structure design is more than adequate for a broad range of contingencies from major war to small coalition warfare, to foreign internal defense or localized international unrest. The U.S. armed forces of BRAVO 2020 also serve other nations of the world as a peacekeeper in other types of civil strife through a global presence.

## **CHAPTER 6**

### **THE CHARLIE SCENARIOS: NEONATIONALISM WORLD**

#### **CHARLIE 2005**

The rise of nationalism worldwide in scenario CHARLIE has significantly suppressed U.S. political, economic, and military influence and has eliminated the presence of the U.S. military forces and most American industries overseas. CHARLIE is a highly competitive world where economic trade wars, embargoes, and restrictions abound. Despite sincere interests of the United States to provide assistance to the newly industrial countries (NIC), their leaders have turned to nationalism.

The United States, one of the foremost postindustrial nations of the world, along with many of its businesses and industries, have, over the past decade (1995-2005), provided continuous economic assistance to the NIC for the modernization of their industrial infrastructure. U.S. military and economic assistance, however, has been decreasing over the past decade as 20th century U.S. alliances and agreements weakened or were abrogated and abandoned. In most instances, U.S. forces have been withdrawn from, or their numbers reduced significantly in the NIC. The economic growth of many of these countries by the year 2005 has surpassed that of any other previous year. A few of these countries, concerned with the adverse influence that modern industrialization, technology, and Western ideas are having on their national cultures, have resorted to aggressive acts of nationalism. They have nationalized several U.S. industries as well as those of a few other foreign nations, have expelled all foreign civilians and military, and have reclaimed all U.S. military bases located in their territories. Several other NIC are threatening that they also are planning to nationalize foreign

industries. The United States faces the relocation of its overseas forces, despite its efforts to halt this spread of nationalism, to alleviate NIC fears of irreversible cultural changes, or to retain a minimal U.S. military presence. The personnel in these forces must be moved to off-shore, floating bases, to other overseas bases that are in U.S. territories, returned to installations within the United States, transferred to Reserve status, or discharged from the services.

Complicating the problem of restationing U.S. forces withdrawn from overseas have been growing trends in U.S. local communities to block any further increase in the number of installations and the number of troops at existing installations or the assignment of any new type of military weapons activities to these installations. These community attitudes have grown out of several currently popular trends: an increased concern for community environmental protection, an infringement of local community populations on some military installations, and community economic self-sufficiency. This self-sufficiency has been brought about by new employment opportunities and an increased tax base generated by expanding high-tech and information/services industries. The apparently antimilitary attitudes of the U.S. communities are not associated with any international organization nor is the local intent one of disloyalty. Public support for the military actually is high; these local communities just do not want the military in their backyards. Similar attitudes against U.S. overseas and NATO bases also have existed in Western Europe (as well as in Turkey and Greece), and South Korea over the past decade or so.

The U.S. political leadership of the Administration and the Congress faced with these problems is mindful of the need to maintain a strong national defense posture to counter any military threat to U.S. interests. Since the turn of the century, the Administration has convinced the Congress to provide substantial multi-year defense budgets that have supported the initiation of comprehensive long-range defense plans. These plans redesign and strengthen the U.S. military posture through investments in the research and development of advanced technological military systems and the field testing

of new 21st century weapons. The long-range plans include the use of space to support basic military systems for earthbound combat operations, such as communication, navigation, and logistics (prototype logistic and staging platforms are already in place). The Administration also has introduced as part of its long-range planning a comprehensive program for a federal/state financed Universal Public Service (UPS) program that, once operational, will provide trained personnel to almost all federal, state, and local government agencies, including those of the military. Overall, these long-range plans will reestablish and sustain the United States as the leading political, economic, and military power of the world, despite the weakening effects of the loss of overseas bases, should such trends continue in the coming years.

The immediate effects of the defense plans will create a smaller, more effective military force by 2010; one whose capabilities are enhanced by available technological force multipliers, such as advanced weapons, mobility, and logistic systems. These systems, new generation high-tech air and land weapons, and in-place prototype sea, air, and space platforms (bases) will enable the military to react to the conflict contingencies envisioned in the near- to long-range future. These contingencies, for the most part, are at the low- to mid-intensity level of the spectrum of warfare.

Over the past several decades, many of the heavy industries, primarily of the postindustrial nations (United States, Canada, a united European Community, and Japan), have relocated to foreign countries where economic conditions and available manpower appear to be more favorable. The loss of these industries has left these nations nearly unable to mobilize sufficiently to provide the production requirements of warfighting. Specialty industries, such as plastics, however, are only now approaching the capability to support industrial surge requirements.

Since the late 1990s and early 2000s, the North Atlantic Treaty Organization (NATO), increasingly is becoming more of a shell than an effective collective military alliance. This is partly due to growing apathy on the part of the European member nations and declining interest on the part of the United States.

It is also largely due, however, to an absence of any perceived threat by the Europeans to their individual or collective sovereignty or to their political or economic systems. The dissolution of the Warsaw Pact and the breakup of the Soviet Union in the late 1980s assured this and was accompanied by agreed bilateral mutual troop and nuclear force reductions between Russia and the United States. These changes along with the demise of Soviet communism have resulted, over time, in the abandonment of the Alliance, including its armed forces. Only France and the United Kingdom have retained their force structures and France, its nuclear systems. By 2005 the U.S. forces that supported NATO in Europe were reduced to only a caretaker contingent (about 5 percent of the total number of forces there in the 1980s). European NATO members have not only failed to replace the U.S. forces, but also have significantly ignored their own commitments to the Alliance.

Russia, the largest, most powerful confederacy and preeminent force emerging from the former Soviet Union, resumed a negotiating position with the United States in the 1990s. Moreover, it accelerated the bilateral mutual troop and nuclear forces reductions which began in the late 1980s during the administration of the Commonwealth of Independent States (CIS). The CIS was a temporary administrative body that held the newly independent republics of the former Soviet Union together, but retained too great a tie with the former system to be truly representative of the Republics.

Seizing the opportunity during the years around the turn of the century, anti-American, buy European, peace, and environmental activists' movements have brought about further degradation of the Western Alliance. Gone also are the close relationships once held between the United States and Europe as they become increasingly competitive economically. Not only has U.S. military presence declined in Europe but also has European-located American industries. By 2010, only about 20 percent of the 1990 level of U.S. owned enterprises will remain in the European Community. The contingent of U.S. forces along with the remaining European and French military forces are believed by the Europeans to

be sufficient as a primary deterrent to war between Western Europe and the fragmented East European nations or the independent republics of the former Soviet Union. The Western Europeans, rather than increasing their military forces, are banking on serious economic overtures that will encourage the East European nations to join the European Community (EC). This, the West Europeans believe, will surmount any military threat.

Over the next decade or so, the most likely conflicts to occur would be unconventional and insurgencies; less likely would be conventional, high-tech conflicts; and least likely would be nuclear conflicts. These estimates are based on the continued proliferation of conventional/high-tech, and nuclear weapons during the latter years of the 20th century and the early years of the 21st century.

Most of the nations of the world, except the very poorest, have been armed by 20th century arms merchants with that era's conventional weapons; some, additionally, have acquired late 20th-early 21st century high-tech weapons and missiles; and others have added chemical, biological, and nuclear weapons to their arsenals. The number of nations possessing nuclear weapons and delivery systems in 2005 has increased by a third, over those known to have had such weapons a decade ago.

Subsequent to the independence movements of the former Soviet republics, temporary political management was given first to a residual centralized body, then to the Commonwealth of Independent States (CIS). The United States provided diplomatic recognition and economic aid to each republic as it proclaimed its independence. The specific interests of the United States, however, were first to assure that a divided Soviet Union was created and then to make certain that a reduction of the number of former Soviet nuclear weapons rapidly occurred. To help this along, the United States entered into nuclear arms reductions agreements with the CIS and Russia and provided skilled technical assistance for the dismantlement of these weapons.

The former Soviet republics are not actively involved in any external conflicts in 2005, although some internal strife of ethnic origin occurred earlier. The Russian Republic continues to support some of the former Soviet client states, however, but to a much lesser extent than it did before commencement of mutual nuclear arms reductions with the United States in the late 1980s. Increasingly since that time, the primary interests of the Soviet then Russian leadership, and subsequently the leadership of the other former Soviet republics, have been national economic, political, and social reform and development. Success in making the transition from a centralized economy and government to a free-market system and a democratic representative government has become the foremost driver of these societies. Some republics recognize that for them to survive in a highly competitive world economic market there is a need for those with like interests to pool their assets in a new cooperative confederacy.

The same leadership of these new independent nations, especially Russia, is demonstrating a cooperative attitude toward maintaining the incremental bilateral agreements with the United States. Special attention, in this respect, is given to inspection of former nuclear sites and verification of dismantled and destroyed weapons and warheads. Although less inclined toward military aggressiveness since before the mid-1990s, the republics of the CIS still retain a conventional military capability. While this military has been withdrawn from Eastern Europe, it is contained in several republics, but is somewhat in disarray and is not perceived as a threat to Europe, the United States, China, or India.

U.S. military leadership in 2005 is keenly aware of the existing CIS warfighting capabilities and the conflict potential of a highly competitive economic world. Moreover, the military realizes the need to maintain a strong U.S. military posture. It also believes that the restructuring of each of the services commensurate to the stationing limitations imposed in the 2005 environment is necessary. Regardless of limitations, U.S. military leadership believes that the development of new technology- and space-oriented military strategies will provide a U.S. warfighting capability that will be an effective worldwide

deterrent to any individual member of CIS or renewed worldwide collective aggressiveness from former Soviet states.

The U.S. force structure in 2005 continues as three separate service departments, although logistics, personnel, and communications for each are now under the single control and management of the Department of Defense (DoD). Troop transport, in general, is largely by civilian contract as are base facility support and medical health care and services. The arrangement assists the services in being more reactive to worldwide threats to U.S. interests and to fulfill their primary mission, defending the United States. When called upon, U.S. forces provide defensive assistance to former U.S. allies and friendly nations at a force level commensurate to the threat and with an appropriate mix of the services to resolve the threat issue or terminate a conflict as quickly as possible. The force structure and end strength of the Army, whose mission is ground defense, is designed to accommodate this strategy of measured force, i.e., a force tailored to the threat and type of conflict anticipated. What is happening to U.S. military forces by 2005 can be described by using the Army as an example.

The Active component (AC) of the Army in CHARLIE 2005 is about 30 percent light (man intensive and rapidly deployable) and the Reserve component (RC) is about 40 percent heavy (equipment intensive and not as readily deployable). This force structure has evolved as circumstances have forced the United States to withdraw more than 50 percent of its overseas forces. Additionally, as a result of this situation, Congress has amended Title 32 and the RC now combines the National Guard and the Army Reserve into a single component. This 2005 RC is organized, equipped, and trained in the same manner as the Active Army. The end strength of the AC in 2005 is about 350 to 450 thousand troops and the RC is about 1.1 to 1.2 million. The RC is capable of rapid mobilization equally from home stations and regional training centers. The supporting civilian component is about 150 to 250 thousand personnel who are highly trained and integrated with AC and RC, and are selectively required by contract to stay in place in the event of war.



To accommodate the national security needs of the postindustrial United States, manage available manpower, and furnish appropriate and affordable 21st century training, the 2005 Administration has introduced a National Defense Force (NDF) plan. When enacted by the Congress and implemented by DoD, NDF will produce a one uniformed service in the United States. The NDF is expected to be fully operational within the next decade or so.

The CHARLIE 2005 Army is organized, equipped, and trained as small, readily mobile fighting units that are stationed increasingly in sparsely populated areas in the United States. The Army is organized to fight in a configuration that stresses self-containment and self-sustainment under hazardous conditions for 40 days duration before unit replacement, while individual replacement is during combat. Resupply is mostly by air or sea (surface and subsurface) logistic units, and eventually from space (platforms or bases) when development is complete. The Army is equipped with a mix of late 20th century (about 40 percent) and early 21st century (about 60 percent) material, weapons, and ancillary systems. Most of the 20th century weapon systems, such as the tank, are obsolescent and are being phased out of inventory. Where feasible, about 90 percent of all new equipment and systems are computerized as well as hardened and shielded. Increasingly, routine, boring, and hazardous tasks are robotized (about 75 percent) also, including ground surveillance, transportation, and decontamination.

Both men and women of the Army increasingly are trained for combat operations by simulation and simulators under civilian contracts which use especially designed computerized facilities that are space savers (e.g., half above/half below ground level) at regional Army installation training centers. Additionally, the Reserve Component is involved in exploratory training in the use of the prototype air, sea, and space logistic and staging area platforms. The Reserve Component is organized and equipped the same as the Army AC and both train together at the regional training centers. Although available land for field training is becoming increasingly scarce as local U.S. communities become more critical of Army

environmental pollution, a few stateside locations away from dense populations remain available. A few overseas locations in friendly countries where U.S. bases still exist also provide possible additional land where field training can be conducted.

## **CHARLIE 2020**

The United States over the past decade and a half has been faced with the withdrawal of all of its military forces from its overseas bases, including the former NATO countries and those in the newly industrializing countries (NIC), formerly Third World countries. Also during this period, with the generous help of U.S. economic aid and U.S. private corporation advice and financial assistance, the international status of many of the NIC has been gradually transformed from preindustrial into industrial. Many NIC, also during this period, have adopted more representative, mostly parliamentary, forms of government more compatible with a free-market economy and the economic growth they are now experiencing. Believing that, since the beginning of the century, the influx of Western technology, people, and ideas has been changing their societies and obscuring their national identities, most of these nations are now seeking refuge in a revived nationalism as others had in 2005.

Increasingly, over the past decade or so, many of the NIC have become more intimidated by, and apprehensive of, the technological changes that accompany industrialization; free-market economies; and democracy. They also were becoming more protective of their cultures and their countries as they turned to nationalism. Regardless of treaties, military agreements, or other arrangements with the United States, these nations, which had previously welcomed American presence, have nationalized foreign industries, expelled U.S. and other foreign nationals, and denied overflight and port-visitation rights, and reclaimed all U.S. military bases on their territories. This rise of neonationalism worldwide has suppressed U.S. opportunities for international political and economic influence and is forcing the United States to rely on its strategic resources stockpiles.

The United States in the year 2020 is the foremost postindustrial nation of the world. Over the past several decades, the United States has advocated, supported, and maintained a strong military defense. Its investments in technologically advanced military systems, especially those using the fourth dimension of space, have surpassed any previous military investments. Such systems have reduced the military requirement for massive land forces and allowed military strategists to devise technology- and space-oriented strategies that will accommodate a 21st century U.S. military force as well as counter traditional strategies of land warfare. Such innovativeness is essential to the United States, especially its military, since nearly all U.S. heavy industries, including arms manufacturers, have relocated to foreign industrial or preindustrial nations since 2005. This relocation of heavy industry has occurred in almost all other Western postindustrial nations as well as in Japan. A decade ago, this situation had left the United States and other postindustrial nations in a transition where their infrastructures appeared unable to provide military equipment or weapons in the event of a need for industrial surge. By the year 2020, the U.S. high-polymer plastics industry has perfected precision designed, lightweight munitions ordinance and armor plate that can be produced in the quantities needed for military purposes.

During the past 15 years, the increasing migration of high-tech, service, and information workers to the city areas has brought these cities closer to the creation of east/west and north/south megalopolises. More communities are expanding adjacent to military installations in 2020 and more demands are being made for these installations to close or find other locations. Forces returning from overseas have been deactivated and units and individuals have been assigned to the reserves to reduce the military population around the most congested cities.

The long-range defense plans and the substantial multi-year defense budgets approved by the 2005 Congress have assisted the Department of Defense (DoD) to acquire the necessary advanced technological equipment and weapons needed to maintain readiness with a minimum of combat

forces. They have also assisted DoD in the development of space systems to support earthbound combat operations. Additionally, of the prototype space platforms developed and in place in 2005, the logistic platform is operational but the troop staging platform is useful only for small special operations activities. Between the years of 2005 and 2020, the federal and state financed Universal Public Service (UPS) program has been passed by the Congress and approved by two thirds of the state governments. UPS is now inducting trainees for 18 months of service in almost all agencies of federal, state, and local governments.

Almost all of the nations of the world, except the very poorest, have been armed with 20th century conventional weapons and ancillary systems and early 21st century high-tech weapons. A new generation of arms merchants since the turn of the century have continued the sale of arms and other military equipment. These merchants have increased the number of nations possessing nuclear weapons and delivery means 25 percent over those nations known to have had them in 2005. Most of the industrial nations of the world, although achieving moderate to high economic growth, increasingly are unable to cope with the highly competitive challenges of the world economy. Although these nations are dissatisfied with their economies and are disinclined to resort to war to get the best of economic competition, their possession of nuclear weapons is a growing concern to peace.

By 2020 a new temporary administrative commonwealth has replaced the now defunct Commonwealth of Independent States (CIS). The new commonwealth is attempting to continue with programs of economics and social development to assist three new confederacies. One is the Union of Sovereign Republics (USR), led by Russia, and another is the Union of Social Democratic Republics (USDR), led by Ukraine. The USR and the USDR are comprised of other former Soviet republics that have similar interests, principally economic security, that have joined together to form new nations. The leaders of both of these confederacies have continued sincere cooperation with the United States in conventional arms control, nuclear arms reductions, and in inspection and

verification. Moreover, they have maintained a peaceful attitude toward Western Europe. All of their forces have been withdrawn from Eastern Europe since 2005. Although the USR and USDR still retain a conventional military capability, they are perceived by the West not to pose a threat to Western Europe. There remains a serious problem, however; not all of the former Soviet tactical and strategic nuclear weapons and delivery systems have been accounted for.

The United States and Western Europe believe that an undetermined number of tactical and strategic nuclear weapons and delivery systems have been secretly sold or given away to other foreign governments or have been stolen and secretly hidden by disgruntled, former Soviet military and civilian communists in a new confederacy. This is the third confederacy of the new administrative commonwealth and is called the Union of Independent States (UIS). It is made up of former independent and anomalous states and ethnic groups of the former Soviet Union that have joined together to assure that they are represented in the new commonwealth. The leadership of the three confederacies are showing little interest in support for former client states of the former Soviet Union and have traded 20th century adventuresome military interests for national economic pursuits in a highly competitive world economy.

Around 2005 the then Administration introduced a bill to create the National Defense Force (NDF). The purpose of the NDF was to accommodate the national security needs of a postindustrial United States, manage available manpower, and furnish appropriate and affordable management and support for a 21st century military force. The NDF is a one uniformed service designed to accommodate land, sea, and air/space military operations. Congress approved the concept and appropriated funds for the DoD to begin the implementation of the NDF in early 2006.

The National Defense Force (NDF) is the unified warfighting force of the United States. The Active NDF has dual or multiple operational capabilities, e.g., air or space and land or sea; and is rapidly deployable from regional centers located away from dense populations. The NDF is essentially 100

percent high-tech and is equipped with high-tech throwaway (biodegradable) combat weapons, communications, and transport systems, many of which are robotic. Resupply is mostly by air and space logistic units. Training, individual and by unit, is predominantly by computer simulation and simulators that are linked to or are at local or regional centers. The Active force is supported by a large single Reserve component, (the National Guard and Reserve combined) which is organized, equipped, and trained identically to and combined with the active NDF at regional training centers.

The U.S. Army in the CHARLIE 2020 environment is organized as the arm of the NDF for land warfare and is comprised of small, self-contained, highly mobile, light (readily deployed) fighting units. The Active CHARLIE 2020 Army is a small component of the NDF with about 200 to 250 thousand troops, 40 percent of which are organized in light, self-contained, self-sustaining, rapidly deployable combat units. Additionally, Army combat forces are 10 percent heavy (not easily deployable) and 50 percent medium. The Active Army is supported by a larger, single Reserve component with about 1.2 to 1.5 million troops, which is organized the same as the Active component. All warfighting operations of the NDF land forces are fully coordinated with air/space, and sea operations.

The CHARLIE 2020 Army component is supported by a highly technically trained civilian force of about 100-150 thousand that is integrated within both the Active and Reserve component and contractually dedicated to service during war. The mandatory Universal Public Service (UPS) program provides a rotation of combat trained men and women who are selectively offered career opportunities after training. Most services (e.g., installation management, training, maintenance) are conducted under public contracts. In general, the quality of life for the Army component and other NDF personnel is modernized but austere (e.g., shipboard style living).

The role of the CHARLIE 2020 military forces, i.e., the NDF as a whole, is defensive and reactionary to serious threats to U.S. national security and interests and complements a

residual U.S. nuclear deterrent. The NDF is operationally trained for a range of contingencies worldwide with a capability to fight a conventional war strategy including chemical and biological warfare. The NDF is deployed from strategic locations in space, sea (surface and subsurface), and air or land from the United States.

## **CHAPTER 7**

### **THE DELTA SCENARIOS: MUTED MULTIPOLAR WORLD**

#### **DELTA 2005**

In the year 2005, the United States is one of the foremost postindustrial nations of the new century. It shares the status of postindustrial with Australia, Canada, Europe, and Japan. The U.S. economic infrastructure at the start of the 21st century is predominantly science based and technology oriented. Its economy supports information, services, and knowledge industries that employ about 60 percent of the U.S. population. Because the United States is recognized by other nations as a world economic leader, its foreign relations are good with almost every nation whether it has formal agreements or not. This general worldwide acceptance has strengthened U.S. political, economic, and military influence and preserved U.S. military presence in almost all corners of the globe.

By and large, the United States is respected worldwide for its willingness to provide economic assistance (monetary and advisory) and information exchange (management and technology) to other nations, especially nations that are transitioning from developing countries to modern industrialized nations. These are the newly industrializing countries (NIC) that look to the United States as a benevolent leader of world nations.

The United States is also respected for the stature of its military. Most nations believe that the U.S. military is well trained, armed with the most advanced weapons and technology of the 21st century, and highly capable of rapid and efficient warfighting operations worldwide. Its presence is quite visible around the world and provides an umbrella of protection for many small nations. These nations in return ensure that scarce resources are available to the United States and



provide port visitation, overflight, and basing rights for U.S. forces. The U.S. military, despite all outward appearances, is making difficult decisions, however, within the United States regarding its future. The military must make some hard choices relative to national security and defense in a multipolar world where conflict relates more to pricing wars than to shooting wars.

Over the past several decades, as many as 70 percent of U.S. heavy industries, such as steel, chemicals, and arms manufacturers, and about 45 percent of the lighter U.S. manufacturing industries, e.g., automobiles, appliances, and building construction and fabrication supplies, have relocated to foreign nations. Most of these industries have remained under American ownership or have arranged co-production agreements with or resale directly to foreign business concerns. Notwithstanding the loss of these industries, almost all sectors of the U.S. economy are flourishing (at about 2-2.5 percent growth per year) as are the economies of almost all the other nations of the world. A comparable relocation of heavy industries has taken place in other postindustrial countries, i.e., Canada, Europe, Australia, and Japan. These nations in 2005 still depend on steel armament for some 20th century military equipment, e.g., armored vehicles. It has been only during the past decade that the U.S. plastics (e.g., high-polymers) industries have perfected ordnance and lightweight, high-impact armor plate. Within about 5 years the U.S. military very likely will be able to field the new plastic ordnance and armored equipment. The industrial capacity of the postindustrial nations to support industrial surge requirements therefore is marginal, at best.

The U.S. economy in 2005 also supports light fabricating enterprises that produce automated and robotics products, electronic and optical specialties, and computer hardware and software. The fabricating industries employ about 10 percent of the U.S. population. Two other important industries of the U.S. postindustrial society are the plastics and the techno-agricultural industries, which employ about 10 and 5 percent of the population, respectively. In addition to their use in ordnance and armor plate, lightweight plastics increasingly

are replacing traditional structural building and plating materials. The technoagricultural industries produce a significant portion of the nation's food supply and, essentially, have replaced about 40 percent of the large farms of the past. They require less than a third of the land space formerly needed for late 20th century farming. About a third of the former farming land is occupied by new housing developments and high-tech industries; the remainder is now used for pasture lands, timber, and national parks.

Increasingly over the past two decades or so, there has been a growing public reaction by local U.S. communities, especially those that are contiguous to or within 25 miles of military installations, to the U.S. military's inability to cope with community environmental protection standards. The public's response has been directed further against the military's position that state environmental regulations are encroaching upon military installations and constraining the military's readiness in support of national defense. Reaction has been aimed at the military's lack of remedies for pollution of the air and the water table. This pollution is presumed to be caused by military systems and procedures (e.g., disposal of toxic wastes, transport of potentially toxic and hazardous substances, and noise). Moreover, response is also directed toward a presumed disregard of environmental conservation (e.g., wasteful consumption of natural resources, especially water). Despite the military's attempts to correct its procedures and decontaminate the most heavily polluted installations, the public reaction by 2005 has not stirred congressional response. Several states, however, have enacted environmental protection legislation that prohibits or severely restricts specific military activities within their states, such as the disposal of used petroleum, spent nuclear wastes, and the movement of obsolete chemical, radiological, and nuclear weapons. This has resulted in the closure of several military bases and their literal reduction to fenced-in and guarded toxic waste dumps. Additionally, during the late 1990s, public reaction to noise generation blocked the development of several artillery ranges and armored vehicle training installations.

Concurrent with this increasing and apparently antimilitary public attitude has been the growing economic independence of many local communities and the rising affluence of individuals; neither of which in 2005 needs the economic support of military installations. Such economic support is now provided by high-tech, services, and information industries that the local communities and states have encouraged over the past decade or so to locate in their areas. The employment and high wage opportunities offered by these industries have created population shifts and migrations, which, in turn, have created new housing developments and communities that gradually will encircle adjacent military installations. They are the beginning of potential east-west, north-south megalopolises. Further complicating the problems for the nearby military installations are the growing difficulties they are facing in competing for and attracting the high quality civilian personnel whose skills both the military and industries need.

Military manpower requirements are made more difficult by the national population age and ethnic distribution. In 2005, the average population age in the United States is about 38 years. In general, there are fewer 18-24 year-old youths eligible for military service. The ethnic distribution in the United States is approaching 28 percent blacks, Hispanics, and Asians. More than 50 percent of the available 18-24 years of age males and females are in this group. This population age and ethnic distribution can be expected to continue to rise over the next decade or so. Moreover, these groups increasingly will become more involved and influential in all aspects of national life. The U.S. national political leadership (the Administration and a small majority of the Congress), aware of the increasing social and economic problems of these groups over the past decade or so, has increasingly sponsored national social welfare programs and investments, especially in housing, health, and education, to raise their standard of living and increase their contribution and participation in the nation's postindustrial economy. Following the social welfare investment in the national budget are space, science and technology, and defense programs. Although national security and defense are budgeted lower than in past political administrations, the U.S. defense budget remains one of the

highest per capita investments of any comparable postindustrial nation.

Almost all the nations of the world, except the very poorest of the newly industrial countries (NIC), have invested in a military force armed with 20th century conventional weapons. Comparable to their perception of threats to their nation, some have small-to-moderate size military forces, while others have moderate-to-large forces and are armed additionally with more modern high-tech weapons of the late 20th and early 21st century. By 2005, the number of nations possessing nuclear weapons and delivery means has increased by 20 percent over the preceding decade. The United States, the new Commonwealth of Independent States (CIS) (a temporary administrative arrangement that came about after the breakup of the Soviet Union), and Russia are showing concern over this increase in nuclear proliferation.

The CIS in 2005 is involved in a continuing program to assist the former Soviet republics in their transition from a centralized to a free-market economy and raising the standard of living throughout the commonwealth. The CIS leaders no longer support client states and are showing no inclination toward promoting any new ideology. The CIS is more interested in economic innovativeness and experimentation than in military undertakings. Each of the CIS nations, however, retains residual conventional military capabilities left by the former Soviet Army, but they are not perceived as a serious threat to Western Europe. Despite attempts by the European Community (EC) to create its own military defense during the late 1990s, it still depends on a limited presence of U.S. forces and a linkage to nuclear forces as its primary deterrent. An assessment of CIS strategy by the EC nations suggests that the CIS leadership is attempting to reduce international tensions for whatever time is needed for the economies of the Commonwealth and the various societies of the former republics to acquire postindustrial statehood. This strategy has tended to be divisive among the new independent nations that are beginning to group together according to like needs and interests for their economic security. Around 2005 new CIS leaders express publically a more conciliatory air.

The combined impact of world and U.S. domestic trends and events on the U.S. military over the past decade or so increasingly has encouraged the Department of Defense (DoD) to reevaluate U.S. military organization, force structure, and, especially, where the military will be stationed within the United States. The mission of U.S. forces in 2005 continues to be the defense of the United States, its interests, and its allies. The defense posture for the next decade must continue to be highly capable of reacting to any threat across the spectrum of conflict. Since the start of bilateral (U.S./Soviet) nuclear arms reductions in the late 1980s, U.S. defense strategy by 2005 has relied more heavily on high-tech conventional land, sea, and air weapons for deterrence than on a nuclear strategy of deterrence. In the late 1990s new agreements continued to be made by Russia, a republic of the former Soviet Union and CIS that controls most of the former Soviet nuclear weapons.

The U.S. force structure has shifted from emphasis on separate services to joint commands. The total force is about 70 percent heavy (i.e., equipment intensive and not easily deployable) and about 30 percent light (i.e., man intensive and easily deployable) and includes specialized land, sea, air, and space elements. Logistics, communications, personnel, training, transportation, and installation facilities management and operations are all under DoD control and most have been placed under civilian contract arrangements.

A typical end strength of the 2005 U.S. military is the Army Active component (AC). It is about 700 to 800 thousand troops; the Reserve component (RC) strength is about 800 to 900 thousand; and the civilian support is 350 to 400 thousand specially trained civilians. Most of the training for the AC and RC is under civilian contract, including services and facilities, and is conducted both within the United States (60 percent) and overseas (40 percent). About 70 percent of the RC train on a rotational basis overseas with the Active forces. Mobilization is mostly from regional U.S. training centers.

Simulation is used increasingly by all services for training and new innovative simulators are used at regional training centers. Multipurpose centers provide similar programs for

concurrent joint service, Active and Reserve, training and are located in the United States at low-density population areas. These centers replace the installations that have been closed to accommodate environmental protection legislation. The Reserve forces not only train with the Active forces but also are manned, equipped, and structured similarly to them. Moreover, despite only a meager budgetary investment in advanced technological systems, e.g., robotics equipment and high-tech weapons, new innovative technological equipment and the doctrine and strategy for their use are equally shared between the Active and Reserve forces, and, where possible, jointly.

Because of the difficulty in manning the U.S. military, Active and Reserve, with qualified men and women in the 2005 demographic environment, DoD has considered but ruled out for the time being the need for compulsory national service based on marginally acceptable end strengths and the perceived ability of the military to fulfill its mission. At current strength, the military services are capable of performing their missions of land, sea, air and space defense and, further, are nearly capable of conducting offensive operations across the broad spectrum of conflict since the requirement for tactical nuclear operations has been reduced.

## **DELTA 2020**

Over the past decade or so, U.S. communities increasingly have rejected the presence of military bases contiguous to or within 25 to 50 miles of major cities. East-west and north-south patterns of urban sprawl throughout the nation are beginning to form vast megalopolises that are encircling remaining military bases and installations.

Many U.S. communities vehemently oppose any increased installation investments made to accommodate strange and new weapon systems that might pollute their environment and consume their resources. Since 2005, additional states have enacted environmental protection legislation that is so stringent that many military installations within those states have been forced to close. Recently, organized groups of

citizens, condoned by state governments, have blocked the addition to, and creation of, installations for new military systems, troops, and training programs. These groups believe that any changes in the status quo of the military would increase the risk of their communities to additional environmental pollution by military activities or make them targets of terrorists or of enemy attack in the event of a major war.

Most U.S. communities are economically viable and have little need for the economic support provided by military bases. Politically, most communities are represented by an older population and one that is approaching 40 percent blacks, Hispanics, and Asians combined. On the average, the same representation exists in state and federal governmental bodies. The political, economic, and social influence and impact of this near majority on U.S. national and international affairs are substantial. This impact affects U.S. society in general, but is especially reflected in the response of U.S. national political leaders who advocate comprehensive, national social welfare programs and investments. These programs are followed by investments in education, space, science and technology, and defense programs. The defense budget, however, has been reduced to considerably less than the defense budget of the late 1990s.

The United States is the leading postindustrial nation of the world. A very large percentage of Americans are employed in the services, information, and knowledge sectors of the U.S. economy. Heavy U.S. industries, such as steel and chemicals, as well as most manufacturers of automobiles, appliances, and building supplies have relocated to foreign nations from which the United States imports such needs. Specialty industries such as plastics (e.g., polymers) and high technology industries support the U.S. economy, which is flourishing. A comparable situation exists in the other postindustrial nations of Canada, Europe, Australia, and Japan. At the turn of the century, most Western strategic analysts believed that the postindustrial infrastructures, along with their specialty industries, lacked the capacity to support national industrial surge requirements in the event of a major war. The plastics

industry has proved this wrong, since a decade or so ago, it developed plastic ordnance, and lightweight, high-impact armor plate, and has recently developed building construction beams.

Worldwide, over the past decade, many nations have traded nationalism, which had been growing since the turn of the century, for economic security and development. This has strengthened U.S. international political, economic and military influence and has preserved U.S. military presence, bases, and installations overseas. These countries also welcomed American businesses, and their managerial expertise in the free market. Within this arrangement, these nations not only receive financial assistance from the United States, but also information, services and training, and most importantly, a security umbrella.

Most nations of the world, except the very poorest, remain heavily armed with conventional weapons. Others, additionally, are armed with more modern high-tech weapons systems. The number of nations with nuclear weapons and delivery systems has increased by two since the year 2005. The Commonwealth of Independent States (CIS), beset with constant economic setbacks, has been replaced by 2005 by a new temporary administrative commonwealth. It has three member confederacies: the Union of Social Democratic Republics (USDR), principally Ukraine; the Union of Sovereign Republics (USR), principally Russia; and the third, the Union of Independent States (UIS), which is made up of a number of independent, anomalous and ethnic groups of the former Soviet Union. These confederacies are bent on national economic catch up to enable them to achieve increased competitive advantage. They have, therefore become more adventuresome economically than militarily. Militarily, the USR and USDR leadership, unlike the former Soviet Union, no longer train and provide arms to client states; increasingly, however, they involve them in economic experimentation. Although the USR and USDR conventional warfighting capabilities remain substantial in 2020, they do not pose an immediate threat to the European Community since their interests, for the time being, have turned toward continued



internal economic development and completing the transition to democratic government.

U.S. defense programs in the DELTA 2020 world are austere. The economic benefits and military security that are provided to host nations by U.S. installations overseas have strengthened U.S. international political, economic, and military influence. These overseas installations accommodate U.S. military training and offer opportunities for the acquisition of additional land to expand training for U.S. reserve forces as well as U.S. military assistance programs.

The DELTA 2020 military force structure is organized as a single Unified Defense Force (UDF) made up of the Army, Navy, and Air/Space forces in a mix of generalists and specialists. The Army includes light (easily deployable) Army divisions which complement heavy (less deployable) Army divisions at a ratio of about 40:60 for both the Active and Reserve components of the Army. The UDF of DELTA 2020 has increased the use and activities performed by contractors. For example, contractors are used for administration, medical and personal services, and as pilots for noncombat activities. This has made more personnel available for the fighting force and, at the same time, has decreased the deployable combat logistic tail and sustaining base. The Active military are 75 percent high-tech and are equipped with robotics systems, modern weaponry and technology, and lightweight plastic (polymers) transport and fighting vehicles appropriate for land, sea, and air combat operations. The Army and Air National Guard and Reserve work closely with the Active components. The Reserve component is manned and equipped similarly to, and trains constantly with, the Active component within the UDF operational training programs. The UDF training programs support a total force concept where, within the United States, the UDF trains together as one entity at regional centers. The UDF is manned by highly educated, goal-oriented men and women of diverse ethnic origins from an information- and service-oriented postindustrial society. However—a draft may be needed to provide the required UDF staffing.

The Active DELTA 2020 Army component provides an example of the relative size of the other services of the UDF. The Army is a large component of about 700-800 thousand troops. Its combat forces are 60 percent heavy (not easily deployable), 20 percent medium, and 20 percent light (easily deployed). They are supported by a larger Reserve component of about 800 thousand to 1 million National Guardsmen and Army Reservists who wear the UDF uniform. Civilian support to the Active Army and Reserve component includes about 250-300 thousand highly-trained personnel. The quality of life ranges from spartan during training to comparability with civilian pay and benefits after training. The primary role of the DELTA 2020 Unified Defense Forces is defensive but they are fully capable of offensive operations when needed. The UDF complements the U.S. nuclear deterrent and is operationally trained to fight a variety of conventional contingencies.

# ENDNOTES

## CHAPTER 1: THE PROCESS

1. The futures study, *A World 2010: A Decline in Superpower Influence* (Taylor, 1986) was used as the base-line scenario for the development of *Alternative World Scenarios for Strategic Planning* (Taylor, 1988, rev. 1990). The 1986 study was rewritten in 1990-1991 at the time of the Soviet Union's collapse and republished as *A World 2010: A New Order of Nations* (Taylor, 1992). This futures study brings the *Alternative World Scenarios* study (1988/1990 editions) into agreement with *A World 2010: New Order of Nations*.

2. These forecasts can be found in *A World 2010: A New Order of Nations* (Taylor, 1992).

3. The credibility of the scenarios (before revision) contained in this futures study was established originally by a general officer Study Advisory Group (SAG) during the course of the study's use in the *Long Range Stationing Study (LRSS) for the Army in 2020* for which the scenarios were designed. They were approved by the SAG Chairman, LTG Schwarzkopf, and recommended to the Major Commands for use in their long-range planning. The U.S. Army War College, Strategic Studies Institute (SSI) was directed by Chief of Staff Memorandum, U.S. Army (CSM 86-15-14, 6 November 1986, *Long Range Stationing Plan for the Army*) to assist the LRSS Group (created by the same CSM) during Phase I of the study by developing plausible alternative world scenarios in which the Army may be required to operate in the year 2020. The scenarios created by the author and used by the LRSS Group are described in revised form in this study. The LRSS Group designed and developed its long-range stationing model and process by planning against all four of the original scenarios. The initial members of the SAG included: LTG RisCassi and LTG Schwarzkopf, DCSOPS, SAG Chairman (in turn); Mr. Johnson, OASA; LTG Register, DCSLOG; LTG Heiberg, COE; LTG Jenes, FORSCOM; LTG Forman, TRADOC; and LTG Burbules, AMC. The disposition of these individuals on the revised edition of the scenarios was not solicited. Representatives of the HQ, U.S. Air National Guard and State HQ members, under the direction of MG Philip G. Killey, Director, Air National Guard, validated the scenarios during a 5-day workshop, 1-5 June 1992, and suggested changes in the text to fit "A New Order of Nations." The scenarios were used for their *1993 Air National Guard Long-Range Plan*.

4. All too often, planning is based against a single, unique scenario that has been derived from a consensus view of a continuation of current

trends. In general, a single view of the future tends to be deterministic and often shortsighted. A single scenario cannot be relied upon as a credible projection for the long range. For short-term planning (e.g., 0-2 years hence), however, a single, surprise-free scenario approach can be reasonably accurate, but is considerably less accurate than planning against a set of alternative scenarios for the same time period. For midrange planning (2-10 years), drawing out specific trends and achieving a consensus view becomes increasingly difficult, unless expert opinions are obtained through the use of Delphi, cross-impact analysis, or other expert techniques. For long-range planning (10-20 years), the range of uncertainties, e.g., regarding the continuity of trends and new trends and their impact on society, make the single scenario less manageable unless many assumptions can be agreed upon. The multiple- or alternative-scenarios approach tends to create and accommodate a more objective future than a subjective one. See Heydinger and Zentner, "Multiple Scenario Analysis," pp. 65-67, in Morrison, Renfro, and Boucher, eds., *Applying Methods and Techniques of Futures Research*, San Francisco: Jossey-Bass Inc., 1983.

5. For the work here, validity was established by Robert J. Murray, and others, *Harvard University Seminar on U.S. Army Long-Range Stationing Study*, John F. Kennedy School of Government, Harvard University, October 8-9, 1987. The principal participants included Mr. Robert J. Murray, Seminar Leader; Professors Richard N. Cooper, Joseph S. Nye, Jr., and Ernest R. May (all of Harvard); Lieutenant General Richard D. Lawrence (USA Ret.); and Army participants Colonels Robert B. Adair, LRSS Director; Stephen F. Rutz, LRSS Deputy Director; John J. Hickey, Jr., Chairman, Strategy and Planning Department, Strategic Studies Institute, U.S. Army War College, and the author of this book.

6. The Harvard University Seminar reviewed and evaluated the original scenarios and issued a report in which the members validated the scenarios and methodology. They found the original scenarios to be plausible and the methods sound. An excerpt from the "Executive Summary" of the Seminar Report states:

... The Harvard faculty participants who reviewed the LRSS agree that it was a useful exercise that can be extended to other areas of long-range military planning, and they were particularly impressed with the extent to which some of the LRSS scenarios challenged widely-held assumptions about the future structure of the Army. The faculty participants also found the basic methodology of the LRSS to be sound and the outlines of its four scenarios to be plausible . . .

An excerpt from the "Statement of the Seminar Leader" states:

. . . This methodology, by examining and discussing alternative futures, can help planners do a better job of describing for decision-makers the implications for our defense posture of alternative world situations. It could help provide a better context for the Extended Planning Annex of the Program Objective Memorandum. This methodology appears sufficiently promising for these larger purposes as to be worth exploring in detail.

7. A concept of the "cone of plausibility" was originated *circa* November 1986, during the early stages of planning for the stationing study by Stephen F. Rutz, Colonel, USA; Robert S. McEldowney, Lieutenant Colonel, USA; and Charles W. Taylor, Strategic Futurist, USAWC. Taylor expanded and clarified the concept, and redesigned and described the methods to increase their utility far beyond use in the Department of Defense. A literature search uncovered only one other similar concept of scenario plausibility: a U.S. House of Representatives Committee report: Preworkshop submission by Lynne Hall, "Public Issue Early Warning Systems: Legislative and Institutional Alternatives," October 1982, p. 235. Hall, in private telephone conversation with the author on December 16, 1987, related that her method of scenario projection was never published and was a different concept of the plausibility of future scenarios.

8. In considering how many scenarios to use in a set, the number, of course, can be unlimited. However, the human mind would be unable to comprehend the interrelationships of the near-infinite number of variables. A computer program would be needed to generate the cross-impact analysis. To reach the decision as to the number of scenarios I considered the following: One scenario is predictive or deterministic (no one can predict the future accurately except by chance). Two scenarios, usually, are best-case and worst-case futures. Three scenarios almost always provide a middle-of-the-road scenario between the best and the worst. Five scenarios or more tend to become increasingly over-whelming in data and cumbersome to manage. Moreover, their number encourages ranking, i.e., preferred, least likely, or most probable. Ranking is predictive of the future. Four scenarios, however, are manageable by the human brain and allow considerable flexibility in the number of variables that are adequate for logically forecasting future scenarios appropriate for long-range planning. See Charles W. Taylor, "Eliminate Future Shock," *CHEMTECH*, A Magazine of Chemical Sciences, Technology and Innovation, American Chemical Society, July 1993, pp.12-15.

## CHAPTER 2: THE EARLY DECADES OF THE 21ST CENTURY

1. This chapter is adapted and summarized from *A World 2010: A New Order of Nations* (Taylor, 1992). Although the new order of nations was described in the earlier study, *A World 2010: A Decline of Superpower Influence* (Taylor, 1986), the emphasis here is on the new order rather than the declining influence of the former Soviet Union and the United States. The purpose of the revisions and updating of the alternative scenarios is to examine new trends that have come into being and events that have taken place since the alternative scenarios were first published in *Alternative World Scenarios for Strategic Planning* (Taylor, 1988).

2. It should be kept in mind that *A New Order of Nations* is describing an arrangement or a ranking of the world's nations by loose categories of industrialization and modernization. *A New Order of Nations* is not a "new world order." A new world order describes a change such as sovereignty changing from the city-state to the nation-state to a one world government.

3. Taylor, *A World 2010: A Decline of Superpower Influence*, 1986.

4. The concept of the term "superpower" is basically of cold war vintage. Superpower connotes competitive political ideology and military strength on a global scale among other nations with theoretically comparable power. The concept serves little use internationally in an era of a single superpower. Since the fall of the Soviet empire, the United States remains the only nation of the world recognized by all other nations as a superpower. The rising of any other nation of the world to challenge this U.S. position over the next 30 or more years is unlikely. The United States serves itself and the world best by offering its leadership qualities than by imposing its position of power.

5. The concept of the term "Third World" is demeaning. Many of these nations are becoming industrialized and are referred to as newly industrial countries (NIC). "Third World" connotes a group of nations that are unsophisticated, backward, lacking in knowledge and resources, and unable and unlikely, despite their struggles to better themselves, to achieve any better. Further, it suggests that some of these nations are unwilling to make the sacrifices necessary to build an infrastructure to accommodate modern industrial statehood. These latter nations are more willing to demand and take advantage of the benefits they believe a poor "Third World" state should receive.

6. Europe throughout this study is treated as the single entity of the European Community (EC) with about 32 to 34 nation-states. It is also treated as the community it very likely will be after the turn of the century. There is a good chance that by 2005, and most likely by 2020, the EC will include both the 20th century nations that made up western Europe, as well

as almost all of the east European nations of the former Soviet bloc. Chances are better than even that by 2015 the formation of a truly united European Community (UEC) will exist. There is little likelihood that any of the republics of the former Soviet Union will be included in the EC by 2010 or 2020, except Estonia, Latvia, or Lithuania. It is also unlikely that any of the three confederacies, the USR, USDR, or UIS (as described in this study), will be members of the EC.

7. See Taylor, *A World 2010: A New Order of Nations*, pp. 16-21.

8. The general concept for the development of Table 5 is an adaptation from Graham T. T. Molitor, "The Information Society: The Path to Postindustrial Growth," in *Communications Tomorrow: The Coming of the Information Society*, edited by Edward Comish, 1982, p. 85; and also from Yoneji Masuda, *The Information Society as Post-Industrial Society*, 1981, pp. 29-33. The "Political Freedom" entry in Table 5 is an adaptation from a series published by Freedom House as a January-February annual report in *Freedom At Issue*, now, *Freedom Review*, entitled, "The Comparative Survey of Freedom." The annual survey was originated in 1973 and analyzed and reported by Raymond D. Gastil. It is now reported by R. Bruce McCollm. In this survey, nations are rated against comparative scales for political and civil freedoms. A politically free baseline is a fully competitive electoral process where those elected clearly rule. A civil liberties baseline is where freedom of public expression for political change is not closed and where courts protect individual expression. The survey also includes a partly free category where there is overlapping of either political or civil freedoms.

9. Data adapted from Carl Haub and Machiko Yanagishita, *1993 World Population Data Sheet of the Population Reference Bureau, Inc.*, April 1993.

10. This is adapted from American Council of Life Insurance, "Collapse of the Global Financial Superstructure," in its *Trend Analysis Program (TA' 23)*, Washington: Summer Issue 1983, pp. 15-18.

11. Constance Holden, "Simon and Kahn versus Global 2000," *Science*, Vol. 221, No. 4608, July 2, 1983, pp. 341-343.

12. Leon F. Bouvier, "Planet Earth 1984-2034: A Demographic Vision," *Population Bulletin*, Vol. 39, 1984, p. 18, believes that neither "capitalism as we have known it for the past 200 years and communism as it has developed over the past 65 years" will prevail through the 21st century and that the 'developing nations' demand for a New International Economic Order will meet with some success during the next 50 years."

13. *Ibid.* Bouvier, pp. 18-19, projects "democracy, as distinct from capitalism, will survive and thrive as it ceases to be bound by capitalist

ideology" and assumes the "democratic world's emerging social consciousness and will spread to include a greater sharing of the wealth with less advanced nations." Additionally, Bouvier suggests that both democracy and communism may be replaced by Ward's "Sociocracy" (from Bouvier, p. 35; Lester Frank Ward, *Applied Sociology*, New York: Arno, 1974, reprint of original published in 1906, exact edition could not be located).

14. Neither Gastil nor McColm forecast the probability of freedom. The comparative surveys present only estimates of the current year's situation and the progress made toward freedom in the previous year. The projections for the world 2010 in this study are based on the author's estimates of the future economic and political potentials of nations.

15. Theodore J. Gordon, "The Year 2050: Reflections of a Futurist," *The Lamp*, an Exxon publication, Vol. 63, Spring 1981, p. 30. John Gever and others in *Beyond Oil: The Threat to Food and Fuel in the Coming Decades*, 1986, believe that world oil production will peak around the year 2000 and that substitutes cannot fully offset the decline in petroleum before 2025. They also believe that U.S. oil and gas virtually will be exhausted by 2020. The actual date of the depletion of oil is not important; the reason for even mentioning it at all is to emphasize the point that one day there may not be oil to depend on. The substitutes and synthetics may not be efficient enough replacements unless science and technology are provided funds in the new century to discover and perfect these creations.

16. U.S. Department of Energy, *The National Energy Policy Plan: A Report to the Congress*, 1983, pp. 21-23.

17. Adapted from Taylor, *A World 2010: A New Order of Nations*, 1992, p. 50.

18. Adapted from Jacques Gansler, "The U.S. Technology Base: Problems and Prospects," in Margiotta and Sanders, 1985.

19. Arthur F. Manfredi and others, *Ballistic Missiles Proliferation Potential in the Third World*, 1986, pp. 5-6. Also see discussion by Richard F. Grimmett in *Trends in Conventional Arms Transfers to the Third World by Major Suppliers, 1978-1985*.

20. Taylor, *A World 2010: A New Order of Nations*, 1992, p. 64.

21. *Ibid.*; Manfredi.

### **CHAPTER 3: SCENARIO SYNOPSES AND ATTRIBUTES**

1. The basic drivers of the scenarios were originally identified at an initial workshop in 1985 that included members of the Long-Range



Stationing Study (LRSS) team and planners from the Army Staff, the Major Commands (MACOM), and the Reserve Component. For the purposes of this study, there appears to be no reason to change the political or economic elements as the basic drivers.

2. Community infrastructures include economies, politics, demographics, resources, religious and other attitudes and values, and other basic community elements or idiosyncracies peculiar to a locality that are likely to influence or be influenced by military activities.

3. See Taylor, *The Relationship to Forecasting to Long-Range Planning*, 1982.

4. The numbers in this report for Army responses (i.e., numbers and percentages of forces), here and elsewhere, are notional. They represent the best judgments of the Long Range Stationing Study planners as responses to the alternative strategic scenarios. For the purposes of this study update, there appears to be no reason to change their responses significantly.

5. Mr. Robert Murray and the other Harvard University, John F. Kennedy School of Government seminar participants provided expert and authoritative recommendations and contributions in their review of the attributes matrix for the original study published in 1988. The suggested correlations of attribute values to the scenario environments help to make the scenarios more plausible and increase their utility. The Seminar's contribution of a baseline column remains acceptable and thus it continues to provide planners a starting point for projecting national interests. What I have updated in the table relates to the demise of the Soviet Union. Rather than to look only at a short term of five or so years and project data relative to Russia, Ukraine, and the other independent former Soviet Republics or only of the Commonwealth of Independent States, I have projected to 2020 attributes for economic and military growth of the USDR and the USR as they are defined in *A World 2010: A New Order of Nations* (Taylor, 1992.)

## SELECTED BIBLIOGRAPHY

- Adamek, Joseph. "Centrally Planned Economics in Europe: Economic Overview 1985." *The Conference Board*, 1985.
- Air National Guard. *The 1993 Air National Guard Long Range Plan*. Vol 1 and Vol. 2. Washington: U.S. Government Printing Office, 1993.
- American Council of Life Insurance. "Collapse of the Global Financial Superstructure." *Trend Analysis Program (TAP 23)*, Summer Issue, 1983.
- . "New Immigrants, New Minorities" by Leon F. Bouvier. *Trend Analysis Program*, July 1986.
- Becker, Harold S. "A Tool of Growing Importance to Policy Analysts in Government and Industry." *Technological Forecasting and Social Change*, Vol. 23, 1983, pp. 95-120.
- Bell, Daniel. *The Coming of the Post-Industrial Society: A Venture in Social Forecasting*. New York: Basic Books, Inc., 1973.
- . *The End of Ideology*. New York: Crowell-Collier, 1961.
- Bouvier, Leon F. *Peaceful Invasions: Immigration and Changing America*. Washington: Center for Immigration Studies, 1991.
- . "Planet Earth 1984-2034: A Demographic Vision." *Population Bulletin*, Vol. 39. No. 1, Washington: Population Reference Bureau, Inc., 1984.
- Coates, Joseph F. and Jarratt, Jennifer. *What Futurists Believe*. Mt. Airy and Bethesda, MD: Lomond Publications, Inc. and the World Future Society, 1989.
- Cornish, Edward, ed. *Communications Tomorrow: The Coming of the Information Society*. "The Information Society: The Path to Post-Industrial Growth," by Graham T. T. Molitor. Bethesda, MD: World Future Society, 1982.
- Didsbury, Howard F., ed. *The Global Economy*. Bethesda, MD: World Future Society, 1985.
- . *The World of Work*. Bethesda, MD: World Future Society, 1983.

- Dizard, Wilson P., Jr. *The Coming of the Information Age: An Overview of Technology, Economics, and Politics*. 2d Edition. New York: Longman Inc., 1985.
- Gastil, Raymond D. "The Comparative Survey of Freedom 1987." *Freedom at Issue*, No. 89, January-February 1987, pp. 3-16.
- Gever, John, and others. *Beyond Oil: The Threat to Food and Fuel in the Coming Decades*. Cambridge, MA; Ballinger Publishing Company, 1986.
- Grimmett, Richard F. *Trends in Conventional Arms Transfers to the Third World by Major Suppliers, 1975-1986*. Washington: Congressional Research Service, The Library of Congress, May 1986.
- Etzold, Hon. Thomas H. *Strategy in the 21st Century: Alternative Futures for Strategic Planners*. Washington: Center for Naval Warfare Studies and Naval Surface Warfare Center, co-sponsors, January 15, 1990.
- Hall, Lynne. "Environmental Assessment." Preworkshop submission in *Public Issue Early Warning Systems: Legislation and Instructional Alternatives*. Hearing and Workshop by the Subcommittee on Oversight and Investigations and the Subcommittee on Energy Conservation and Power and the Committee on Energy and Commerce, U.S. House of Representatives. 97th Congress, 2d session, 1982. Washington: U.S. Government Printing Office, October 1982, pp. 235-266.
- Haub, Carl and Yanagishita, Machiko, *1993 World Population Data Sheet*. Washington: Population Reference Bureau, Inc., April 1993.
- Heller, Charles E. *Twenty-First Century Force: A Federal Army and a Militia*. Carlisle Barracks, PA: U.S. Army War College, Strategic Studies Institute, June 14, 1993.
- Huss, William R., and Honton, E. J. "Alternative Methods for Developing Business Scenarios." *Technological Forecasting and Social Change*, Vol. 31, 1987, pp. 219-238.
- Jones, Thomas E. *Options for the Future: A Comparative Analysis of Policy-Oriented Forecasts*. New York: Praeger Publishers, 1980.

- Kahn, Herman. "Some Comments on Multipolarity and Stability," *Discussion Paper*, HI-3662-DP New York: Hudson Institute, 1983.
- . *World Economic Development: 1979 and Beyond*. Boulder, CO: Westview Press, 1979.
- Kahn, Herman and others. *The Next 200 Years: A Scenario for America and the World*. New York: William Morrow and Company, Inc., 1976.
- Kahn, Herman and Wiener, Anthony J. *The Year 2000: A Framework for Speculation on the Next Thirty-Three Years*. New York: MacMillan, 1967.
- Kennedy, Paul. *The Rise and Fall of the Great Powers, Economic Change and Military Conflict from 1500 to 2000*. New York: Random House, 1987.
- . *Preparing for the Twenty-First Century*. New York: Random House, Inc., 1993.
- Lawson, Harlan A. *Beyond Tomorrow: A Look at 2050 A.D.* Military Studies Paper. Carlisle Barracks, PA: U.S. Army War College, 1992.
- Lepgold, Joseph. *The Declining Hegemon: The United States and the European Defense*. Westport, CT: Greenwood Press, 1990.
- Malthus, T. R. *An Essay on the Principle of Population*. Edited with introduction by Anthony Flew New York: Penguin Books, 1970.
- Manfredi, Arthur F. and others. *Ballistic Missile Proliferation Potential in the Third World*. Washington: Congressional Research Service, The Library of Congress, 1986.
- Margiotta, Franklin D., and Sanders, Ralph, eds. *Technology, Strategy and National Security*. "The U.S. Technology Base: Problems and Prospects" by Jaques Gansler. Washington: National Defense University Press, 1985, pp. 105-138.
- Masuda, Joneji. *The Information Society As Post-Industrial Society*. Washington: World Future Society, 1981.
- McColm, R. Bruce. "The Comparative Survey of Freedom 1993." *Freedom Review*, January-February 1993, pp. 5-20.
- Meadows, Donnella H. and others. *The Limits to Growth, A Report for the Club of Rome's Project on the Predicament of Mankind*. New York: Universe Books, 1972.

Modelski, George, ed. *Exploring Long Cycles*. Boulder, CO: Lynne Rienner Publishers, Inc., 1987.

Murray, Robert J. and others. *Harvard University Seminar on U.S. Army Long-Range Stationing Study*. Cambridge, MA: John F. Kennedy School of Government, Harvard University, October 8-9, 1987. (Organized and conducted by Trinity International, Inc., a subcontractor to CACI, Inc-Federal, under contract number MDA-903-87-C-0639, in support of the U.S. Army Long-Range Stationing Study.)

Naisbitt, John G. *Megatrends: Ten New Directions Transforming Our Lives*. New York: Warner Books, 1982.

Naisbitt, John and Aburdene, Patricia. *Megatrends 2000*. New York: William Morrow and Company, Inc., 1990.

Renfro, William L. "Future Histories." *The Futurist*, Vol. 21, No. 2., March-April 1987, pp. 38-41.

Schnaars, Steven P. "How to Develop and Use Scenarios." *Long Range Planning*, Vol. 20, No. 1, February 1987, pp. 105-114.

Taylor, Charles W. *Alternative World Scenarios for Strategic Planning*. Carlisle Barracks, PA: U.S. Army War College, Strategic Studies Institute, 1988, Rev. Ed., 1990.

———. *A Concept of A Future Force*. Carlisle Barracks, PA: U.S. Army War College, Strategic Studies Institute, November 2, 1981.

———. *Pilot Delphi Project, Part I: Project Summary; Part II: Project Event Forecast Analysis and Technical Report*. Carlisle Barracks, PA: U.S. Army War College, Strategic Studies Institute, December 15, 1985.

———. *A World 2010: A Decline of Superpower Influence*. Carlisle Barracks, PA: U.S. Army War College, Strategic Studies Institute, 1986.

———. *A World 2010: A New Order of Nations*. Carlisle Barracks, PA: U.S. Army War College, Strategic Studies Institute, 1992.

Toffler, Alvin. *Powershift: Knowledge, Wealth, and Violence at the Edge of the 21st Century*. New York: Bantam Books, 1990.

## **APPENDIX A**

### **ALPHA 2020: U.S. ISOLATIONIST A MINISCENARIO**

During the past several decades, most of the nations of the world have experienced a period of rising economic growth that has been increasingly challenged by an invigorated, but highly competitive, world economy. Most nations of the world, except the very poorest, are armed with 20th and 21st century conventional weapons and others with high-tech conventional weapons and systems as well. Nations with nuclear weapons and delivery systems in their arsenals have significantly increased in number since the end of the century.

The economic progress that most nations have made, along with the absence of any major wars over the past 30 years or so, has outbalanced an armed and militarily competitive world in furtherance of a peaceful but economically competitive world. The United States is a prospering postindustrial state. While part of the former Soviet Union is an industrial state striving to increase its economic growth and another part is marginally accepted as a postindustrial, adversarial relationships with the United States no longer exist. Currently, both the Union of Sovereign Republics (USR), the industrial state, and the Union of Social Democratic Republics (USDR), the postindustrial state, interests are turned toward internal economic and social development. They remain formidable military powers. However, they are becoming increasingly more adventuresome and unpredictable economically than militarily.

The United States, one of the foremost economic postindustrial countries of the world, has turned increasingly toward expansion of its social welfare programs over the past two decades. The U.S. economy in 2020 is skewed decidedly toward a social investment economy which comprises a disproportionate part of its national budget. Social programs are followed by national education, space, defense, and

science and technology programs. This same trend, however, is occurring in all other free-world nations as well.

Moreover, most of the heavy industries, those that made nations great during the past two centuries, essentially have disappeared from the postindustrial states of the United States, Canada, Europe, Australia, and Japan, and have relocated in the industrial states in South, Southeast, and Southwest Asia; China; South America; and some in North Africa and in South Africa. Most industries of the postindustrial nations are high-tech oriented and are supported by specialty industries. Heavy industrial needs of these nations are imported competitively from the world market. This situation has brought to the forefront a serious realization that the postindustrial infrastructures in the year 2020 lack the capacity to support a national industrial surge program were it needed.

The new economic status and positions of prestige and power for the industrial states have fostered a general rise of nationalism worldwide that has affected U.S. international political influence adversely. It also has resulted in the expulsion of U.S. forces from U.S. overseas bases and port facilities and in a repossession of the land, despite any previous long-term political or military agreements. This has prompted the USSR to pursue economic and friendship ties with many of these nations.

By 2020, the growth of the U.S. population and its cities, especially those contiguous to and within the vicinity of military bases and installations, has confounded the withdrawal and restationing of U. S. forces within CONUS during the past decade or so. Environmental issues of pollution and waning resources, for example, along with demographic factors (e.g., an aging population, ethnic redistribution) and a general change of attitude and values of the U.S. citizens toward war and international involvement, are inhibiting military stationing and reducing investments in installations.

**APPENDIX B**  
**BRAVO 2020:**  
**U.S. WORLD PEACEKEEPER**  
**A MINISCENARIO**

The world economy in 2020 is brisk and highly competitive. The United States, Canada, Europe, and Japan, the leading markets of the 20th century in heavy industrial products, automobiles, and other manufactured products, are now the world leaders of high-tech products, services, information, and knowledge programs and systems. Former 20th century industrial states along with newly industrialized countries (NIC) are supplying the world with heavy industrial products and most other high-demand manufactured consumer products that were formerly produced by the nations named above. Most nations of the world, except for the very poorest, are achieving a new economic prosperity that is expanding their horizons, while altering their political and social infrastructures. Since the turn of the century, new economic and security agreements, many ad hoc, have been replacing eroding 20th century treaties and agreements.

The highly competitive world economy, along with a broad transfer of technology, has generated an increased frequency of trade wars and political and economic power competitions. Notwithstanding, most of the industrial states are trading off a new growth of nationalism for economic development and investment as a solution to financial and unemployment problems. This has strengthened U.S. international political and economic influence and has preserved U.S. military presence overseas. To most nations, the United States is the colossus of the world.

By 2020, the achievements of science and the advances of high technology in the postindustrial states have offset the economic loss of heavy industries and, coupled with specialty



industries, their infrastructures are capable of supporting an industrial surge for contingencies should crises arise.

National pride within the United States is high, as is the economy, and although social investment remains the foremost national budget expenditure, it is followed by a sizeable defense budget. Both the current Congress and the Administration as well as the general populace support extensive military programs. In general, U.S. community infrastructures (economies, demographics, resources, attitudes and values, etc.) underpin military stationing requirements and investments in installations. The enactment of a universal public service (UPS) program, which includes the military, not only bolsters the general economy, but also answers national unemployment problems and aids in melding the nation. Other areas of high national interest are education, science and technology, and space programs.

Most nations of the world, except the very poorest, have been highly armed by the new arms merchants of the industrial states. The number of states with nuclear weapons and delivery systems in their arsenals is 40 percent more than those known to have existed in 1995. Despite some strategic nuclear arms reductions by the United States, the USSR, and the USDR, early in the new century—the result of negotiations stemming from arms control meetings in the late 1980s between the United States and the former Soviet Union—U.S. and Soviet strategic nuclear capabilities remain high.

The Union of Sovereign Republics (USR), dissatisfied to remain an industrial state while the United States is an advanced postindustrial, has embarked on an ambitious plan of internal economic development encompassing its entire nation. The USR is now becoming more adventuresome militarily than it had been in 2005 and is beginning to support client states. It has, however, permitted economic fusion of many East European states with the European Community. Even so, the USR sector remains highly capable of waging war if provoked.

**APPENDIX C**  
**CHARLIE 2020:**  
**NEONATIONALISM WORLD**  
**A MINISCENARIO**

Nations of the world by 2020 have increasingly become more nationalistic, despite an increasing number of nations adopting free-market economies and representative forms of government (mostly parliamentary). These conditions have evolved over the past several decades from a gradual transformation of many formerly Third World countries that had been modernizing their societies with the aid of the American government and its private enterprises. Their international status has been raised from that of Third World nations to that of modern industrial nations.

Believing that the influx of technology and Western people's ideas was changing their societies, altering their cultural values, and obscuring their national identities, many of these newly industrial countries have sought refuge in a revival of nationalism. This has occurred despite unprecedented national economic growth and a higher standard of living for their people over the past two decades. These countries have nationalized all industries, expelled all foreigners, civilian and military, and have reclaimed the real estate of all U.S. military bases and port facilities. This rise of nationalism worldwide has suppressed U. S. opportunities for international political and economic influence.

The United States, the foremost postindustrial nation of the world, over the past several years politically has advocated maintaining a strong military defense. Its investments in technologically advanced military systems, especially those using the fourth dimension of outer space, have surpassed any previous military investments of the past three decades. These new systems have reduced the military requirement for massive land forces and placed an increasing emphasis and

demand for technology- and space-oriented counter strategies of land, sea, and air warfare. These advances in the conduct of war have been essential since in the last century heavy industries, including arms manufacturers, from the most advanced nations have relocated in other newly industrial countries.

Postindustrial infrastructures, along with specialty industries, lack the capacity to support a national industrial surge in the event of war or serious crises. Complicating this for the United States, local U.S. community infrastructures (economies, politics, demographics, resources, etc.) are inhibiting military stationing capabilities and, through political action and more drastic measures, are reducing investments in installations. Military strategists and analysts, however, have devised force structures and end strengths compatible with security needs and societal characteristics without losing sight of military missions. The military, however, must find alternative training sites or new means to train warfighters and their supporting forces.

All except the very poorest of nations have been armed by the arms merchants during the latter years of the 20th century and the early years of the new century. The number of nations with nuclear weapons and delivery systems in their arsenals has increased two-thirds over those known to have them in the 1990s. Most nations have elected to maintain a military force since they are experiencing economic growth and want to protect it. Many of these nations, however, are unable to cope with the challenges of a highly competitive world economy and are unable to devise the economic strategies needed to survive.

The Union of Sovereign Republics (USR) is bent on the industrial modernization of its entire nation. Despite moderate and incremental bilateral strategic nuclear arms reductions with the United States, stemming from U.S.-Soviet arms control meetings in the late 1980s, the USR retains a formidable warfighting capability, yet poses less threat to the European Community. The USR investments in national economic and social development, however, have reduced its

**inclination to support any client states and have curtailed its adventuresome interests.**

## **APPENDIX D DELTA 2020: MUTED MULTIPOLAR WORLD A MINISCENARIO**

Over the past decade or so, U.S. communities increasingly have rejected the presence of military bases and installations contiguous to, or within 50 miles of, major cities. East-west and north-south patterns of urban sprawl throughout the nation form vast megalopolises that are encircling military bases and installations.

Many U.S. communities vehemently oppose any increased investments in military installations made to accommodate strange and new weapon systems that might pollute their environment and consume their resources. Some states have enacted environmental protection legislation that is so stringent that many installations within those states have been forced to close. Recently, organized groups of citizens, condoned by state governments, have blocked the addition to, and creation of, installations for new military systems, troops, and training programs that they believe would increase the risk to their community as a target of enemy attack in the event of war. Most U.S. communities are economically viable and have little need for the economic support provided by military bases. Politically, most communities, local, state, and federal, are represented by a population that is an older age and approaching 40 percent blacks, Hispanics, and Asians. The political, economic, and social influence of this near majority on U.S. national and international affairs is substantial. This impact, also, affects the U.S. society in general but is especially reflected in the U.S. national political leadership who advocate comprehensive national social welfare programs and investments. These federal programs are followed by investments in education, space, science and technology, and defense programs.

The United States is the leading postindustrial nation of the world. A very large percentage of Americans are employed in the services, information, and knowledge sectors of the U.S. economy. Heavy U.S. industries, such as steel and chemicals, as well as most manufacturers of automobiles, appliances, and building supplies, have relocated in foreign nations from which the United States imports such needs. Specialty industries, such as plastics and high-technology industries, support a flourishing U.S. economy. A comparable situation exists in most of the other postindustrial nations, i.e., Canada, Europe, Australia, and Japan. Most strategic analysts believe that the postindustrial infrastructures, along with their specialty industries, lack the capacity to support national mobilization plans in the event of a major war or crisis.

Worldwide, over the past decade, many nations have traded off nationalism, that had been growing since the turn of the century, for economic security and development. This has strengthened U.S. international political, economic, and military influence and has preserved U.S. military presence, bases and installations overseas. With this arrangement, these nations not only receive financial assistance from the United States but they also receive information services and training, and most importantly, a security umbrella.

Most nations of the world, except the very poorest, are heavily armed with conventional weapons. Others, additionally, are armed with more modern high-tech weapons systems. The number of nations with nuclear weapons and delivery systems is about 40 percent greater since 1995. The Union of Sovereign Republics (USR), beset with constant economic setbacks, is bent on national economic catch-up throughout its vast territory to enable it to achieve postindustrial status and compete with the United States and its neighbors, the Union of Social Democratic Republics (USDR) and the European Community (EC). Although the USR military is less adventuresome militarily, its warfighting capabilities remain formidable and continue to be a threat to the free world.

# **A GUIDE TO ESTIMATIVE SEMANTICS\***

## ***NOMINAL AND ORDINAL SCALE FOR DESCRIBING FORECASTS***

<b>NOMINAL</b>	<b>ORDINAL (%)</b>
Sure Chance, Certain, In All Likelihood	100
Very Good Chance, Almost Certain, Very High Likelihood	90 - 95
Good Chance, Fairly Certain, Most Likely, Good Likelihood	75 - 85
Better than Even Chance, Very Likely, Fair Likelihood	60 - 70
Even Chance, Likely, A Likelihood	45 - 55
Less than Even Chance, Less than Likely	30 - 40
Small Chance, Hardly Likely, Little Likelihood	15 - 25
Poor Chance, Unlikely, Very Little Likelihood, Probable	5 - 10
Slight Chance, Possible, Improbable	4 - <1
No Chance, Not Likely, No Likelihood, Impossible	0

---

\* Adapted from Sherman Kent, *Intelligence Analyst*

## ABOUT THE AUTHOR

CHARLES W. TAYLOR, a faculty member of the U.S. Army War College, is a strategic futurist with the Strategic Studies Institute and occupies the General Douglas MacArthur Academic Chair of Research. His futures research extends over 25 years and includes major contributions in the form of narrative long-range strategic forecasts as well as in methods and designs of forecasts for studies requested by the Deputy Chief of Staff for Operations and Plans, Department of the Army. He is known internationally for his strategic forecasts and for his contributions of methods and techniques to the field of forecasting. He is the author of a number of futures studies including *The Technical Report to Forecast 90; A Concept of A Future Force; The Relationship of Forecasting to Long-Range Planning; The Pilot Delphi Project* (strategic issues to the year 2030); *A World 2010: A Decline of Superpower Influence; Alternative World Scenarios for Strategic Planning; Creating Strategic Visions; A World 2010: A New Order of Nations*; and others. Mr. Taylor is the originator of the *Panel Consensus Technique*, an internationally recognized contribution to participative decisionmaking, problem solving, and forecasting. He is a member of the American Academy of Political and Social Sciences, World Future Society, Population Reference Bureau, Association of Electronic Defense, Fellow of the Inter-University Seminar on Armed Forces and Society, Military Operations Research Society, and The Planning Forum.

•U.S. GOVERNMENT PRINTING OFFICE:1994-504-111/00017



**U.S. ARMY WAR COLLEGE**

**Major General William A. Stofft  
Commandant**

\*\*\*\*\*

**STRATEGIC STUDIES INSTITUTE**

**Director  
Colonel John W. Mountcastle**

**Director of Research  
Dr. Earl H. Tilford, Jr.**

**Editor  
Mrs. Marianne P. Cowling**

\*\*\*\*\*

**Composition  
Mrs. Mary Jane Semple**